

Small Form Factor Committee Specification of

Revision 1.2
February 24, 1994
Status: Submitted

THIS IS NOT A FINAL DRAFT

ATA Packet Interface for CD-ROMs SFF-8020

Member Companies Supporting This Specification:

Adaptec	NEC Technologies
Apple	OAK Technologies
Cirrus Logic	Panasonic
Compaq	Philips
Dell	Quantum
ENDL	Seagate
IBM	Silicon Systems
Intel	Sony Corporation
Maxtor	Wearns Technology
Microsoft	Western Digital
Molex	

Member Companies Voting Against This Specification:

Point of Contact: I. Dal Allan
Chairman SFF Committee
ENDL
14426 Black Walnut Court
Saratoga, CA 95070
Ph: (408) 867-6630
Fax: (408) 867-2115
E-Mail: 250-1752@mcimail.com

Technical Editors: Tom Hanan
Western Digital Corporation
8105 Irvine Center Drive
Irvine Calif. 92718
Ph: (714) 932-7472
Fax: (714) 932-7796
E-Mail: hanan_t@a1.wdc.com

Devon Worrell
Western Digital Corporation
8105 Irvine Center Drive
Irvine Calif 92718
Ph: (714) 932-7042
Fax: (714) 932-7796
E-Mail: worrell@dt.wdc.com

Table of Contents

1.0 Introduction 1

1.1 Abstract. 1

1.2 Secretariat 1

1.3 Summary of SFF Principals 3

1.4 SFF Membership and Fees 4

1.5 Scope 5

1.6 Audience 5

1.7 Normative References 5

1.8 Prerequisites and Related Documents 6

1.9 Layout of the Document 6

1.10 Patents 7

2.0 General. 9

2.1 Overview 9

2.2 Feature Summary. 9

3.0 Conventions 11

3.1 Document Conventions 11

3.2 Signal Conventions. 11

3.3 Definitions 11

3.3.1 Absolute F Field 11

3.3.2 Absolute M Field 11

3.3.3 Absolute S Field 11

3.3.4 ATA (AT Attachment) 12

3.3.5 BCD 12

3.3.6 Block 12

3.3.7 Blocks Per Sector. 12

3.3.8 Command Packet (CP) 12

3.3.9 CD-DA 12

3.3.10 CD-ROM 12

3.3.11 CD-ROM Control Field 12

3.3.12 CD-ROM Data Mode. 12

3.3.13 CHS (Cylinder-Head-Sector). 13

3.3.14 CIRC 13

3.3.15 Data Block 13

3.3.16 DMA (Direct Memory Access). 13

3.3.17 Field 13

3.3.18 Frame 13

3.3.19 Hold Track State 13

3.3.20 Index 13

3.3.21 Invalid 13

3.3.22 LBA (Logical Block Address) 13

3.3.23 Logical Block. 14

3.3.24 Lead-in Area 14

3.3.25 Lead-out Area 14

3.3.26 L-EC 14

3.3.27 LUN 14

3.3.28 Mandatory 14

3.3.29 MSF Address 14

3.3.30 One 14

3.3.31 Optional. 14

3.3.32 Output Port 14

3.3.33 Page. 15

3.3.34 Pause Area 15

Table of Contents

3.3.35 PIO (Programmed Input/Output) 15

3.3.36 Post-gap Area 15

3.3.37 Pre-gap Area 15

3.3.38 Relative F Field 15

3.3.39 Relative M Field 15

3.3.40 Relative S Field 15

3.3.41 SAM 15

3.3.42 Reserved 15

3.3.43 Sector 15

3.3.44 Status 16

3.3.45 Sub-channel 16

3.3.46 TOC 16

3.3.47 Track 16

3.3.48 Track Relative Logical Address 16

3.3.49 Transition Area 16

3.3.50 VU (Vendor Unique) 16

3.3.51 Zero 16

3.4 Symbols and Abbreviations 16

4.0 ATAPI Overview 17

4.1 ATA Signal Utilization 17

4.2 ATA Command Utilization 17

4.3 ATA Compatibility 17

4.4 Packet Types 17

4.5 How SCSI is Used by ATAPI 19

4.5.1 Differences from the SCSI Standard 19

4.5.2 Redundant Command Functionality (Task File vs. Packet) 20

4.5.2.1 Door Lock and Door Unlock vs. Prevent / Allow Medium Removal 20

4.5.2.2 ATAPI Identify Drive vs. Inquiry 20

4.5.2.3 Initialize Drive Parameters and Set Features vs. Mode Sense and Mode Select 20

4.5.2.4 Recalibrate vs. Rezero 20

5.0 ATAPI Protocol 21

5.1 Initialization 21

5.2 PACKET Command 21

5.3 Status Register Utilization for Packet Commands 22

5.4 Byte Count Register (Cylinder Low/High) Usage for Packet Commands 22

5.5 Sector Count (ATAPI Interrupt Reason) Register Usage for Packet Commands 23

5.6 Overlapped Command Operation 23

5.7 Flow of Packet Command, PIO Data In to Host 24

5.8 Flow of Packet Command with PIO Data Out from the Host 26

5.9 Flow of DMA Data Commands 28

5.10 Flow of Non-data Commands 28

5.11 Timing of Packet Command 29

5.12 Timing of Data and Status Transfer 30

5.13 Control Signal Timing Requirements and Relationships 31

5.14 BIOS and ATAPI Driver Compatibility 32

5.14.1 Reset Master/Slave Diagnostics Sequence 32

5.14.2 SRST Initialization Sequence 32

5.14.3 Special Handling of ATA Read and Identify Drive Commands 32

5.14.4 ATAPI aware BIOS and Driver Considerations 33

5.14.5 Default Timing 33

6.0 ATAPI Transport Mechanism 35

6.1 Reset Conditions 35

Table of Contents

	6.1.1	Power On or Hardware Reset	35
	6.2	ATAPI Soft Reset Command and Protocol	36
	6.3	ATAPI Implementation of ATA SRST	37
	6.4	Physical Connection	38
	6.5	Register Mapping	39
	6.6	ATAPI Register Map (Packet Command)	39
7.0		CD-ROM Model	43
	7.1	New Capabilities Since the SCSI-2 Standardization	43
	7.2	CD-ROM Media Organization	43
	7.3	CD-ROM Physical Data Format	47
	7.3.1	Frame Format for Audio	47
	7.3.2	Sector Format for Data	47
	7.3.3	Sub-channel Information Formats	48
	7.4	CD Audio Error Reporting	49
	7.5	CD-ROM Ready Condition/Not Ready Condition	49
	7.5.1	Packet Command Not Ready Status Utilization	50
	7.6	CD-ROM Address Reporting Formats (MSF bit)	50
	7.7	Error Reporting	51
8.0		CD-ROM ATA (Task File) Commands	53
	8.1	ATA (Task File) Command Implementation Requirements	53
	8.1.1	ATAPI Soft Reset	54
	8.1.2	Check Power Mode	54
	8.1.3	Execute Drive Diagnostics	54
	8.1.4	Idle Immediate	54
	8.1.5	Nop	54
	8.1.6	Packet Command	56
	8.1.7	ATAPI Identify Device	56
	8.1.7.1	General Configuration Word (0)	57
	8.1.7.2	Serial Number (Words 10 - 19)	58
	8.1.7.3	Buffer Type (Word 20)	58
	8.1.7.4	Buffer Size (Word 21)	58
	8.1.7.5	Firmware Revision (Words 23-26)	58
	8.1.7.6	Model Number (Words 27 - 46)	58
	8.1.7.7	Capabilities Word (Word 49)	58
	8.1.7.8	PIO Data Transfer Cycle Timing (Word 51)	59
	8.1.7.9	DMA Data Transfer Cycle Timing (Word 52)	59
	8.1.7.10	Field Validity (Word 53)	59
	8.1.7.11	Single Word DMA Transfer (Word 62)	59
	8.1.7.12	Multi Word DMA Transfer (Word 63)	59
	8.1.7.13	Enhanced PIO Mode (Word 64)	59
	8.1.7.14	Minimum Multi-word DMA Transfer Cycle Time per Word (Word 65)	60
	8.1.7.15	Manufacturer's Recommended Multi-word DMA Transfer Cycle Time (Word 66)	60
	8.1.7.16	Minimum PIO Transfer Cycle Time Without Flow Control (Word 67)	60
	8.1.7.17	Minimum PIO Transfer Cycle Time with IORDY Flow Control (Word 68)	60
	8.1.8	Set Features	61
	8.1.8.1	Set Transfer Mode (03h)	62
	8.1.8.2	Disable Reverting to Power On Defaults (66h)	62
	8.1.8.3	Enable Reverting to Power On Defaults (CCh)	62
	8.1.8.4	Disable Shared Interrupts (DDh)	62
	8.1.8.5	Enable Shared Interrupts (5Dh)	62
	8.1.9	Sleep	62

Table of Contents

8.1.10	Standby Immediate	63
9.0	CD-ROM Packet Commands	65
9.1	Packet Command Implementation Requirements	65
9.1.1	Reserved	65
9.1.2	Operation Code Types	65
9.2	ATAPI Command Packet Description	66
9.2.1	Operation Code	67
9.2.2	Logical Block Address	67
9.2.3	Transfer Length	67
9.2.4	Parameter List Length	67
9.2.5	Allocation Length	67
9.3	Status	67
9.4	Immediate Command Processing Considerations	68
9.5	Command Processing Considerations and Exception Conditions	68
9.5.1	Parameter Rounding	68
9.6	Unit Attention Condition	68
9.7	Commands and Parameters	69
9.8	ATAPI Packet Commands for CD-ROM Devices	70
9.8.1	AUDIO SCAN Command	71
9.8.2	INQUIRY Command	75
9.8.2.1	Standard INQUIRY Data	75
9.8.2.2	Using the INQUIRY Command	76
9.8.2.3	Vital Product Data	77
9.8.2.4	Vital Product Data Parameters	77
9.8.2.4.1	ASCII Implemented Operating Definition Page	78
9.8.2.4.2	ASCII Information Page	79
9.8.2.4.3	Supported Vital Product Data Pages	80
9.8.2.4.4	Unit Serial Number Page	80
9.8.3	MODE SELECT Command	83
9.8.4	MODE SENSE Command	85
9.8.4.1	Current Values	86
9.8.4.2	Changeable Values	86
9.8.4.3	Default Values	86
9.8.4.4	Saved Values	86
9.8.4.5	Initial Responses	86
9.8.5	Mode Select/Sense Parameters	88
9.8.5.1	CD-ROM Audio Control Parameters Page	90
9.8.5.2	CD-ROM Device Parameters Page	94
9.8.5.3	Read Error Recovery Parameters Page	95
9.8.5.4	CD-ROM Capabilities and Mechanical Status Page	99
9.8.6	PAUSE/RESUME Command	103
9.8.7	PLAY AUDIO (10) Command	105
9.8.7.1	Play Audio with Overlapped Packet Commands	106
9.8.8	PLAY AUDIO (12) Command	108
9.8.9	PLAY AUDIO MSF Command	109
9.8.10	PLAY AUDIO TRACK RELATIVE (10) Command	111
9.8.11	PLAY AUDIO TRACK RELATIVE (12) Command	113
9.8.12	PREVENT/ALLOW MEDIUM REMOVAL Command	115
9.8.13	READ (10) Command	117
9.8.14	READ (12) Command	119
9.8.15	READ CD-ROM CAPACITY Command	121
9.8.16	READ CD Command	123

	9.8.16.1	Description of Sub-channels R-W130
	9.8.17	READ CD MSF Command133
	9.8.18	READ HEADER Command135
	9.8.19	READ SUB-CHANNEL Command137
	9.8.19.1	CD-ROM Current Position Data Format138
	9.8.19.2	Media Catalogue Number Data Format141
	9.8.19.3	Track International Standard Recording Code Data Format142
	9.8.19.4	Caching of Sub-Channel Data144
	9.8.20	READ TOC Command145
	9.8.20.1	Sub-channel Q TOC information149
	9.8.20.2	Example Read TOC Operations151
	9.8.21	REQUEST SENSE Command153
	9.8.21.1	Sense-key Specific155
	9.8.21.2	Deferred Errors156
	9.8.21.3	Sense-key and Sense Code Definitions157
	9.8.21.4	Using the REQUEST SENSE Command157
	9.8.22	REZERO UNIT Command161
	9.8.23	SEEK Command163
	9.8.24	SET CD-ROM SPEED Command165
	9.8.25	STOP PLAY / SCAN CD-ROM Command167
	9.8.26	START/STOP UNIT Command169
	9.8.27	TEST UNIT READY Command171
	9.8.27.1	Using the TEST UNIT READY Command171
10.0		Physical Interface173
	10.1	CD-ROM Digital Audio Connector (Optional)173
	10.2	CD-ROM Analog Audio Connector (Optional)173
	10.3	Device Configuration Jumper (Optional)174
	10.4	Host IDE Interface Connector174
	10.5	Power Connector174
	A.1	Vendor Identification176
	B.1	ATAPI XA Packet Commands for CD-ROM Devices179
	B.1.1	PLAY CD-ROM XA Command179
	B.1.2	SEND CD-ROM XA DATA (12) Command181
	C.1	Connectors / Jumpers183

Preliminary Draft
for Review Only

Intentionally Left Blank

List Of Tables

Table 1 - Layout of the Document 6

Table 2 - Command and Status Usage for ATAPI Devices (Generic) 18

Table 3 - Byte Count Register Usage 22

Table 4 - Preferred Drive Connection 38

Table 5 - I/O Port Functions/Selection Addresses (Compatibility Model) 39

Table 6 - Word Mapping of Task File Registers 40

Table 7 - Example Mixed Mode CD-ROM Disc Layout 44

Table 8 - Not Ready Error Reporting (by Command). 50

Table 9 - MSF Address Format 50

Table 10 - Error Conditions and Sense Keys 51

Table 11 - ATA Command and Status Usage for ATAPI CD-ROM Devices 53

Table 12 - Identify Drive, Fields Supported by CD-ROM 56

Table 13 - Identify Drive Data - General Configuration (Word 0) 57

Table 14 - Identify Drive Data - Capabilities Word (49) 58

Table 15 - Contents of the Feature Register for Set Features Command 61

Table 16 - Set Feature Register Definitions 61

Table 17 - Feature Number Description for Set Feature Command 62

Table 18 - Operation Code Types. 65

Table 19 - Typical Command Packet for Most Commands 66

Table 20 - Typical Command Packet for Some Extended Commands 66

Table 21 - Operation Code 67

Table 22 - Packet Commands Supported by CD-ROM Drives 70

Table 23 - AUDIO SCAN Command 71

Table 24 - Scan Starting Address in Logical Block Format 72

Table 25 - Scan Starting Address in AMIN, ASEC and AFRAME Format 72

Table 26 - Scan Starting Address in Track Number (TNO) Format 72

Table 27 - Recommended Sense Key, ASC and ASCQ for Audio Scan Command Errors 73

Table 28 - INQUIRY Command 75

Table 29 - INQUIRY Data Format 76

Table 30 - Peripheral Device Types 76

Table 31 - Vital Product Data Page Codes 78

Table 32 - ASCII Implemented Operating Definition 78

Table 33 - ASCII Information Page. 79

Table 34 - Page Code 0: Supported VPD Pages 80

Table 35 - Unit Serial Number Page 80

Table 36 - Recommended Sense Key, ASC and ASCQ for Inquiry Command Errors. 81

Table 37 - Mode Select Command 83

Table 38 - Recommended Sense Key, ASC and ASCQ for Mode Select Command Errors 84

Table 39 - Mode Sense command 85

Table 40 - Page Control Field. 85

Table 41 - Recommended Sense Key, ASC and ASCQ for Mode Sense Command Errors 87

Table 42 - Mode Parameter List 88

Table 43 - Mode Page Codes for CD-ROM 88

Table 44 - Mode Page Format 88

Table 45 - Mode Parameter Header. 89

Table 46 - CD-ROM Medium Type Codes 89

Table 47 - CD-ROM Audio Control Mode Page Format 90

Table 48 - CDDA Output Port Channel Selection Codes. 91

Table 49 - Attenuation Levels for Audio 92

Table 50 - CD-ROM Parameters Page Format 94

Table 51 - Inactivity Time Multiplier Values. 94

Table 52 - Read Error Recovery Parameters Page Format 95

List Of Tables

Table 53 - Error Recovery Bit Settings 96

Table 54 - CD-ROM Error Recovery Descriptions 96

Table 55 - CD-ROM Capabilities and Mechanical Status Page Format 99

Table 56 - Example Data Rates 101

Table 57 - PAUSE/RESUME Command 103

Table 58 - Recommended Sense Key, ASC and ASCQ for Pause/Resume Command Errors 103

Table 59 - PLAY AUDIO Command 105

Table 60 - Recommended Sense Key, ASC and ASCQ for Play Audio Command Errors 106

Table 61 - Commands That Will Stop a Play Operation 107

Table 62 - Commands That Will Not Stop a Play Operation 107

Table 63 - PLAY AUDIO (12) Command 108

Table 64 - Recommended Sense Key, ASC and ASCQ for Play Audio (12) Command Errors 108

Table 65 - PLAY AUDIO MSF Command 109

Table 66 - Recommended Sense Key, ASC and ASCQ for Play Audio MSF Command Errors 110

Table 67 - PLAY AUDIO TRACK RELATIVE (10) Command 111

Table 68 - Recommended Sense Key, ASC and ASCQ for Play Track Relative (10) Command Errors 112

Table 69 - PLAY AUDIO TRACK RELATIVE (12) Command 113

Table 70 - Recommended Sense Key, ASC & ASCQ for Play Track Relative (12) Command Errors 113

Table 71 - PREVENT ALLOW MEDIUM REMOVAL Command 115

Table 72 - Actions for Lock / Unlock / Eject 116

Table 73 - Recommended Sense Key, ASC and ASCQ for Prevent/Allow Command Errors 116

Table 74 - READ (10) Command 117

Table 75 - Recommended Sense Key, ASC and ASCQ for READ (10) Command Errors 118

Table 76 - READ (12) Command 119

Table 77 - Recommended Sense Key, ASC and ASCQ for READ (12) Command Errors 119

Table 78 - READ CD-ROM CAPACITY Command 121

Table 79 - READ CAPACITY DATA 121

Table 80 - Recommended Sense Key, ASC and ASCQ for Read Capacity Command Errors 122

Table 81 - READ CD Command 123

Table 82 - READ-CD, Expected Sector Type Field Definition 124

Table 83 - READ CD, Header Code Field Definition 124

Table 84 - READ CD, Error Flag Field Definition 125

Table 85 - READ CD, Sub-channel Data Selection Field Definition 125

Table 86 - Number of Bytes Returned Based on Data Selection Field 126

Table 87 - Recommended Sense Key, ASC and ASCQ for Read CD Command Errors 127

Table 88 - CD-DA (Digital Audio) Data Block Format 127

Table 89 - R-W Raw 131

Table 90 - R-W De-Interleaved & Error Corrected 131

Table 91 - Sub-channel R-W, Allowed Mode/Item Combinations 132

Table 92 - READ CD MSF Command 133

Table 93 - Recommended Sense Key, ASC and ASCQ for Read CD MSF Command Errors 133

Table 94 - READ HEADER Command 135

Table 95 - READ HEADER Data Format 135

Table 96 - CD-ROM Data Mode Codes 136

Table 97 - Recommended Sense Key, ASC and ASCQ for Read Header Command Errors 136

Table 98 - READ SUB-CHANNEL Command 137

Table 99 -)Sub-channel Data Format Header 138

Table 100 - Sub-channel Data Format Codes 138

Table 101 - CD-ROM Current Position Data Format (Format Code 01h) 138

Table 102 - Audio Status Codes 139

Table 103 - ADR Sub-channel Q Field 140

Table 104 - Sub-channel Q Control Bits 140

List Of Tables

Table 105 - Media Catalogue Number Data Format (Format Code 02h)141

Table 106 - UPC Format142

Table 107 - Track International Standard Recording Code Data Format142

Table 108 - Raw ISRC Format on the CD-ROM Disc143

Table 109 - ISRC Format of Data Returned to Host143

Table 110 - Recommended Sense Key, ASC and ASCQ for Read Sub-channel Command Errors144

Table 111 - READ TOC Command145

Table 112 - Read TOC Data Format (With Format Field = 00b)146

Table 113 - Read TOC Data Format (With Format Field = 01b)147

Table 114 - Read TOC Data Format (With Format Field = 10b)148

Table 115 - Recommended Sense Key, ASC and ASCQ for Read TOC Command Errors148

Table 116 - Lead in Area (TOC), Sub-channel Q formats149

Table 117 - Bit Definitions for the Control Field in Sub-channel Q150

Table 118 - Values for Control Field in Sub-channel Q150

Table 119 - Example Read TOC Operations151

Table 120 - Request Sense Command153

Table 121 - Request Sense Standard Data154

Table 122 - Field Pointer Bytes155

Table 123 - Field Pointer Bytes156

Table 124 - Sense Key Descriptions157

Table 125 - ASC and ASCQ Assignments158

Table 126 - Recommended Sense Key, ASC and ASCQ for Request Sense Command Errors159

Table 127 - REZERO UNIT Command161

Table 128 - Recommended Sense Key, ASC and ASCQ for SEEK Command Errors161

Table 129 - SEEK Command163

Table 130 - Recommended Sense Key, ASC and ASCQ for Seek Command Errors163

Table 131 - SET CD-ROM SPEED Command165

Table 132 - Recommended Sense Key, ASC and ASCQ for SET CD-ROM SPEED Command Errors165

Table 133 - STOP PLAY / SCAN CD-ROM Command167

Table 134 - Recommended Sense Key, ASC and ASCQ for STOP PLAY CD-ROM Command Errors167

Table 135 - START/STOP UNIT Command169

Table 136 - Start/Stop and Eject Operations169

Table 137 - Actions for Eject/Load Disc170

Table 138 - Recommended Sense Key, ASC and ASCQ for SEEK Command Errors170

Table 139 - Test Unit Ready Command171

Table 140 - Recommended Sense Key, ASC and ASCQ for MODE SELECT Command Errors171

Table 141 - Vendor Identification List175

Table 142 - PLAY CD-ROM XA (12) Command179

Table 143 - Recommended Sense Key, ASC and ASCQ for PLAY CD-ROM XA (12) Command Errors180

Table 144 - SEND CD-ROM XA DATA (12) Command181

Table 145 - Recommended Sense Key, ASC and ASCQ for SEND CD-ROM XA ADPCM DATA Command Errors182

List Of Figures

Figure 1 - Packet Command with PIO Data In to Host 25
Figure 2 - Packet Command with PIO Data Out from Host 27
Figure 3 - Timing of Command Packet Transfer. 29
Figure 4 - Timing of Data and Status Transfer. 30
Figure 5 - SRST Sequence 37
Figure 6 - ATAPI Status Register (ATA Status Register) 40
Figure 7 - ATAPI Error Register (ATA Error Register) 40
Figure 8 - ATAPI Feature Register (ATA Feature Register). 41
Figure 9 - ATAPI Byte Count Register (ATA Cylinder High/Low Register) 41
Figure 10 - ATAPI Interrupt Reason Register (ATA Sector Count Register). 42
Figure 11 - ATAPI Drive Select Register (ATA Drive / Head Select Register) 42
Figure 12 - ATAPI Device Control Register (ATA Device Control Register) 42
Figure 13 - CD-ROM Sector Formats 45
Figure 14 - ADPCM Volume MUX / Control. 93
Figure 15 - Read CD Data Stream Order 129
Figure 16 - Read CD Sub-channel, R-W (100b). 130
Figure 17 - Stop Play/Play Audio/Audio Scan/Pause/Resume Sequencing 168
Figure 18 - CD-ROM Connectors (Rear View) 173
Figure 19 - Device Configuration Jumper 174

Preliminary Draft
for Review Only

1.0 Introduction

The ATA/IDE interface has become a de facto industry standard for connection of disk drives in PC's. In the interest of simplicity and cost, the ATA/IDE interface was originally designed to support only a small subset of computer peripherals. The expanding use of multimedia, inexpensive program distribution on CD ROM, and faster and more powerful systems has created the need for enhancements to ATA. Currently, efforts are under way (Enhanced IDE, SFF-8011, SFF-8033, ATA-2) to expand ATA/IDE to provide the following enhancements:

- Support for drives larger than 528 MB.
- Support for two connectors to allow up to four drives.
- Support for CD-ROM and tape peripherals.
- Support for 11.1/16.6 Mbytes/second, I/O Channel Ready PIO data transfers
- Support for 13.3/16.6 Mbytes/second DMA data transfers

This document addresses only the CD-ROM connection issues. There is no generally accessible standard for connection of CD-ROM devices. Several "native" interfaces exist, but they are vendor-unique. There is the SCSI Interface, which along with the Microsoft MS-DOS CD-ROM Extensions provides an actual standard, but most systems do not ship with an imbedded SCSI interface. Thus, it seemed obvious to provide a simple and inexpensive CD-ROM interface by providing a superset of ATA for that purpose.

1.1 Abstract

This document defines a standard method for interfacing to a CD-ROM Drive utilizing the existing ATA host computer hardware and cabling. This specification supplements the definitions of an ATA mass storage peripheral found in the ATA document. The ATAPI and CD-ROM interfaces described in this document are compatible with existing ATA hardware without any changes or additional pins.

1.2 Secretariat

The Small Form Factor Committee is an ad hoc group formed to address disk industry needs in a prompt manner. When formed in 1990, the original goals were limited to defining de facto mechanical envelopes for disk drives so they could fit into laptop computers and other small products.

In November 1992, the SFF Committee objectives were broadened to encompass areas other than mechanical form factors for drives, which needed prompt industry action. SFF Specifications are narrow in scope, to reduce development time.

There are several projects active within the Small Form Factor Committee. At the date of printing document numbers had been assigned to the following projects. The status of Specifications is dependent on committee activities.

Spec #	Rev.	SFF Document Titles	Status	Pages
SFF-8001	1.0	44-pin ATA (AT Attachment) Pinouts for SFF Drives	FP	14
SFF-8002	2.0	68-pin ATA (AT Attachment) for SFF Drives	FP	16
SFF-8003	1.1	SCSI Pinouts for SFF Drives	P	14
SFF-8004	1.0	Small Form Factor 2.5" Drives	A	14
SFF-8005	2.3	Small Form Factor 1.8" Drives	FP	14
SFF-8006	2.0	Small Form Factor 1.3" Drives	FP	16
SFF-8007	0.1	SFF Connector Alternatives	D	14
SFF-8008	2.2	68-pin Embedded Interface for SFF Drives	P	12
SFF-8009	2.1	Unitized Connector for Cabled Drives	P	12
SFF-8010	1.0	Small Form Factor 15mm 1.8" Drives	FP	14
SFF-8011	1.1	ATA Timing Extensions for Local Bus	FP	18
SFF-8012	1.0	Power Connector Pin Dimensions	FP	10
SFF-8013	0.1	ATA Download Microcode Command	Fs	8
SFF-8014		Unitized Connector for Rack Mounted Drives	D	n/a
SFF-8015		Single Connector for Rack Mounted Drives	D	n/a
SFF-8016		Small Form Factor 10mm 2.5" Drives	C	n/a
SFF-8017	0.1	A-Cable SCSI on a 68-pin Connector	D	12
SFF-8018	0.1	ATA Low Power Modes	Fs	8
SFF-8019	0.2	Identify Drive Data for ATA Disks over 528 MB	D	10
SFF-8020	1.2	ATA Packet Interface for CD-ROMs	D	200

n/a =

No document available yet

F = Forwarded

The document has been approved by the members for forwarding to a formal standards body.

P = Published

The document has been balloted by members and is available as a published SFF Specification.

A = Approved

The document has been approved by ballot of the members and is in preparation as an SFF Specification.

tion.

D = Development

The document is under development at SFF.

E = Expired

The document has been published as an SFF Specification, and the members voted against re-publishing it when it came up for annual review.

s = submitted

The document is a proposal to the members for consideration to become an SFF Specification.

FD

A Specification in Development Forwarded to a standards committee.

FA

An Approved Specification Forwarded to a standards committee.

FP

A Published Specification Forwarded to a standards committee.

Fs

A submitted proposal Forwarded directly to a standards committee.

The SFF Committee complements the formal standards process. Some industry needs cannot be addressed by standards because of timing, or charter, or some other consideration. This is a gap the Small Form Factor Committee fills.

It is anticipated that most Specifications will be Forwarded to an accredited standards body such as EIA (Electronic Industries Association) or ASC (Accredited Standards Committee) X3T9. They may be accepted for separate standards, or incorporated into other standards activities.

The members decision to forward is based on a wide variety of factors, and a document can be forwarded at any stage in its development cycle. For example, if a proposal is under development within SFF, and a standards project begins in a similar area. The SFF members might submit the draft of the SFF Specification to the standards committee rather than operate a parallel effort.

In the case of proposals submitted to SFF which now have a status of Fs, the proposal never became an SFF project or specification. Instead the proposal was forwarded to the appropriate standards body for further consideration. A copy of the proposal submitted to SFF remains available for historical purposes, however, the contents may no longer be valid. The latest documentation for forwarded SFF specifications should be obtained from the committee the proposal was forwarded to. The best way to track standards activity is to subscribe to the document service for X3T9 subcommittees:

CBEMA X3 Secretariat: Ph: 202-737-8888
1250 Eye St. #200 Fax: 202-638-4922
Washington DC 20005

Copies of SFF Specifications are available by FaxAccess or by joining the SFF Committee as an Observer (\$300 or \$400 overseas) or Member (\$3,000).

14426 Black Walnut Ct Ph: 408-867-6630x303 Email: 250-1752@mcimail.com
Saratoga CA 95070 Fax: 408-867-2115 FaxAccess: 408-741-1600

1.3 Summary of SFF Principals

Documents created by the SFF Committee are expected to be submitted to accredited standards bodies such as EIA (Electronic Industries Association) or ASC (Accredited Standards Committee) X3T9. They may be accepted for separate standards, or incorporated into other standards activities. The principles of operation for the SFF Committee are not unlike those of an accredited standards committee. There are 3 levels of participation:

- Attending the meetings is open to all, but taking part in discussions is limited to member companies, or those invited by member companies.
- The minutes and copies of material which are discussed during meetings are distributed only to those who sign up to receive documentation.
- The individuals who represent member companies of the SFF Committee receive documentation and vote on issues that arise. Votes are not taken during meetings, only guidance on directions. All voting is by letter ballot, which ensures all members an equal opportunity to be heard.

Material presented at SFF Committee meetings becomes public domain. There are no restrictions on the open mailing of material presented at committee meetings. In order to reduce disagreements and misunderstandings, copies must be provided for all agenda items that are discussed. Copies of the material presented, or revisions if completed in time, are included in the documentation mailings.

The sites for SFF Committee meetings rotate based on which member companies volunteer to host the meetings. Meetings have typically been held on the first day of the X3T9 Working Group weeks (the third week of odd months).

1.4 SFF Membership and Fees

The funds received from the annual membership fees are placed in escrow, and are used to reimburse ENDL for the services to manage the SFF Committee.

Annual SFF Committee Membership Fee	\$ 3,000.00
Annual SFF Committee Documentation Fee	\$ 300.00
Annual Surcharge for AIR MAIL to Overseas	\$ 100.00

Funds received will be retained in escrow until earned and will be accounted for to the members of the SFF Committee.

To join SFF, fill out the form below and indicate the method of payment.

Name:	_____
Title:	_____
Company:	_____
Address:	_____ _____ _____
Phone:	_____
Fax:	_____
Email:	_____

Please register me as the company representative on the SFF Committee (\$3,000 fee includes documentation).

Check Payable to SFF Committee is Enclosed: _____

Please Invoice me: ___ PO #: _____

Signature: _____

Please register me to receive documentation on activities of the SFF Committee.

Check Payable to SFF Committee: U.S. \$ 300
(POs Not Accepted) Overseas \$ 400

Signature: _____

Fax POs to: 408 867-2115	Mail Checks to: 14426 Black Walnut Ct.
 Saratoga, CA 95070

1.5 Scope

This document is intended to be used with the ATA document. Its purpose is to highlight those areas of implementation in which the CD-ROM Interface and the ATA document differ. In addition, it indicates areas within the ATA document which are modified for operation in the CD-ROM environment. Both mandatory and optional specifications are presented.

In the event of a conflict between one of the base documents (ATA / SCSI CD-ROM) and this document, the interpretation of this document *shall* prevail *only if this document acknowledges that a conflict exists between the documents*.

This document provides a description for the ATAPI Transport Protocol (TP), ATAPI Transport Mechanism (TM) as well as a CD-ROM Command Protocol (CP).

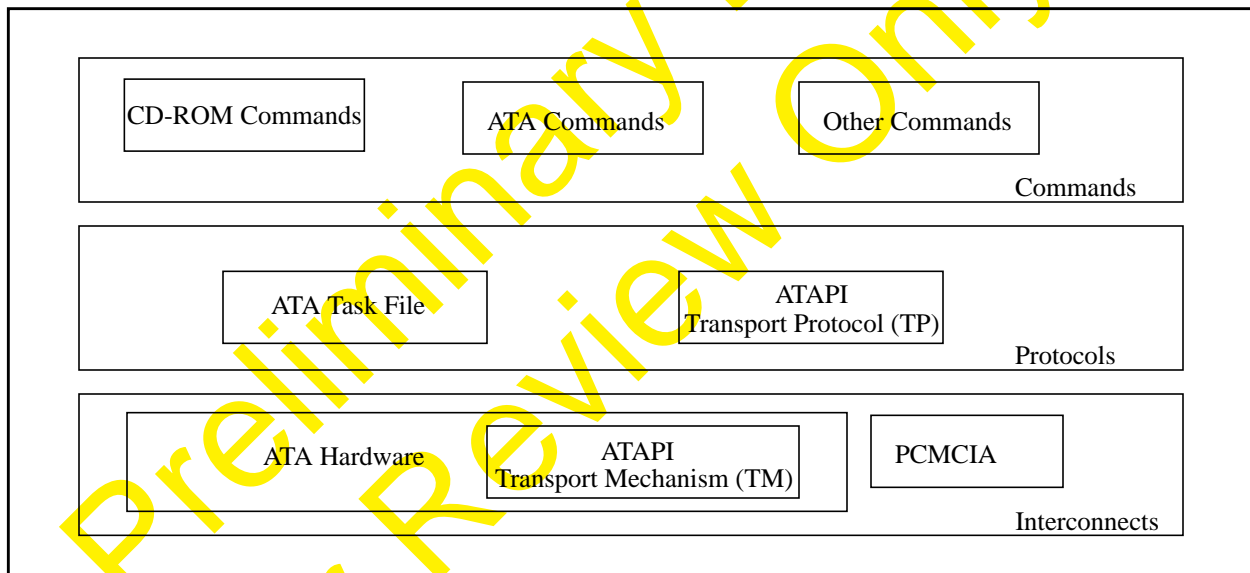

1.6 Audience

This document is intended for use by Computer System, CD-ROM Peripheral, and CD-ROM chip set vendors.

1.7 Normative References

The following standards contain provisions which, when referenced in the text of this standard, constitute provisions of this Specification. At the time of publication, the editions indicated were valid. All standards are subject to revision, and parties to agreements based on this Specification are encouraged to investigate the possibility of applying the most recent editions of the standards indicated below. Members of IEC and ISO maintain registers of currently valid International Standards.

ISO/IEC 10149:1989, Information technology - *Data Interchange on Read-only 120 mm Optical Data Disks (CD-ROM)*.

IEC 908:1987, *Compact Disk Digital Audio System*.

American National Standard ANSI X3T9.2/375R revision 10k, *Small Computer System Interface*.

American National Standard ANSI X3T9.2/791D revision 4a, April 19, 1993, *CBEMA ATA (AT Attachment)*.

1.8 Prerequisites and Related Documents

The reader is expected to have a basic understanding of the AT hardware and software interfaces as well as the ATA Document. Specifically, the following documents are required for understanding and implementing an ATA CD-ROM because this document is based on them:

- CBEMA, ATA (AT Attachment) ANSI Draft Standard, Revision 4a, April 19, 1993, Document Number X3T9.2/791D, Computer and Business Equipment Manufacturer's Association. This is referred to as the ATA Document.
- ANSI X3T9.2/375R, Small Computer System Interface
- AT bus specification
- SFF-8011 Rev. 1.2, ATA Timing Extensions for Local Bus Attachment.
- Red, Yellow, Green, Orange Books and CD-ROM XA Specification.

1.9 Layout of the Document

This document is broken into several sections:

Table 1 - Layout of the Document

Section "1.0 Introduction" on page 1	Introduction, scope, purpose etc.	SFF-8021
Section "2.0 General" on page 9	Details the current requirements, assumptions and goals.	
Section "3.0 Conventions" on page 11	Describes conventions used in the document, and a definitions of terms and signals.	
Section "4.0 ATAPI Overview" on page 17	Overview of the Packet Interface and how the "Layering" of SCSI and ATA occurs.	SFF-8022
Section "5.0 ATAPI Protocol" on page 21	Describes the actual "Protocol" used for the new Packet Command.	
Section "6.0 ATAPI Transport Mechanism" on page 35	Describes ATAPI register and hardware usage of the ATA Interface.	
section 7.0, "CD-ROM Model", on page 43	Overview and general comments on CD-ROM device functions and media formats.	SFF-8023
section 8.0, "CD-ROM ATA (Task File) Commands", on page 53	ATA Task File Command set definition for the CD-ROM peripheral type.	
Section "9.0 CD-ROM Packet Commands" on page 65	SCSI Command Subset definition for the CD-ROM peripheral type.	SFF-8024
Section "10.0 Physical Interface" on page 173	Describes the physical Host Interface, connectors and their placement.	SFF-8025
Annex "A" Vendor Identification	Provides informative reference material and describes extended features and commands which will very likely be implemented by some CD-ROM manufacturers.	SFF-8026
Annex "B" CD ROM XA Commands		SFF-8027
Annex "C" Audio Connectors		SFF-8028
Annex "D" Errata sheet for SFF-8020 rev 1.2	Identifies current editorial & technical corrections made to SFF-8020 rev 1.2.	SFF-8029

To simplify retrieval of this document via the SFF FaxAccess system, the individual sections of this document are available as individual SFF FaxAccess documents. Unless you have a plain paper fax machine with the ability to print 300 pages in a single fax, you should request the individual sections. Request SFF-8020 to receive the entire document or request any of the numbers between 8021 and 8029 to receive the individual section(s) identified in the table above.

1.10 Patents

The developers of this specification have requested that holders of patents that may be required for the implementation of the specification, disclose such patents to the publisher. However, neither the developers nor the publisher have undertaken a patent search in order to identify which, if any, patents apply to this specification.

No position is taken with respect to the validity of any claim or any patent rights that may have been disclosed. Details of submitted statements may be obtained from the publisher concerning any statement of patents and willingness to grant a license under these rights on reasonable and nondiscriminatory terms and conditions to applicants desiring to obtain such a license.

Preliminary Draft
for Review Only

**Preliminary Draft
for Review Only**

Intentionally Left Blank

2.0 General

2.1 Overview

The primary objective of this Standard is to provide an inexpensive CD-ROM interface. The existing ATA does not provide an adequate command structure to support CD-ROM devices. Although the inclusion of a CD-ROM drive would compromise the performance of another disk on the same ATA Cable, this standard does not attempt to address the "Performance" issues.

2.2 Feature Summary

This section provides an abbreviated list of the perceived requirements upon which the development of this specification was based.

- **Do not break any existing ATA drive connections when the CD-ROM is attached**, e.g., completely compatible with existing hardware and drivers.
- Prevent BIOS and O/S recognition of ATAPI Peripherals as hard disk drives.
- Allow the ATA cable and I/O registers to support one ATA drive and one CD-ROM peripheral.
- Support for the ATA master / slave protocol.
- Support for 8-bit Task File registers and 16-bit data transfer register.
- Reset the peripheral into a known state.
- Provide a status indication of Peripheral Ready to accept commands.
- Provide capability for sending CDB like (Command Packet Bytes) to the peripheral.
- Support for command packets of at least 12 bytes in length.
- Capability to indicate to the Host computer when Command Packet can be transferred.
- Capability to Interrupt the Host computer when data can be transferred.
- Capability to Interrupt the Host computer when command complete.
- Send & Receive Data bytes using PIO.
- Provide a simple DMA capability.
- Capable of transferring variable length data packets. (Drive indicates to Host amount to transfer.)
- Send Status of command operation (Error / Done / Data Ready...) to the host computer.
- Enable and disable interrupts from the peripheral.
- Detect when a peripheral is interrupting (Which & Why.)
- Detect when an ATAPI peripheral is attached to the ATA Cable.
- Support for both primary and secondary ATA addressing / cable.
- Support for SFF-8011 ATA Timing Extensions for Local Bus.
- Support for the CD-DA, CD-XA, Multi Session and Hybrid (Photo CD) formats.
- Support for multiple speed drives.
- Support multiple block sizes (i.e. 2048, 2052, 2056, 2324, 2332, 2336, 2340 & 2352)

**Preliminary Draft
for Review Only**

Intentionally Left Blank

3.0 Conventions

3.1 Document Conventions

Certain words and terms used in this document have specific meaning beyond the normal English meaning. These words and terms are defined either in this section or in the text where they first appear. Names of signals, commands, statuses, and sense keys are in all uppercase (e.g. REQUEST SENSE). Lower case is used for words having the normal English meaning.

Fields containing only one bit are usually referred to as the <name> bit instead of the <name> field. Numbers that are not immediately followed by a lower case b or h are decimal (0xnn for Hexadecimal, where nn refers to two hexadecimal digits 0-9, A-F.)

3.2 Signal Conventions

Signal names are shown in all upper case letters. Signals can be asserted (active, true) in either a high (more positive voltage) or low (less positive voltage) state. A dash character (-) at the beginning or end of a signal name indicates it is asserted at the low level (active low). No dash or a plus character (+) at the beginning or end of a signal name indicates it is asserted high (active high). An asserted signal may be driven high or low by an active circuit, or it may be allowed to be pulled to the correct state by the bias circuitry.

Control signals that are asserted for one function when high and asserted for another function when low are named with the asserted high function name followed by a slash character (/), and the asserted low function name followed with a dash (-) e.g. BITENA/BITCLR- enables a bit when high and clears a bit when low. All signals are TTL-compatible unless otherwise noted. "Negated" means that the signal is driven by an active circuit to the state opposite to the asserted state (inactive, or false) or may be simply released (in which case the bias circuitry pulls it inactive, or false) at the option of the implementor.

Control signals that may be used for two mutually exclusive functions are identified with their two names separated by a colon e.g. SPSYNC:CSEL can be used for either the Spindle Sync or the Cable Select functions.

3.3 Definitions

3.3.1 Absolute F Field

Absolute F field is the least significant part of the absolute physical address from the beginning of the media. It is written on CD-ROM media in binary-coded decimal notation. The value ranges from 00 to 74.

3.3.2 Absolute M Field

Absolute M field is the most significant part of the absolute physical address from the beginning of the media. It is written on CD-ROM media in binary-coded decimal notation. The value ranges from 00 to 99.

3.3.3 Absolute S Field

Absolute S field is the intermediate significant part of the absolute physical address from the beginning of the media. It is written on CD-ROM media in binary-coded decimal notation. The value ranges from 00 to 59.

3.3.4 ATA (AT Attachment)

ATA defines a compatible register set and a 40-pin connector and its associated signals.

3.3.5 BCD

Binary coded decimal: The number system used on the physical CD-ROM and CD-DA media. Numbers that use this notation have the 'bcd' suffix attached. A byte has two 4-bit values, each of which can have a value from 0 to 9. The maximum value is 99bcd (99 decimal).

Example: 00 01 02 03... 08 09 10 11... 19 20 21... 98 99.

3.3.6 Block

The term "block" refers to the data in one logical block; the number of bytes in a block is defined by the logical block length in the mode block descriptor.

3.3.7 Blocks Per Sector

"Blocks per sector" is the number of logical blocks read from each CD-ROM physical sector. The value depends on the logical block length as defined in the mode block descriptor. The value for blocks per sector is:

1 if the logical block length is 2048, 8 if the logical block length is 256 bytes.
(Assuming a density code of 1 -- 2048 bytes of data per sector.)

3.3.8 Command Packet (CP)

"Command Packet" is the structure used to communicate commands from a host computer to an ATAPI device.

3.3.9 CD-DA

Compact Disc-Digital Audio (CD-DA) is the standardized medium for recording digital/audio information. The 'Red Book' defines CD-DA media.

3.3.10 CD-ROM

Compact Disc - Read Only Memory (CD-ROM) is the standardized medium for recording digitized audio and digital data. CD-ROM is used to describe media with digital data rather than discs that encode audio only. The ISO/IEC 10149 standard defines CD-ROM media.

3.3.11 CD-ROM Control Field

The CD-ROM Control Field is a 4-bit field in the Q sub-channel data indicating the type of information encoded on the current track. It indicates audio versus data and the type of audio encoding, etc. The control field is also found in the table of contents entries.

3.3.12 CD-ROM Data Mode

A byte in the header of CD-ROM data sectors. This indicates if data is present and if layered error correction information is present.

3.3.13 CHS (Cylinder-Head-Sector)

This is an ATA term defining the addressing mode of the drive as being by physical address. This form of addressing is not used by ATAPI Devices.

3.3.14 CIRC

Cross Interleaved Reed-Solomon Code (CIRC) is the error detection and correction technique used within small frames of audio or data. The CIRC bytes are present in all CD-ROM data modes. The error correction procedure which uses the CIRC bytes is referred to as the CIRC based algorithm. In most CD-ROM drives, this function is implemented in hardware.

3.3.15 Data Block

This term describes a data transfer, and is typically a single sector, except when declared otherwise by use of the Set Multiple command.

3.3.16 DMA (Direct Memory Access)

DMA is a means of data transfer between peripheral and host memory without processor intervention.

3.3.17 Field

A field is a group of one or more contiguous bits.

3.3.18 Frame

A frame is a physical sector on CD-ROM media or the F field unit of a MSF CD-ROM address. The term frame is also used in the CD-ROM model to describe the amount of data received between synchronization patterns. Ninety-eight frames make a sector. This sort of frame is referred to as a 'small frame' when the meaning is not clear from the context.

3.3.19 Hold Track State

When a CD-ROM device enters the hold track state the optical pick-up is maintained at an approximately constant position on the media. This allows a paused operation to be resumed without latency due to seeking. However, rotational latency may be incurred.

3.3.20 Index

An index is a subdivision of a CD-ROM track. A track can have from 1 to 99 index numbers. Index numbers within a track are sequential, starting with 1.

3.3.21 Invalid

Invalid refers to an illegal (reserved) or unsupported field or code value.

3.3.22 LBA (Logical Block Address)

The LBA defines the addressing mode of the drive by the linear mapping of sectors from 0 to n.

3.3.23 Logical Block

A Logical Block is a unit of data supplied or requested by a host computer.

3.3.24 Lead-in Area

The Lead-in Area is the area on a CD-ROM disc preceding track one. The main channel in the lead-in area contains audio or data null information. This area is coded as track zero but is not addressable via the ATA CD-ROM command set. The Q sub-channel in this area is coded with the table of contents information.

3.3.25 Lead-out Area

The Lead-out Area is the area on a CD-ROM disc beyond the last information track. The main channel in the lead-out area contains audio or data null information. This area is coded as track AA bcd but is not addressable via the ATA CD-ROM command set. The READ CD-ROM CAPACITY data is the first logical block address of this area minus one.

3.3.26 L-EC

Layered Error Correction (L-EC) is the error correction technique used with CD-ROM (data mode one) sectors. In such sectors, 276 bytes of the auxiliary data field contain L-EC bytes. The algorithm that uses these bytes to perform error correction is often implemented in the drive firmware.

3.3.27 LUN

Logical Unit Number.

3.3.28 Mandatory

“Mandatory” indicates that a referenced item is required to claim compliance with this standard.

3.3.29 MSF Address

The MSF Address is the physical address written on CD-ROM discs. It is expressed as a sector count relative to either the beginning of the medium (absolute) or to the beginning of the current track (relative). As defined by the CD-DA and CD-ROM standards, each F field unit is one physical sector; each S field unit is 75 F field units; each M field unit is 60 S field units. Valid contents of F fields are binary values from 0 through 74. Valid contents of S fields are binary values from 0 through 59. Valid contents of M fields are binary values from 0 through 99.

3.3.30 One

“One” represents a true signal value or a true condition of a variable.

3.3.31 Optional

“Optional” describes features which are not required by the standard. However, if any feature defined by the standard is implemented, it *shall* be done in the same way as defined by the standard. Describing a feature as optional in the text is done to assist the reader. If there is a conflict between text and tables on a feature described as optional, the table *shall* be accepted as being correct.

3.3.32 Output Port

The Output Port is a means for connecting the audio signal being played to equipment outside the CD-ROM device.

3.3.33 Page

Several commands use regular parameter structures that are referred to as pages. These pages are identified with a value known as a page code.

3.3.34 Pause Area

A “pause area” is a transition area at the beginning or end of an audio track encoded with audio silence. This transition area is required where the audio track immediately precedes a data track.

3.3.35 PIO (Programmed Input/Output)

PIO is a means of data transfer that requires the use of the host processor.

3.3.36 Post-gap Area

Post-gap Area is a transition area at the end of a data track encoded with null information. This transition area is required where the data track immediately precedes an audio track.

3.3.37 Pre-gap Area

Pre-gap Area is a transition area at the beginning of a data track encoded with null information. This transition area is required where the data track immediately follows an audio track.

3.3.38 Relative F Field

The sub-division of the S field part of the relative physical address from the beginning of the current track. One physical sector. Written on CD-ROM medium in binary coded decimal notation. The value is from 00bcd to 74bcd.

3.3.39 Relative M Field

Relative M Field is the most significant part of the relative physical address from the beginning of the current track. It is written on CD-ROM media in binary-coded decimal notation. The value is from 00bcd to 99bcd.

3.3.40 Relative S Field

Relative S Field is the intermediate significant part of the relative physical address from the beginning of the current track. It is written on CD-ROM medium in binary-coded decimal notation. The value is from 00bcd to 59bcd.

3.3.41 SAM

SCSI Architectural Model.

3.3.42 Reserved

Reserved bits, fields, bytes, and code values are set aside for future standardization. Their use and interpretation may be specified by future extensions to this or other standards. A reserved bit, field, or byte *shall* be set to zero, or in accordance with a future extension to this standard. The recipient *shall* not check reserved fields.

3.3.43 Sector

“Sector” refers to the data contained by one frame time. (On CD-DA medium with two channels of audio this is 1/75th

of a second). In the CD-ROM standard document the term block is used for this unit. There may be more than one logical block per sector. Similarly, a single logical block may map to multiple sectors.

3.3.44 Status

Status is one byte of information sent from the ATA CD-ROM to the host computer upon completion of each command.

3.3.45 Sub-channel

CD-ROM and CD-DA media have a main channel and a sub-channel. The sub-channel area has eight parts called P, Q, R, S, T, U, V, and W. The Q-sub-channel contains information useful to the controller and drive, such as the control field and MSF addresses. The data rate of each sub-channel (P, Q, etc.) is 1/192nd of that of the main channel.

3.3.46 TOC

The table of contents has information on the type of disc and the starting address of the tracks. This information is encoded in the Q sub-channel.

3.3.47 Track

A track is a sub-division of the CD-ROM media. A disc has from one to ninety-nine tracks. The data within a track is always of the same type. A track can be either CD-ROM or CD-Audio. A disc can start at any track number.

3.3.48 Track Relative Logical Address

Track Relative Logical Address is an offset from the beginning of the recorded information on a track expressed in units of the logical block length. The value is used to address logical blocks relative to the beginning of a track using the relative MSF address encoded in the CD-ROM Q sub-channel.

3.3.49 Transition Area

Sectors at the beginning or end of tracks that are coded with null information are called transition areas. Where required by the media standards, these areas have minimum lengths of 1 s or 2 s. The maximum lengths are not specified. Transition areas at the beginning of a track are encoded with index zero. Addresses within transition areas may not be read.

3.3.50 VU (Vendor Unique)

The term, VU, is used to describe bits, bytes, fields, code values and features which are not described in this standard, and may be used in a way that varies between vendors.

3.3.51 Zero

Zero is a false signal value or a false condition of a variable.

3.4 Symbols and Abbreviations

AWG American Wire Gauge
LSB Least significant bit
LUN Logical unit number
MSB Most significant bit

4.0 ATAPI Overview

The purpose of the ATAPI is to provide a more extensible and general purpose interface than the ATA Task file.

Although the attachment of a CD-ROM on the ATAPI Interface will utilize the ATA Host Hardware and Task File, the logical interface will differ slightly and will need to support additional capabilities. The Mass Storage devices connected to the ATA make use of eight registers (Task File) that contain the command and all parameters needed for operation. However, eight registers is not enough to pass all the needed information for commanding other peripheral types. To remedy this, the ATAPI Device will receive its commands through the use of a Packet mode, in addition to the normal ATA protocol. The Packet Command will complement the existing ATA commands. The ATAPI Device *shall* support all of the ATA specified protocol, including the Reset Master/Slave Diagnostic Sequence, Diagnostic Command, and Command Abort for unsupported Commands. The ATAPI Device *shall* also support both the Master and Slave modes of operation.

4.1 ATA Signal Utilization

ATAPI Devices will utilize the same signals and timing from the ATA Standard and Extensions.

4.2 ATA Command Utilization

The ATA Task File concept does not contain enough bytes to support some of the CD-ROM command structures, so a new command called "Packet Command" has been added to allow a Packet to be sent to the Device. The Packet will be transferred by writing multiple times to the Data Register. No random access to the register file in the Peripheral can be done. This technique reduces the number of register addresses needed, but not the actual space needed. Although all the commands for the CD-ROM Device could be sent via this packet mode, it is believed that some of the existing ATA commands and the full ATA command protocol must be provided for the existing drivers to operate correctly. The CD-ROM Device will therefore support some existing ATA commands in addition to the new "Packet command", so that there will be minimal changes to the existing drivers. This minimal set of ATA commands is different than the minimum as defined in the ATA standard, but should be sufficient for normal operation.

4.3 ATA Compatibility

There are several backward compatibility issues with the existing ATA commands, and therefore the ATAPI CD-ROM Device will respond to the existing ATA Reset Master/Slave Diagnostic Sequence, but not the Identify Drive or Read commands. This will allow the BIOS and older drivers to ignore the CD-ROM Device and not confuse CD-ROM data with normal ATA Drive format data. All unsupported ATA commands *shall* be Aborted, and not executed. As with aborted commands in ATA, an interrupt will be generated to signal the completion with an "aborted" error status.

4.4 Packet Types

To allow for generic packet transfer and the connection of SCSI like peripherals, there *shall* exist a minimum set of information that is exchanged. This information *shall* generically support the following:

- Command Packet (Always padded to number of bytes identified in byte 0 of the identify drive data. 00 = 12 bytes, 01 = 16 bytes)
- Command Parameter Data (e.g. Write Data etc.)
- Command Response Data (e.g. Read Data etc.)
- Status. The Status will not take the form of a packet of information. The status will be presented using the ATAPI Status Register (redefinitions of the ATA Status Register).

Table 2 - Command and Status Usage for ATAPI Devices (Generic)

Command	Used	Code	Error Register						Status Register				
			BBK	UNC	IDNF	ABRT	TKONF	AMNF	DRDY	DWF	DSC	CORR	ERR
Acknowledge media change	N	DB				V							V
Boot - post-boot	N	DC				V							V
Boot - pre-boot	N	DD				V							V
Check power mode	M	E5				V			V	V	V		V
Door lock	O	DE			V	V			V				V
Door unlock	O	DF				V							V
Execute drive diags	M	90	Special Drive Diagnostic Errors										V
Format track	O ¹	50		V		V			V	V	V		V
Identify drive	N	EC				V							V
Idle	O	E3				V			V	V	V		V
Idle immediate	M	E1				V			V	V	V		V
Initialize drive parms	N ²	91				V							V
NOP	M	00				V							V
ATAPI Pkt. Command	M	A0	Contains Packet Command Status						V			V	V
ATAPI Identify Device	M	A1				V			V	V	V		V
ATAPI Soft Reset	M	08											
Read buffer	N	E4				V							V
Read DMA (w/retry)	N	C8				V							V
Read DMA (wo/retry)	N	C9				V							V
Read long (w/retry)	N ²	22				V							V
Read long (wo/retry)	N ²	23				V							V
Read multiple	N	C4				V							V
Read sector(s) (w/retry)	N ²	20				V							V
Read sector(s) (wo/retry)	N ²	21				V							V
Read verify sector(s) (w/retry)	N ²	40				V							V
Read verify sector(s) (wo/retry)	N ²	41				V							V
Recalibrate	O ¹	1x				V	V		V	V	V		V
Seek	N ¹	7x				V							V
Set features	M	EF				V			V	V	V		V
Set multiple mode	N	C6				V			V	V	V		V
Sleep	M	E6				V			V	V	V		V
Standby	O	E2				V			V	V	V		V
Standby immediate	M	E0				V			V	V	V		V
Write buffer	N	E8				V							V
Write DMA (w/retry)	N	CA				V							V
Write DMA (wo/retry)	N	CB				V							V
Write long (w/retry)	N ²	32				V							V

Table 2 - Command and Status Usage for ATAPI Devices (Generic)

Command	Used	Code	Error Register						Status Register				
			BBK	UNC	IDNF	ABRT	TKONF	AMNF	DRDY	DWF	DSC	CORR	ERR
Write long (wo/retry)	N ²	33				V							V
Write multiple	N	C5				V							V
Write same	N	E9				V							V
Write sector(s) (w/retry)	N ²	30				V							V
Write sector(s) (wo/retry)	N ²	31				V							V
Write verify	N	3C				V							V
Invalid command code						V			V	V	V		V

V = valid on this command
M = Mandatory and *shall* be supported by CD-ROM ATAPI Devices, as specified by the ATA Standard
O = Optional for use by an ATAPI Device
N = Not supported by ATAPI Devices (*shall* be Aborted by the ATAPI Device)
Shaded = Commands are utilized by the ATAPI Devices

1. Although this command is Optional for ATAPI the ATA Standard specifies it as Mandatory.
2. This command is specified as Mandatory for ATA, but *shall* NOT be supported by ATAPI Devices.

4.5 How SCSI is Used by ATAPI

Although the ATAPI Device will utilize many of the actual packet definitions from the SCSI standard, it will NOT use most other features of the normal SCSI Protocol. Thus there are no Phases, no Messages, no sharable bus, (only one Host Computer) and no SCSI Hardware. For those who are familiar with the current SCSI-3 effort, this Standard will not conform with that Packetized Standard, due mostly to limitations of ATAPI.

4.5.1 Differences from the SCSI Standard

Some of the major differences from the SCSI Standard:

- Status will use the ATAPI description, rather than a Data Byte passed at the end of the command.
- ATAPI Device is slave during operation rather than the master view of a SCSI Peripheral.
- No messages are supported.
- No disconnect/reconnect or any of the SCSI Pointers.
- No linking or queuing of commands.
- All CD-ROM Command Packets (CP) are 12 bytes in length, rather than the 6, 8, 10 or 12-byte packets of the SCSI Standard; however, 16-byte ATAPI Command Packets are defined for SAM compatibility for future Devices. The size of the Command Packet required by a Device is defined in word 0 of the ATAPI Identify Device command, allowing Host System Device Drivers to determine the size of the Command Packets before issuing an ATAPI Command Packet.
- No allegiance conditions are used.

This standard will make use of many of the Standard SCSI Command Block definitions and Commands, but some of the commands that would normally be supported by a SCSI Device will not be supported for various reasons. These commands are:

- Reserve and release; as there is only one Host allowed, this is not needed.
- Send and receive diagnostics; the ATA EXECUTE DRIVE DIAGS command replaces these com-

mands.

- Change definitions; as there is no SCSI, this command is nonsensical.
- Copy / Copy and Verify; no shared bus so this command can't be implemented.
- Compare; no shared bus, so this command can't be implemented.
- Read and Write Buffer; simplification.
- Log Sense and Select; simplification.
- Search Data; simplification.
- Verify; simplification.

4.5.2 Redundant Command Functionality (Task File vs. Packet)

The SCSI Standard has provided some commands that the ATA Standard also provides. It is the intent of this standard to allow all the functionality to exist, by utilizing only Command Packets. This will allow existing SCSI like drivers to continue to issue packets for all operation, and have some lower level driver convert them to the ATAPI protocol. Unfortunately there are existing low level drivers that would like to continue to use some non data transfer ATA Task File commands. As such both these "Task File" and "Packet" commands will be supported.

4.5.2.1 Door Lock and Door Unlock vs. Prevent / Allow Medium Removal

There is a need to support a removable Device protocol that allows the Device to send a request to the Host to unlock and/ or Eject the media. There is already an existing methodology that provides this capability in ATA. The device requested eject is performed by setting the MCR bit in the Error Register and issuing an Error status to the Host (ERR bit in the Status Register.) The Host would then issue an ACKNOWLEDGE MEDIA CHANGE command to indicate that it will perform the Unlock / Eject sequence. The SCSI PREVENT/ALLOW MEDIUM REMOVAL command only allows the host to "Prevent" the user from removing the media and not to signal when the user needs to remove the media. As such both the ATA and Packet (ATAPI) versions of the commands will be supported. When the ATA Door Lock is used, only the MCR bit will be presented to the host, which can then poll for this condition. When the Packet commands are used the MCR / Acknowledge Media Change sequence will not be used. The Door Lock / Unlock and Acknowledge Media Change commands are optional, but if the MCR bit is set by the device, they *shall* be supported.

4.5.2.2 ATAPI Identify Drive vs. Inquiry

The ATAPI IDENTIFY DRIVE command has information that the low level drivers use to perform ATA interface hardware configuration. Information in the Identify Drive *shall* continue to look exactly as the ATA Identify Drive does for compatibility reasons. As the information in the Inquiry Command cannot be returned by the ATAPI Identify Drive Command, the Inquiry Command will be supported for use by higher level drivers.

4.5.2.3 Initialize Drive Parameters and Set Features vs. Mode Sense and Mode Select

The INITIALIZE DRIVE PARAMETERS command does not contain a method to provide non ATA device configuration information, and will not be used. As such the Mode Select and Mode Sense from the SCSI standard *shall* be supported. The combination of Mode Select and Set Features commands contain all the necessary functionality and is most compatible with the existing BIOSes and OS Drivers.

4.5.2.4 Recalibrate vs. Rezero.

The RECALIBRATE ATA command is being kept for compatibility reasons. Either command will perform the same function.

5.0 ATAPI Protocol

The ATAPI Device is commanded by two methods, the original ATA Commands utilizing the Task File and the new Packet Command method. For both methods, the devices using this interface *shall* be programmed by the host computer to perform commands and return status to the host at command completion. When more than one Device is daisy chained on the interface, commands are written in parallel to all peripherals, and for ATA commands except the Execute Diagnostics command, only the selected Device (DRV bit in the Drive/Head ATA Register) executes the command. On an Execute Diagnostics command addressed to Device 0, both devices *shall* execute the command, and Device 1 *shall* post its status to Device 0 via PDIAG-.

The "Protocol" for ATAPI centers around the usage of a new ATA Command called "Packet Command." All the normal ATA rules and protocol are used to issue the Packet Command, but once the command has been issued, a new set of rules applies:

1. The interpretation of the DRQ bit in the Status Register *shall* be used along with the Interrupt Reason Registers to determine the actual Interrupt Type.
2. The actual command for the Device to execute is sent as a packet via the data register, and not the Task File.
3. Command arguments are supplied by the Command Packet as well as from the Task File.
4. A Byte Count is used to determine the amount of data the Host *shall* transfer at each DRQ Interrupt.
5. The ATAPI Features Register is used to indicate when DMA will be used rather than by using different opcodes.
6. The final status is presented to the Host as a new interrupt after the last data has been transferred, rather than along with the last block of data.

These new rules (protocol) only apply from after the issuance of the Packet Command, until the Completion Status has been read by the Host. After the Completion Status has been read, the Task File Register definitions and Protocol revert to the standard ATA definition.

5.1 Initialization

The ATAPI Device will respond just as defined in the ATA Standard. The DASP and PDIAG signals will be utilized following any reset condition, except the ATAPI RESET command.

5.2 PACKET Command

The Packet Command is issued exactly as normal ATA commands, by initializing the Task File Registers, setting the Drive Selection Bit and writing the Command byte into the Command Register. With normal ATA commands a DRQ (Optional Interrupt) would be generated to indicate that the data for the command could be transferred to/from the Device. With the Packet Command, the first DRQ indicates that the Command Packet Data *shall* be written to the Device. Once the Command Packet has been sent, the command proceeds as a normal ATA command would. The Command Packet bytes *shall* always be transferred via PIO and never using DMA.

ATA Packet Commands can be issued regardless of the state of the DRDY Status Bit.

If while polling BSY the device remains in a state where it cannot accept a command for more than 5 seconds, the Host *shall* time out and reset the device.

Data transfers may be accomplished in more ways than are described by this standard, but the sequences described in this Standard *shall* be used to remain compatible with current and future ATAPI Devices.

5.3 Status Register Utilization for Packet Commands

See "6.6 ATAPI Register Map (Packet Command)" on page 39 for a description of the register definition.

5.4 Byte Count Register (Cylinder Low/High) Usage for Packet Commands

This register is used to control the number of bytes the Host *shall* transfer at each DRQ. It is only used for the command parameter data being transferred via PIO and never for DMA or Command Packet bytes.

Since the length of data that is actually transferred to and from an ATAPI Device using PIO is controlled by the Host, and since the ATAPI Device needs to be able to control the number of bytes transferred, an additional capability was needed. By using the Byte Count Register, a capability to transfer a variable number of bytes has been created. In ATAPI the Device indicates to the Host the number of bytes that *shall* be transferred on each DRQ Interrupt. Before transferring data, the Host *shall* read the 16-bit Byte Count Register, and comply with the length requested. Both the ATAPI Device and the Host will have their own byte counts and will transfer until those counts go to zero. For some commands, such as Mode Sense, the Host does not know the amount of data that will be transferred, and *shall* rely on the Byte Count supplied by the Device to transfer the correct amount of data.

When using DMA to transfer data the Byte Count Register is not used and will contain unspecified data.

A further capability of the Byte Count Register is for the Host to signal to the ATAPI Device the maximum amount of data it can take in a single PIO DRQ packet and or the preferred PIO DRQ packet size. For all commands that require data be transferred, the Host *shall* set the Byte Count Register to the desired length before issuing the Packet Command. This length *shall* be used by the ATAPI Device as the maximum size for each PIO data packet. The Device can choose to transfer PIO DRQ packets smaller than those set by the host in the Byte Count Register.

For all commands that can transfer all the data in one DRQ Interrupt, the Byte Count *shall* contain the total data length. When a Read command is being processed, the ATAPI Device may wish to send all the data that is available in its buffers on just one DRQ Interrupt, with the limitation that only 65535 bytes may be transferred at one time.

Table 3 - Byte Count Register Usage

Operation	Usage (PIO)	Usage (DMA)
Send Command Packet	Is used as a parameter to the Packet Command and is not used to control the Packet transfer.	Command Packet is always sent via Programmed I/O and not DMA.
Parameters to the Packet Command (Task File Contents)	As a parameter to any Packet Command that will transfer parameter data, the Byte Count is used by the Host to communicate the maximum / preferred amount of data to be transferred on each DRQ.	The Device can ignore the byte count, as the actual transfers are controlled via the ATAPI Device and not the Host.
Parameter Data from the Device to the Host (e.g. data from a Read, or Inquiry command)	At each DRQ the count contains the number of bytes that the Host <i>shall</i> transfer from the Device.	The ATAPI Device can transfer data whenever it wishes, and as such the Byte Count <i>shall not</i> be used.
Parameter Data from the Host to the Device (e.g. data for a Write, or Mode Select command)	At each DRQ the count contains the number of bytes that the Host <i>shall</i> transfer to the Device.	The ATAPI Device can transfer data whenever it wishes, and as such the Byte Count <i>shall not</i> be used.

If the Device requests more data be transferred than required by the command protocol, the Host *shall* pad when sending data to the Device, and dump extra data into a bit bucket when reading data from the Device.

On odd byte transfers, the only permissible time for an actual Odd Byte Count value will be on the Last DRQ, intermediate DRQs *shall* contain even byte counts.

5.5 Sector Count (ATAPI Interrupt Reason) Register Usage for Packet Commands

The Interrupt Reason Register contains an expanded definition of the ATA DRQ Status. When the DRQ is presented in the ATAPI Status Register for an ATAPI Packet Command, then the contents of this register indicate if Packet Command or User Data shall be transferred.

5.6 Overlapped Command Operation

Some of the ATAPI Commands are immediate. These commands return Completion Status immediately, with the actual execution of the command continuing. When the actual completion of the command has occurred, the Device shall set the DSC bit in the Status Register.

- Immediate Mode commands that report completion before the actual completion (Seek, Play Audio, etc.) *shall* respond in one of the following ways:
 - (1) The new command is queued; or
 - (2) The new command is executed with the previous command stopped and no error reported; or
 - (3) The new command is executed with no impact on the immediate mode command.
- ATA commands operate differently from packet commands. When a new ATA command is written to the Command Register, before a command has completed, the executing command stops execution and the new command is aborted with an Aborted Command error.
- New ATAPI packet commands received while a previous packet command is still executing shall cause both commands to be aborted with an error, "Check Condition".
- If an Immediate Mode command is executing when the device is issued an SRST the DSC bit *shall* not be cleared with the rest of the status register. Instead the functionality of the DSC bit *shall* be maintained.

5.7 Flow of Packet Command, PIO Data In to Host

This class includes commands such as Inquiry, Read etc. Execution includes the transfer of some unknown number of data bytes from the Device to the host.

1. The host Polls for BSY=0, DRQ=0 then initializes the task file by writing the required parameters to the Features, Byte Count, and Drive/Head registers.
2. The host writes the Packet Command code (A0h) to the Command Register.
3. The Device sets BSY, before the next system read of the status register, and prepares for Command Packet transfer.
4. When the Device is ready to accept the Command Packet, the Device sets CoD and clears IO, BSY prior to asserting DRQ. Some Devices will assert INTRQ following the assertion of DRQ. See section 8.1.7.1, "General Configuration Word (0)", on page 57 for command packet DRQ types and other related timing information.
5. After detecting DRQ, the host writes the 12 bytes (6 words) of Command to the Data Register.
6. The Device(1) clears DRQ (when the 12th byte is written), (2) sets BSY, (3) reads Features and Byte Count requested by the host system, (4) prepares for data transfer.
7. When data is available, the Device:(1) places the byte count of the data available into the Cylinder High and Low Registers, (2) sets IO and clears CoD, (3) sets DRQ and clears BSY, (4) sets INTRQ.
8. After detecting INTRQ, the host reads the DRQ bit in the Status Register to determine how it *shall* proceed with the command. If DRQ=0 then the device has terminated the command. If DRQ=1 then the host *shall* read the data (number of bytes specified in the Cylinder High/Low Registers) via the Data Register. In response to the Status Register being read, the Device negates INTRQ for both cases.
9. The Device clears DRQ. If transfer of more data is required, the Device also sets BSY and the above sequence is repeated from step 7.
10. When the Device is ready to present the status, the Device places the completion status into the Status Register, sets CoD, IO, DRDY and clears BSY, DRQ, prior to asserting INTRQ.
11. After detecting INTRQ & DRQ=0 the host reads the Status Register and if necessary, the Error Register for the command completion status.

The DRQ signal is used by the device to indicate when it is ready to transfer data, and is cleared after (during) the last byte of data to be transferred. This applies for both Command Packet as well as normal read/write data.

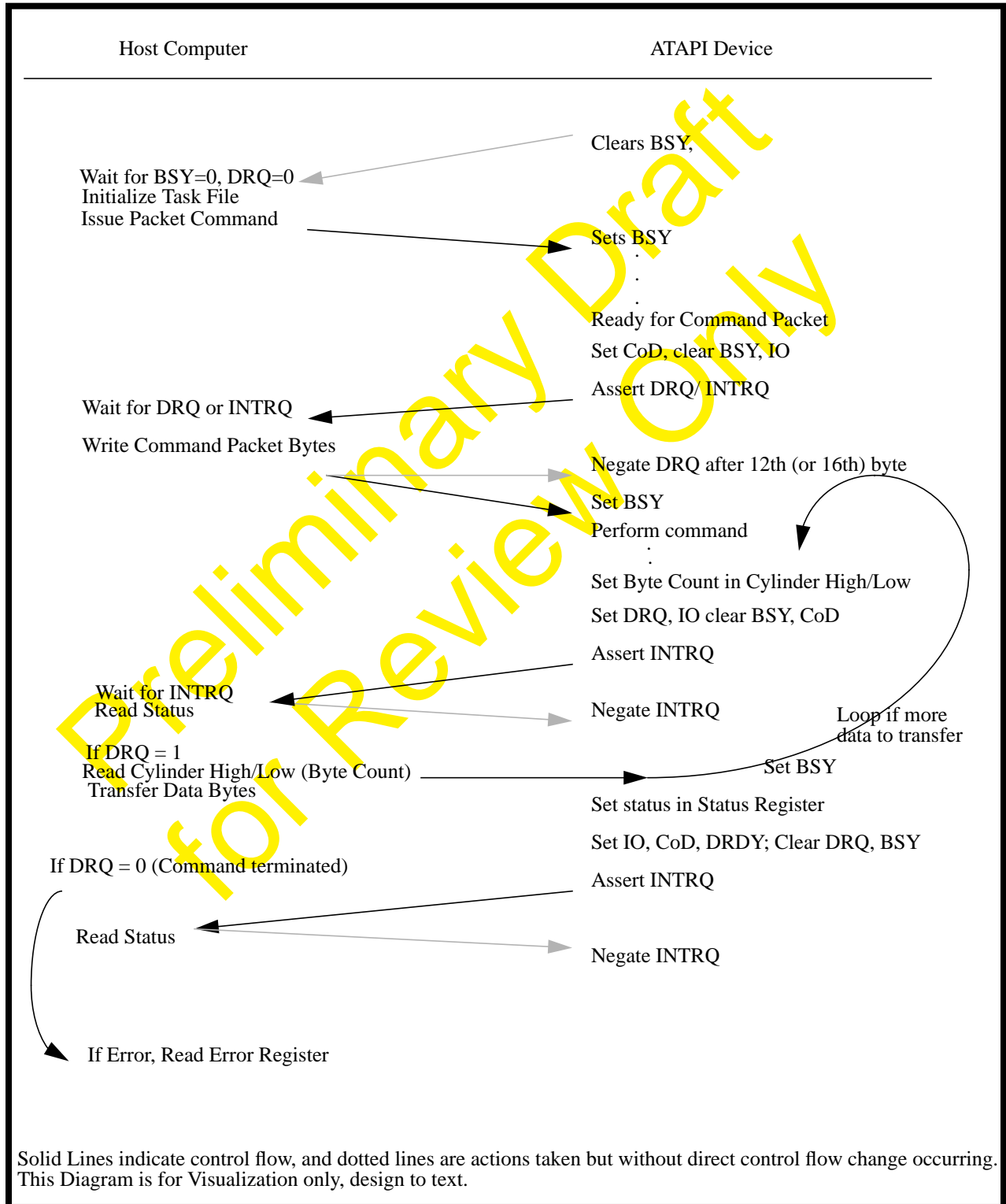

Figure 1 - Packet Command with PIO Data In to Host

5.8 Flow of Packet Command with PIO Data Out from the Host

This class includes commands such as Mode Select, Write etc. Execution includes the transfer of some known number of data bytes from the Host to the Device.

1. The host Polls for BSY=0, DRQ=0 then initializes the task file by writing the required parameters to the Features, Byte Count, and Drive/Head registers.
2. The host writes the Packet Command code (A0h) to the Command Register.
3. The Device sets BSY, before the next system read of the status register, and prepares for Command Packet transfer.
4. When the Device is ready to accept the Command Packet, the Device sets CoD and clears IO, BSY prior to asserting DRQ. Some Devices will assert INTRQ following the assertion of DRQ. See section 8.1.7.1, "General Configuration Word (0)", on page 57 for command packet DRQ types and other related timing information.
5. After detecting DRQ, the host writes the 12 bytes (6 words) of Command to the Data Register.
6. The Device(1) clears DRQ (when the 12th byte is written), (2) sets BSY, (3) reads Features and Byte Count requested by the host system, (4) prepares for data transfer.
7. When ready to transfer data, the Device:(1) sets the byte count (Cylinder High and Low Registers) to the amount of data that the Device wishes to be sent, (2) clears IO and CoD, (3) sets DRQ and clears BSY, (4) sets INTRQ. The Byte Count would normally be set to the number of bytes requested by the contents of the register at the receipt of the command, but may be any amount that the Device can accommodate in its buffers at this time.
8. After detecting INTRQ, the host reads the DRQ bit in the Status Register to determine how it shall proceed with the command. If DRQ= 0 then the device has terminated the command. If DRQ=1 then the host *shall* write the data (number of bytes specified in the Cylinder High/Low Registers) via the Data Register. In response to the Status Register being read, the Device negates INTRQ for both cases.
9. The Device clears DRQ and sets BSY. If transfer of more data is required, the above sequence is repeated from 7.
10. When the Device is ready to present the status, the Device places the completion status into the Status Register, sets CoD, IO, DRDY and clears BSY, DRQ, prior to asserting INTRQ.
11. After detecting INTRQ & DRQ=0 the host reads the Status Register and if necessary, the Error Register for the command completion status.

The DRQ signal is used by the device to indicate when it is ready to transfer data, and is cleared after (during) the last byte of data to be transferred. This applies for both Command Packet as well as normal read/write data.

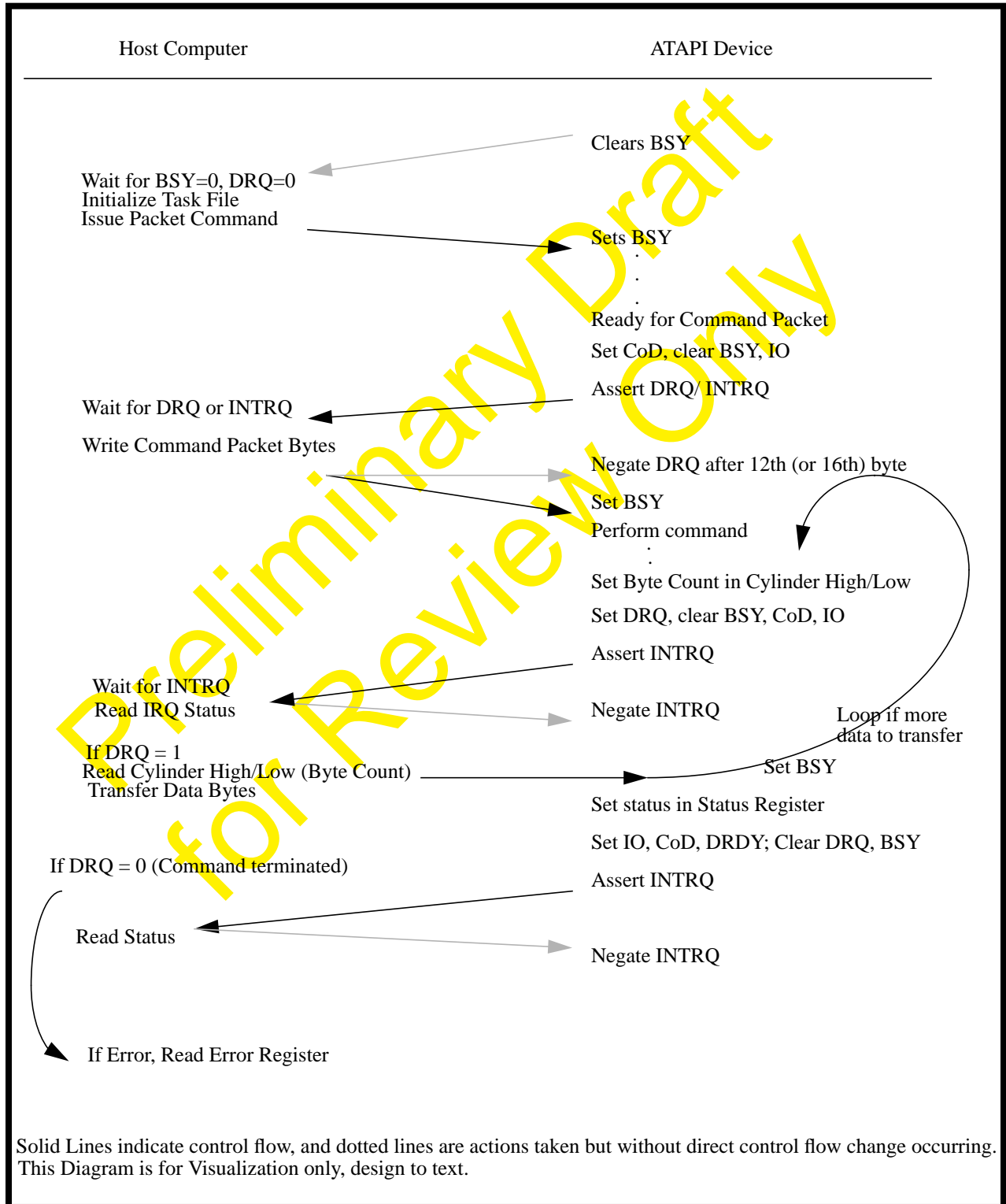

Figure 2 - Packet Command with PIO Data Out from Host

5.9 Flow of DMA Data Commands

This class includes commands such as Read, Write etc. Execution includes the transfer of some unknown number of data bytes.

1. The host Polls for BSY=0, DRQ=0 then initializes the task file by writing the required parameters to the Features, Byte Count, and Drive/Head registers. The host must also initialize the DMA engine which will service the Devices requests.
2. The host writes the Packet Command code (A0h) to the Command Register.
3. The Device sets BSY and prepares for Command Packet transfer.
4. When the Device is ready to accept the Command Packet, the Device sets CoD and clears IO, BSY prior to asserting DRQ. Some Devices will assert INTRQ following the assertion of DRQ. See section 8.1.7.1, "General Configuration Word (0)", on page 57 for command packet DRQ types and other related timing information.
5. After detecting DRQ, the host writes the 12 bytes (6 words) of Command to the Data Register.
6. The Device(1) clears DRQ (when the 12th byte is written), (2) sets BSY, (3) reads Features and Byte Count requested by the host system, (4) prepares for data transfer.
7. When ready to transfer data, the Device transfers via DMARQ/DMACK any amount that the Device can accommodate or has in its buffers at this time. This continues until all the data has been transferred.
8. When the Device is ready to present the status, the Device places the completion status into the Status Register, and sets IO, CoD, DRDY and clears BSY, DRQ, prior to asserting INTRQ.

After detecting INTRQ the host reads the Status Register for the command completion status.

5.10 Flow of Non-data Commands

This class includes commands such as Seek, etc. Execution of these commands involves no data transfer.

1. The host Polls for BSY=0, DRQ=0 then initializes the task file by writing the required parameters to the Features, Byte Count, and Drive/Head registers.
2. The host writes the Packet Command code (A0h) to the Command Register.
3. The Device sets BSY and prepares for Command Packet transfer.
4. When the Device is ready to accept the Command Packet, the Device sets CoD and clears IO, BSY prior to asserting DRQ. Some Devices will assert INTRQ following the assertion of DRQ. See section 8.1.7.1, "General Configuration Word (0)", on page 57 for command packet DRQ types and other related timing information.
5. After detecting DRQ, the host writes the 12 bytes (6 words) of Command to the Data Register.
6. The Device sets BSY and executes the command.
7. When the Device is ready to present the status, the Device places the completion status into the Status Register, and sets IO, CoD, DRDY and clears BSY, DRQ, prior to asserting INTRQ.
8. After detecting INTRQ, the host reads the Status Register for the command completion status.

5.11 Timing of Packet Command

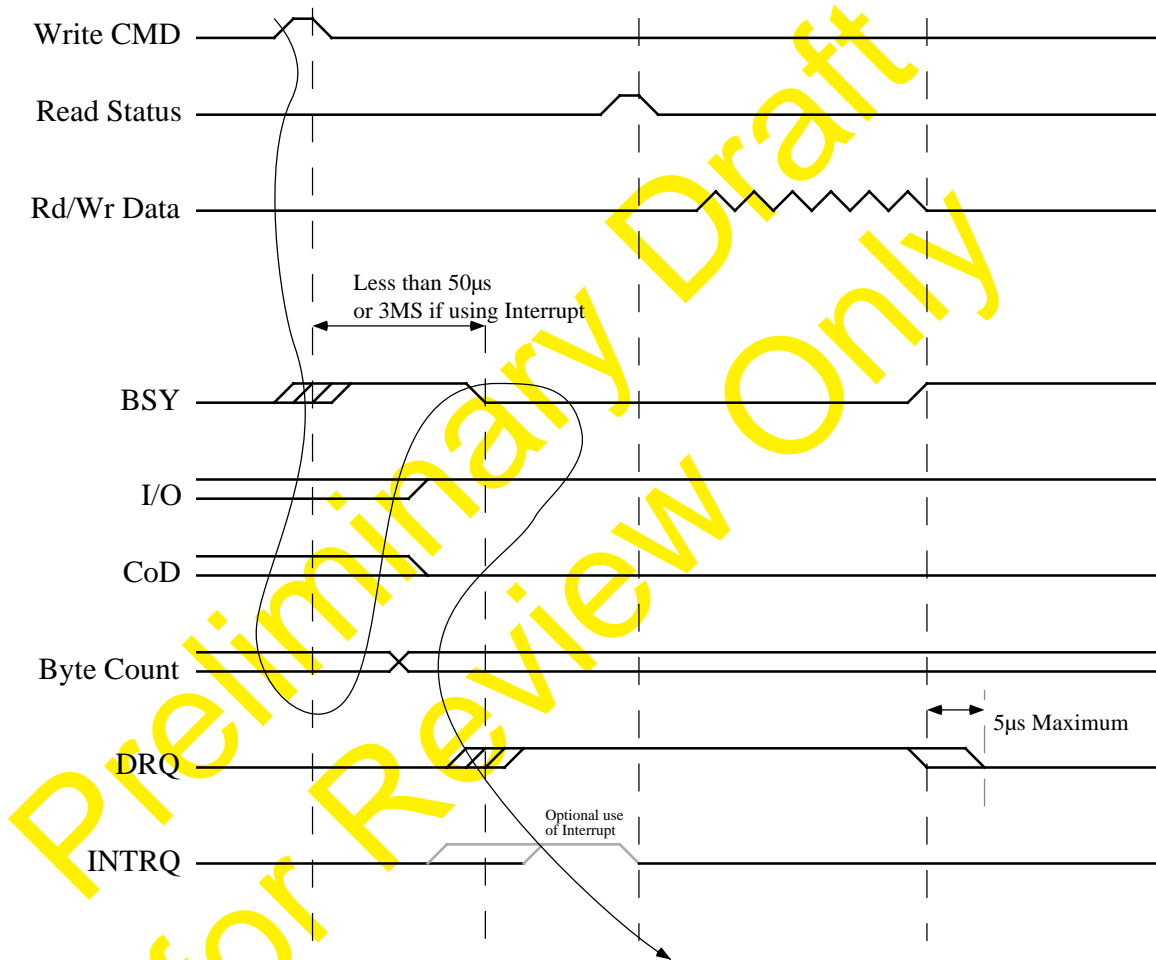

Figure 3 - Timing of Command Packet Transfer

5.12 Timing of Data and Status Transfer

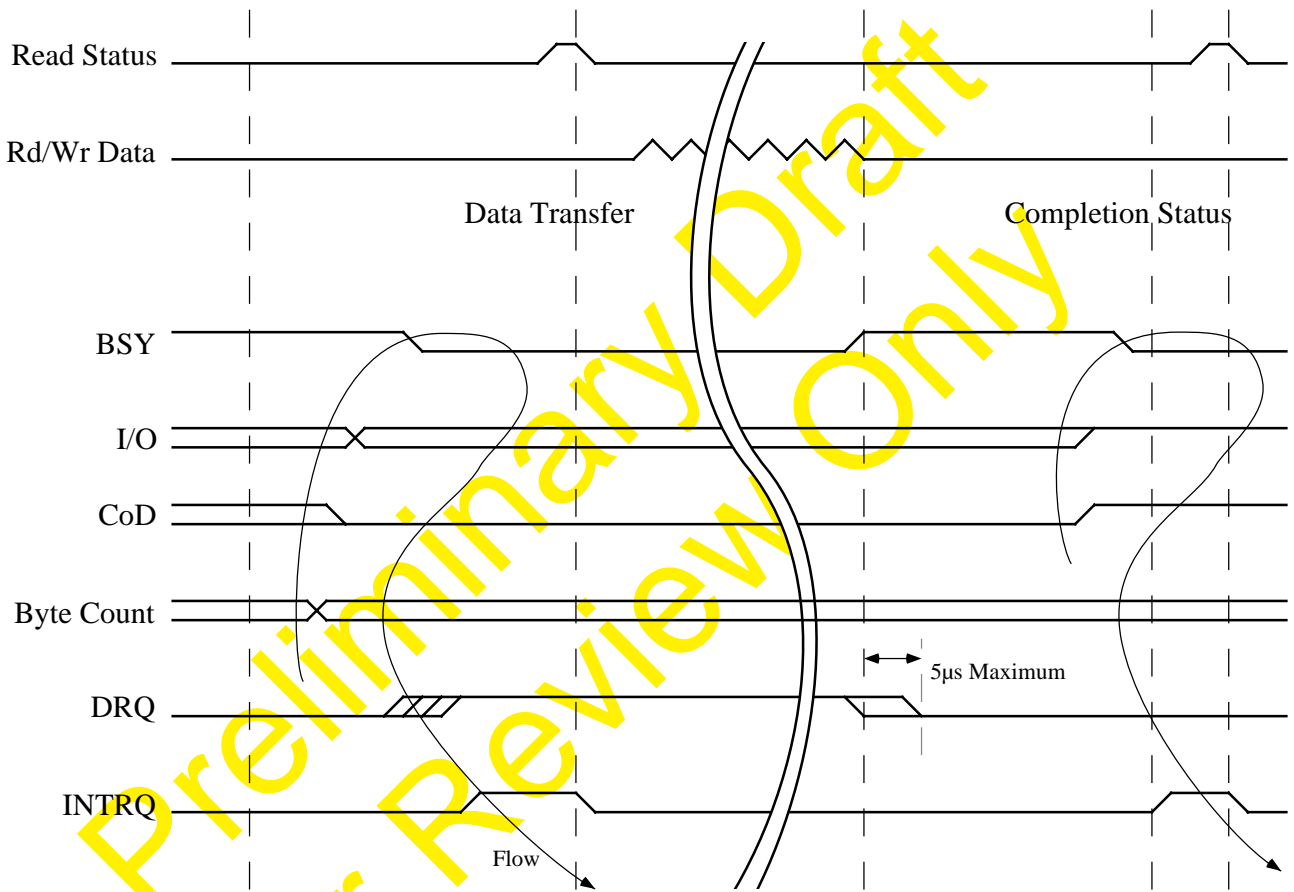

Figure 4 - Timing of Data and Status Transfer

5.13 Control Signal Timing Requirements and Relationships

The order that the signals change *shall* adhere to the following conditions:

1. Upon receiving the A0h ATAPI Packet Command the Device *shall* have BSY asserted until the next host access of the Status Register where the device can guarantee that CoD=1 and IO=0.
2. The Device *shall* not assert DRQ until CoD and IO are valid for the command or data packet to be transferred and the device is ready to perform that transfer.
3. DRQ may be set before or after BSY has been deasserted.
4. The Device *shall* clear BSY and set DRQ within the time-out specified by the CMD DRQ Type. See section 8.1.7.1, "General Configuration Word (0)", on page 57 for additional information.
5. Devices reporting CMD DRQ Type "Accelerated" *shall* de-assert DRQ within 5 μ s of the last word transferred for a command or data packet.
6. Devices reporting a CMD DRQ Type other than "Accelerated" *shall* de-assert DRQ, before asserting INTRQ, following the last word transferred for a command or data packet.

Implementer's Note: Early ATAPI Devices reporting CMD DRQ Types other than "Accelerated" may not be able to de-assert DRQ before the next INTRQ. Host systems should therefore wait until the device asserts INTRQ before testing DRQ following the transfer of the last data word in a command or data packet.

See section 8.1.7.1, "General Configuration Word (0)", on page 57 for additional DRQ and other timing related information.

5.14 BIOS and ATAPI Driver Compatibility

This section discusses the IDE features and functions that *shall* be provided by the ATA Device to allow the BIOS and driver to be content.

5.14.1 Reset Master/Slave Diagnostics Sequence

A Reset Master/Slave Diagnostics Sequence with a Good Status *shall* be provided or the BIOS will not continue. When the CD-ROM is the slave device, and it does not respond after the Reset or Diagnostic Commands, the Master Device will return an Error Condition to the Host Computer and all will die.

5.14.2 SRST Initialization Sequence

The SRST bit in the ATAPI Device Control Register (See "Figure 12 - ATAPI Device Control Register (ATA Device Control Register)" on page 42) *shall* NOT be used by the ATAPI Driver. Instead the ATAPI Device Driver *shall* reset the ATAPI Device utilizing the ATAPI Soft Reset command (see "6.2 ATAPI Soft Reset Command and Protocol" on page 36). Resetting the ATAPI Device using the ATA SRST would also reset any ATA hard drive attached, and if there are separate Drivers for an IDE and an ATAPI device, each driver would be resetting the others peripheral without the other driver being aware of the reset.

After Receipt of an ATAPI Packet Command there are several differences from the ATA Specification:

A value other than 00h or 10h in the status register prior to the receipt of the first ATAPI Command Packet from the host may cause ATAPI Devices to be incorrectly identified by pre-ATAPI host BIOS as an ATA-compatible disk drive.

Initializing the task file upon receipt of an SRST should work since only immediate commands will be executing when an ATA disk driver issues an SRST. To prevent interruption of ATAPI immediate commands which have not finished executing, the function of the DSC bit (i.e. command complete) *shall* be maintained. On a warm boot the BIOS and/or drivers may see a status of 00h or 10h, depending on whether or not an ATAPI immediate command completed at the same time the system performed the WARM BOOT.

The signature placed in the task file following an SRST *shall* remain until the ATAPI device receives its first ATAPI command, i.e., the ATAPI device will look NOT READY (DRDY=0). This will not affect the ATAPI device drivers ability to send ATAPI commands to the ATAPI device since it is not required to wait for DRDY=1. However, it will prevent ATA-compatible drivers, such as those performing power management, from sending commands to an ATAPI device until the ATAPI device has received its first ATAPI command: ATAPI Packet Command, ATAPI Identify Device, ATAPI Soft Reset.

ATAPI drivers wishing to use ATA power management commands must poll DRDY and, if it is not set, they must also look at the Cylinder registers for the ATAPI signature. If the signature is present, the ATAPI driver must issue the ATAPI device an ATAPI command, re-enabling DRDY, before it can issue an ATA Power management command. Operating systems wishing to use a common ATA power management driver must also be changed to perform this detection and recovery sequence, if they intend to power-manage ATAPI devices.

5.14.3 Special Handling of ATA Read and Identify Drive Commands

ATAPI drivers *shall* not issue SRST since it may corrupt the state of ATA IDE drives sharing the same cable. Instead, ATAPI drivers *shall* use the ATAPI Soft Reset or ATAPI PACKET RESET command to initialize an ATAPI device. Note that ATAPI commands shall not be issued to a device which has not already been identified as an ATAPI device. In order to provide ATAPI drivers with the ability to force a device to initialize its ATAPI signature (Cylinder High = EBh, Cylinder Low = 14h) without issuing an SRST, ATAPI devices *shall* abort the ATA Read and Identify Drive commands and initialize the task file with the ATAPI signature before clearing BSY.

5.14.4 ATAPI aware BIOS and Driver Considerations

Pre-ATAPI BIOS will not detect or configure ATAPI devices. Some of these BIOS are capable of configuring ATA hard disks for ATA Mode 3 IORCHDY operation. This places a special burden on ATAPI drivers to detect the presence of any ATA disk drives sharing the same port address and configure the ATAPI device for a compatible mode of operation.

Note that a special IDE port configuration driver must be provided by the IDE card manufacturer to configure the cards proprietary IDE configuration control registers. These proprietary IDE card drivers should be loaded before the ATAPI driver.

During ATAPI device detection, ATAPI device drivers or ATAPI-aware BIOS should verify that Status=00h (Not BSY, Not RDY) and that the ATAPI signature Cylinder High = EBh, Cylinder Low = 14h are present. If an ATAPI device is detected, then issue an ATAPI Identify Command to complete the ATAPI detection protocol and re-enable the task file (DRDY=1). If the device is ready to accept an ATA command, but no ATAPI signature is detected, then issue an ATA Read or Identify Drive command to the device to force the ATAPI device to initialize its signature. Then wait for BSY=0 and re-verify the presence of the ATAPI signature. If there is still no ATAPI signature present, do not configure the device.

ATAPI-aware BIOS and drivers should give special attention to managing configurations where ATAPI drivers share an IDE port address (Cable) with ATA IDE drives and their drivers. ATA IDE drivers frequently issue SRSTs to manage errors thereby causing ATAPI devices to clear DRDY as part of their SRST ATAPI signature initialization sequence. If the ATAPI driver already knows that the device it wishes to issue an ATAPI command to is an ATAPI device, then it need not take special action since issuing any of the ATAPI commands which do not require DRDY=1, will restore the ATAPI device's ability to accept ATA commands. If, however, the ATAPI driver wishes to issue an ATA command to an ATAPI device which has received an SRST from an ATA IDE driver, it should issue the ATAPI device an ATAPI Soft Reset to restore the ATAPI device's ability to accept ATA commands.

Note that "Newer" BIOS detect the presence of a Drive (see "4.3 ATA Compatibility" on page 17) by using the IDENTIFY DRIVE command, but older BIOS use configuration information from outside the IDE/ATA interface. It has also been discovered that very old BIOS may issue an ATA READ command to detect the presence of an ATA IDE drive. Therefore, the ATA READ and IDENTIFY DRIVE commands *shall* be aborted by ATAPI Devices. It has also been discovered that some BIOS look at the status register to detect the presence of an ATA drive.

5.14.5 Default Timing

ATAPI devices compatible with this specification *shall* support ATA mode 3 timing without requiring the host system to configure the ATAPI device using any set features commands. ATAPI devices must therefore either be fast enough to always supply data at the maximum rate allowed by Mode 3 or the ATAPI device must be shipped with IORDY enabled.

ATAPI devices *shall* revert to their default interface configuration on a Power On Reset or a Hardware Reset.

**Preliminary Draft
for Review Only**

6.0 ATAPI Transport Mechanism

The Transport Mechanism provides for the hardware support to connect the host computer to the Peripheral. There will ultimately be two “Models” of operation specified, the Compatibility and Extended Capability Models. The Compatibility Model will look exactly like an ATA/IDE Drive to all existing Drivers, Operating Systems and Hardware. It will operate under many restrictions and will be required to support extra capabilities. The Extended Capability Model will be used to address issues, such as IRQ sharing and multi-threading of commands. The Extended Capability Model will be defined at a later time and will not be defined in this standard. The Compatibility Model is described in the remainder of this section.

6.1 Reset Conditions

There are three types of Reset Condition to which ATAPI Devices shall respond:

- **Power On Reset or Hardware Reset:** the Device executes a series of electrical circuitry diagnostics and sets default values, as well as executing the Master Slave Diagnostic Protocol.
- **ATAPI Soft Reset:** ATAPI Devices *shall* reset the interface circuitry according to the Set Features requirement upon receipt of the ATAPI Soft Reset Command.
- **ATA SRST:** ATAPI Devices *shall* provide the normal ATA PDIAG/ DASP sequence and initialize the task file with the ATAPI signature upon detection of SRST. No actual reset of the ATAPI device will occur, no commands that may be active will be aborted or stopped.

The Reset Conditions above are listed in order of precedence. That is, Power On or Hardware Reset *shall* take precedence over ATAPI Soft Reset, which *shall* take precedence over ATA SRST, which *shall* take precedence over all other conditions.

6.1.1 Power On or Hardware Reset

Each ATAPI Device, as it is powered on, *shall* perform appropriate internal reset operations, and internal test operations.

ATAPI Devices upon detection of reset, *shall*:

1. Clear all Commands and I/O operations in progress.
2. Return to Devices default configuration.
3. Perform the DASP / PDIAG sequence.
4. Return any ATAPI Device operating modes to their appropriate initial conditions, similar to those conditions that would be found after a normal power-on reset. MODE SELECT conditions *shall* be restored to their last saved values if saved values have been established. MODE SELECT conditions for which no values have been saved *shall* be returned to their default values.
5. Initialize the Task File Registers as follows: Status = 00h, Error = 01h, Sector Count = 01h, Sector Number = 01h, Cylinder Low = 14h, Cylinder High = EBh and Drive/Head = 00h. A value other than 00 in the status register prior to the receipt of the first ATAPI Command Packet from the host may cause the ATAPI Device to be incorrectly identified by the host as an ATA compatible disk drive. BSY = 0, following any Reset, indicates to the Host that the registers within the Task File have been initialized

6.2 ATAPI Soft Reset Command and Protocol

ATA specifies a mandatory software reset capability because it provides a recovery mechanism from a class of errors/problems that are recoverable in no other way. The current CD-ROM drivers invoke this feature at some point in their error recovery procedures today.

The ATA software reset mechanism, SRST, (bit 2 in the Device Control Register) cannot be used for ATAPI Devices, because resets issued by the ATAPI driver would also reset any attached hard disk and vice versa.

To solve this ATAPI defines an ATAPI Soft Reset command using a reserved ATA opcode which could be decoded by the interface controller hardware. The ATAPI Soft Reset command *shall* be "executed" by dedicated hardware as opposed to firmware, and the Drive Select bit will be used to qualify the one Device that will accept the ATAPI Soft Reset command. Only the ATAPI Device that is selected will be reset by the ATAPI Soft reset command.

For a software reset to be useful, it must be able to bring the drive's microprocessor back from a busy or hung condition, allowing issuance of a diagnostic or some other command. Since the microprocessor is the destination of the reset, we can't depend on it as part of the reset path. Therefore, ATAPI Soft Reset *shall* be detected/decoded by the interface controller circuitry and be routed back to the microprocessor as a hardware signal.

Upon detection of the ATAPI Reset command, *shall*:

1. Return Diagnostics Status from the Slave to the Master Drive via the PDIAG signal. The RESET COMMAND will not execute any diagnostics, but *shall* still provide the PDIAG sequence in order to provide Diagnostic Status that may be expected by the Master Device.
2. Set BSY when the command is decoded. When the reset sequence in the Device is complete the Busy status will be cleared. This will be the only status returned to the host by the ATAPI Soft Reset command.
3. Initialize the task file with the same information as after a Power On Reset. See section 6.1.1, "Power On or Hardware Reset", on page 35 for a description of the initialization sequence, with the exception of the DRV bit which *shall* remain unchanged.

6.3 ATAPI Implementation of ATA SRST

The ATA software reset mechanism, SRST, (bit 2 in the Device Control Register) cannot be used for ATAPI Devices, because resets issued by the ATAPI driver would also reset any attached hard disk and vice versa. To solve this ATAPI defines an ATAPI Soft Reset command using a reserved ATA opcode which could be decoded by the interface controller hardware.

To maintain Master / Slave compatibility with ATA disk drives and prevent detection of ATAPI Devices by non ATAPI-aware BIOS, ATAPI Devices *shall* implement the following upon receipt of an ATA SRST:

1. Follow the SRST Sequence defined in "Figure 5 - SRST Sequence" on page 37, and not the sequences shown in the ATA Specification.
2. Initialize the task file with Status = 00h or 10h, Error = 01h, Sector Count = 01h, Sector Number = 01h, Cylinder Low = 14h, Cylinder High = EBh and Drive/Head = 00h.
3. Maintain the functionality of the DSC bit, to indicate completion of any immediate command executing when SRST was detected.
4. Continue executing commands or play operations.
5. Leave Mode settings or Set Feature settings unchanged.
6. If an ATAPI Device detects SRST while DRQ=1 and the ATAPI Device is selected, then and only then, *shall* an ATAPI Device abort a command in progress on receipt of an SRST.

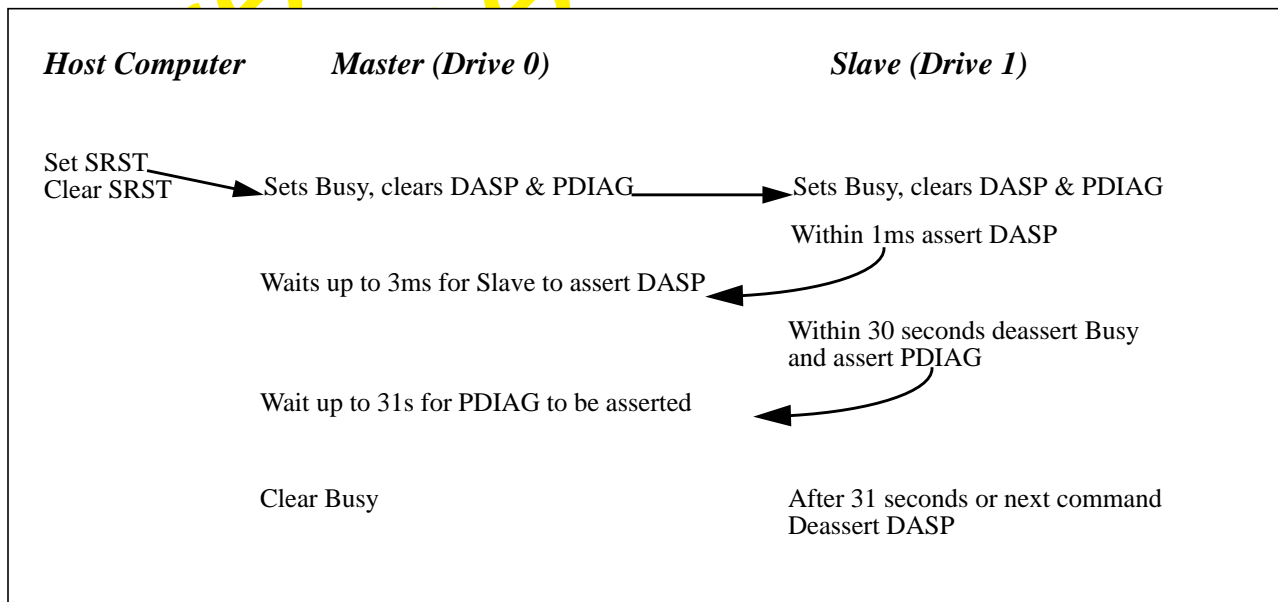

Figure 5 - SRST Sequence

6.4 Physical Connection

The ATAPI Devices are selected by the Address field in the Drive Select Register. When a single Device is attached to the interface it *shall* be set as Device 0. When the ATAPI Device is attached along with an ATA Mass Storage Device, the ATAPI Device will be set as Device 1 and respond as a Slave.

Table 4 - Preferred Drive Connection

Primary Cable		Secondary Cable		Notes
Master	Slave ¹	Master	Slave	
ATA Drive				Normal single cable
ATAPI Device				Normal single cable
ATA Drive	ATAPI Device			Single cable with CD-ROM
ATAPI Device	ATAPI Device			Support two ATAPI Devices on the Same Cable.
ATA Drive	ATA Drive			Two drives on one cable
ATA Drive		ATAPI Device		One drive and a CD-ROM with two cables
ATA Drive		ATA Drive	ATAPI Device	Two drives and CD-ROM with two cables
ATA Drive	ATA Drive	ATA Drive	ATAPI Device	Three drives and CD-ROM with two cables

1. The ATAPI Device *shall* be capable of either Master or Slave operation.

6.5 Register Mapping

Communication to or from the Devices is through I/O Registers that route the input or output data to or from registers (selected) by a code on signals from the host (CS1FX-, CS3FX-, DA2, DA1, DA0, DIOR- and DIOW-).

6.6 ATAPI Register Map (Packet Command)

Logic conventions are: A = signal asserted, N = signal negated, x = does not matter which it is

Table 5 - I/O Port Functions/Selection Addresses (Compatibility Model)

Addresses					Functions	
CS1FX	CS3FX	DA2	DA1	DA0	Read (DIOR-)	Write (DIOW-)
					Control Block Registers	
N	A	0	0	0	Floppy A Status	Unused
N	A	0	0	1	Floppy B Status	Unused
N	A	0	1	0	Unused	Floppy Digital Output Register
N	A	0	1	1	Floppy ID / Tape Control	RESERVED
N	A	1	0	0	Floppy Controller Status	RESERVED
N	A	1	0	1	Floppy Data Register	
N	A	1	1	0	Alternate ATAPI Status	Device Control
N	A	1	1	1	Diskette Change/Drive Address	Not Used
					Command Block Registers	
A	N	0	0	0	Data	
A	N	0	0	1	ATAPI Error Register	ATAPI Features
A	N	0	1	0	ATAPI Interrupt Reason Register	
A	N	0	1	1	Reserved For SAM TAG Byte	
A	N	1	0	0	ATAPI Byte Count Register (bits 0-7)	
A	N	1	0	1	ATAPI Byte Count Register (bits 8-15)	
A	N	1	1	0	Drive Select	
A	N	1	1	1	ATAPI Status	ATA Command

With the exception of the Data Register, all the ATAPI registers are referenced using Byte (8 Bit) Read and Writes. The Data Register is ALWAYS referenced as a 16 bit word.

The following table is shown for reference only, no word references to the registers (Other than the data register) are allowed by this specification.

Table 6 - Word Mapping of Task File Registers

Typical Addr	Functions			
	Read (DIOR-)		Write (DIOW-)	
Control Block Registers				
3x0	Floppy B Status	Floppy A Status	Unused	Unused
3x2	Floppy ID / Tape Control	Unused	Reserved	Floppy Digital Output
3x4	Floppy Data Register	Floppy Controller Status	Floppy Data Register	Reserved
3x6	Change/Drive Address	Alternate ATAPI Status	Unused	ATAPI Device Control
Command Block Registers				
1x0	Data Register		Data Register	
1	ATAPI Error Register		ATAPI Feature Register	
1x2	Reserved for SAM Tag	ATAPI Interrupt Reason	Reserved for SAM Tag	Sector Count
1x4	ATAPI Byte Count Register		ATAPI Byte Count Register	
1x6	ATAPI Status	Drive Select Register	ATA Command Register	Drive Select Register

D7	D6	D5	D4	D3	D2	D1	D0	
BSY	DRDY	Reserved	DSC	DRQ	CORR	Reserved	CHECK	Read

Figure 6 - ATAPI Status Register (ATA Status Register)

DRDY, DSC, CORR and CHECK *shall* only be valid at the end of the completion of the command.

- Bit 7 BSY Busy is set whenever the drive has access to the Command Block.
- Bit 6 DRDY Indicates that the drive is capable of responding to an ATA command.
- Bit 4 DSC Seek Complete indication, used for overlapped Seek operation.
- Bit 3 DRQ Data Request - Indicates that the device is ready to transfer a word or byte of data between the host and the drive. The information in the ATAPI Interrupt Reason will also be valid during a Packet Command when the DRQ is set.
- Bit 2 CORR Indicates if a Correctable Error occurred.
- Bit 0 CHECK Indicates that an error occurred during execution of the previous command. The bits in the Error Register contains the Sense Key and Code.

D7	D6	D5	D4	D3	D2	D1	D0	
Sense Key				MCR	ABRT	EOM	ILI	Read

Figure 7 - ATAPI Error Register (ATA Error Register)

Bits 7-4 Sense Key The sense key is defined in "Table 124 - Sense Key Descriptions" on page 157.

Bit 3	MCR	Media Change Requested, is used and defined as in the ATA Standard.
Bit 2	ABRT	Aborted Command, is used and defined as in the ATA Standard.
Bit 1	EOM	End Of Media Detected.
Bit 0	ILI	Illegal Length Indication.

D7	D6	D5	D4	D3	D2	D1	D0	Write
Reserved	Reserved for Tag Type			Reserved		DMA		

Figure 8 - ATAPI Feature Register (ATA Feature Register)

Bit 7	Reserved	Reserved for future enhancement.
Bit 6,5,4	Reserved	Reserved for Tag Type.
Bit 3,2,1	Reserved	Reserved for future enhancement.
Bit 0	DMA (Optional)	Any data for the Command will be transferred via the DMA interface. Note this does not apply for the Command Packet.

D7	D6	D5	D4	D3	D2	D1	D0	R/W
Byte Count (Bits 0-7)								
Byte Count (Bits (8-15))								R/W

Figure 9 - ATAPI Byte Count Register (ATA Cylinder High/Low Register)

The Byte Count is used for PIO only; it is ignored on DMA mode operations. The count *shall* be set prior to the issuance of the Packet Command. The count contains the total transfer size for commands that transfer only one group of data (e.g. Mode Sense / Select, Inquiry) For commands that require multiple DRQ Interrupts (e.g. Read, or Write) the count is set to the desired transfer size. When any data is to be transferred, the ATAPI Device will set the Byte Count to the amount of data that the Host *shall* transfer and then issue the DRQ Interrupt. The contents of this register will not change during the DRQ.

D7	D6	D5	D4	D3	D2	D1	D0	
Reserved						IO	CoD	Read

Figure 10 - ATAPI Interrupt Reason Register (ATA Sector Count Register)

Bit 0 CoD Command or Data. When this bit is zero then the information being transferred is user data, when one then the data is Command.

Bit 1 IO Direction for the Information transfer, where in to the Host is indicated by a value of one and out to the device is zero.

IO	DRQ	CoD	
0	1	1	Command - Ready to Accept Command Packet Bytes
1	1	1	Message (Future) - Ready to Send Message data to Host
1	1	0	Data To Host- Send command parameter data (e.g. Read Data) to the host
0	1	0	Data From Host - Receive command parameter data (e.g. Write Data) from the host
1	0	1	Status - Register contains Completion Status

D7	D6	D5	D4	D3	D2	D1	D0	
1	Reserved	1	DRV	Reserved for SAM LUN				R/W

Figure 11 - ATAPI Drive Select Register (ATA Drive / Head Select Register)

Bit 4 DRV This bit selects either Device 0 (DRV=0) or 1 (DRV=1).

D7	D6	D5	D4	D3	D2	D1	D0	
Reserved				1	SRST	nIEN	0	Write

Figure 12 - ATAPI Device Control Register (ATA Device Control Register)

Bit 2 SRST This bit is the Software Reset. The ATAPI Device *shall* follow the reset sequence for SRST defined in "6.3 ATAPI Implementation of ATA SRST" on page 37. There is also a new reset capability for ATAPI Devices utilizing a RESET COMMAND (see "6.2 ATAPI Soft Reset Command and Protocol" on page 36).

Bit 1 nIEN This bit enables/disables the interrupt to the host. When nIEN=0 and the device is selected, INTRQ *shall* be enabled through a tri-state buffer. When nIEN=1 or the device is not selected, the INTRQ signal *shall* be in a high impedance state

7.0 CD-ROM Model

CD-ROM devices permit reading data from a rotating media. Writing the media is not currently supported, but will be in the future (CD-WO and CD-MO). Data transfer can begin with any of the consecutively numbered logical blocks. Data on CD-ROM devices is addressed the same as for (magnetic) direct-access devices. Some CD-ROM devices support a separate information stream (e.g. audio and/or video but referred to as audio in this Section) transmitted via a connection other than the AT Bus. This specification defines commands for controlling these other information streams for CD-ROM devices.

CD-ROM drives are designed to work with any disc that meets IEC. Many new drives read CD-ROM data discs, digital audio discs, and audio-combined discs (i.e. some tracks are audio, some tracks are data).

7.1 New Capabilities Since the SCSI-2 Standardization

Unfortunately, the introduction of Photo CDs (with multiple sessions), CD-ROM XA Format (two different format modes), and CD-I has occurred after the standardization effort. In addition, the SCSI standard did not provide a method to return the CD-DA data. As is characteristic with “new” functionality, each vendor has devised their own solutions. This ATAPI Proposal has taken the “Common Command Set (CCS)” approach to the problem and created a minimal mandatory command set that includes capabilities that are not currently standardized.

7.2 CD-ROM Media Organization

The formats written on the CD-ROM and CD-DA (Digital Audio) media require special interfacing considerations.

NOTE This subsection contains a number of terms that have special meanings peculiar to CD-ROM technology or that may be unfamiliar to many readers of this Specification. The glossary defines these terms.

Discs may contain either audio, data or a mixture of the two. "Table 7 - Example Mixed Mode CD-ROM Disc Layout" on page 44 gives an example of an audio-combined disc to illustrate the relationship between the logical block addresses reported and the MSF address encoded on the media.

NOTE: The term “frame” is used in two different ways in the CD-ROM media standard. The intended meaning can only be determined from the context. Whenever possible, this description replaces the larger data unit with the more familiar term sector. The primary exception to this policy is the use of frame when referring to the MSF address. In the MSF context, one frame (F field unit) equals one sector. On a typical two channel CD-DA media, each frame (F field unit) is played in 1/75th of a second.

Table 7 - Example Mixed Mode CD-ROM Disc Layout

Block Description	Logical Address (Decimal)	Track Relative Logical Address	Absolute MSF Address ¹	Track and Index	Track Relative MSF address	Sector is Info or is Pause	Mode Audio or Data	CD-ROM Data Mode ²
Lead-in area ³	---	---	---	0/-	---	---	Audio	---
Pre-gap ³	---	---	00/00/00	1/0	00/02/00	Pause	Data	Null
1st track data	0000 ⁴	0	00/02/00 ⁵	1/1	00/00/00	Info	Data	L-EC
2nd track data	6000 ⁴	0	01/16/00 ⁵	2/1	00/00/00	Info	Data	L-EC
	7500	1500	01/2A/00	2/2	00/16/00	Info	Data	L-EC
Post-gap	9000	3000	02/02/00	2/3	00/28/00	Pause	Data	Null
Pause-silence	9150	-150 ⁶	02/04/00	3/0	00/02/00 ⁷	Pause	Audio	---
3rd track audio	9300 ⁸	0	02/04/00 ⁹	3/1	00/00/00	Info	Audio	---
	1400	2250	02/22/00	3/2	00/1E/00	Info	Audio	---
4th track audio	21975 ⁸	0	04/35/00 ⁹	4/1	00/00/00	Info	Audio	---
Pre-gap part 1	30000	-225 ⁶	06/28/00	5/0	00/03/00	Pause	Audio	---
Pre-gap part 2	30075	-150	06/29/00	5/0	00/02/00	Pause	Data	Null
5th track data	30225	0	06/2B/00	5/1	00/00/00	Info	Data	L-EC
Last information	263999 ¹⁰	233 774	3A/27/4A	5/1	33/38/4A	Info	Data	L-EC
Post-gap	---	233 775	3A/28/00	5/2	33/39/00	Pause	Data	Null
Lead-out track	264000 ¹¹	0	58/42/00 ¹²	AA/ ¹³	00/00/00	Pause	Audio	---

1. Absolute MSF address repeated in the header field of data blocks.
2. The CD-ROM data mode is stored in the header of data tracks. This indicates that the block is part of a data pre-gap or post-gap (null), that this is a data block using the auxiliary field for L-EC symbols (ECC - CD-ROM data mode one), or that this is a data block using the auxiliary field for user data (CD-ROM data mode two).
3. Table of contents information is stored in the sub-channel of lead-in area. The lead-in area is coded as track zero. Track zero and the initial 150 sector pre-gap (or audio pause) are not accessible with logical addressing.
4. Exact value returned by READ TOC command.
5. Value stored in table of contents with zero tolerance.
6. Track relative logical addresses are negative in the pre-gap areas. Pre-gap areas have index values of zero.
7. Track relative MSF value decreases to 0 in pre-gap areas.
8. Value returned by READ TOC command plus or minus 75 blocks.
9. Value stored in table of contents plus or minus 75 sectors.
10. Minimum value returned by READ CD-ROM CAPACITY; exact value depends on encoding of this track and the lead out track and whether this is derived from the TOC data.
11. Value returned by READ TOC command; exact, if lead-out track is encoded as data, or plus or minus 75 blocks if encoded as audio.
12. Value stored in table of contents; exact, if lead-out track is coded as data, or plus or minus 75 blocks if coded as audio.
13. Lead-out track number is defined as 0AAh.

The physical format defined by the CD-ROM media standards provides 2352 bytes per sector. For usual computer data applications, 2048 bytes are used for user data, 12 bytes for a synchronization field, 4 bytes for a sector address tag field and 288 bytes - the auxiliary field - for L-EC (CD-ROM data mode 1). In less critical applications, the auxiliary field may also be used for user data (CD-ROM data Mode 2 / Form 2).

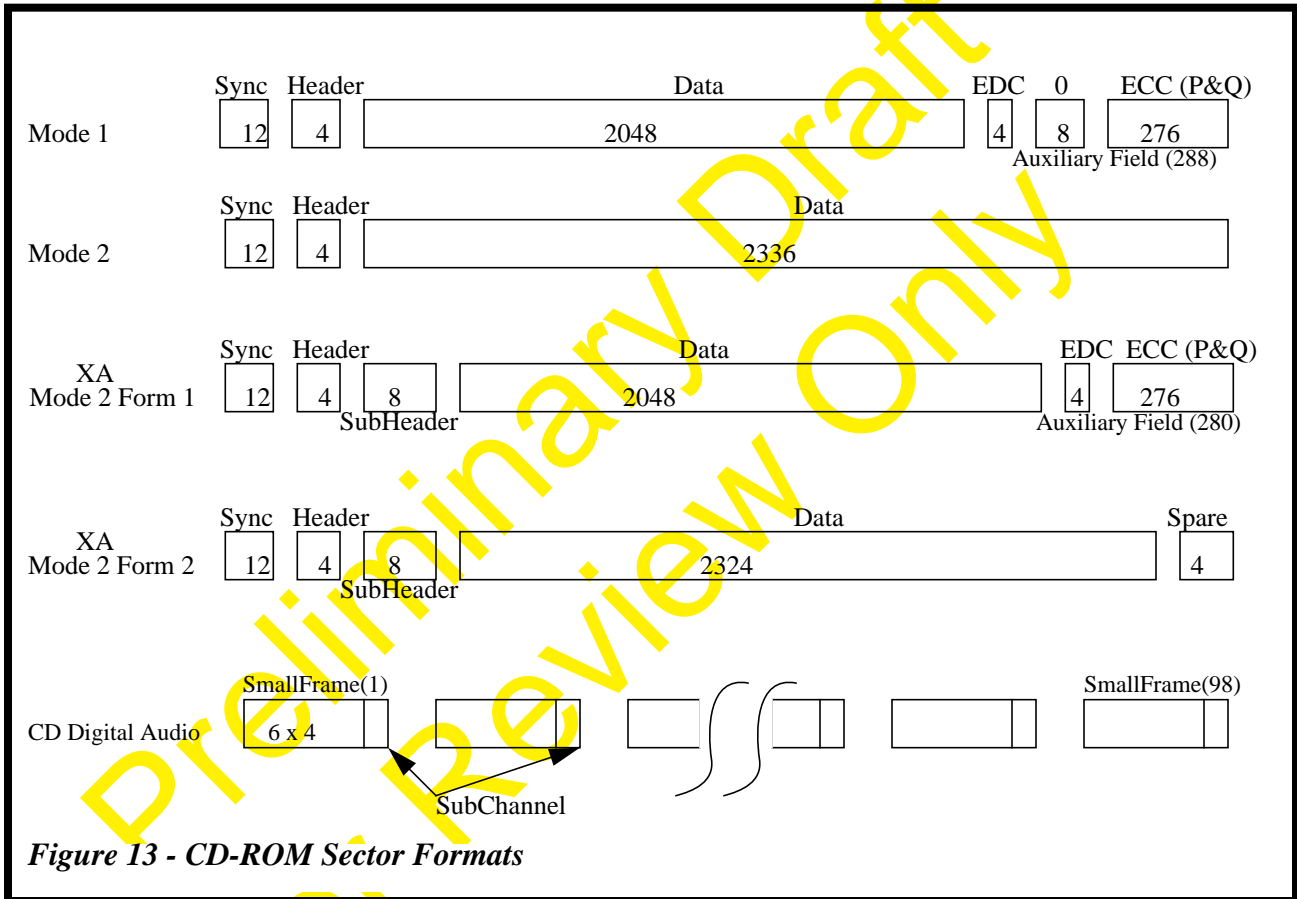

A CD-ROM physical sector size is 2048, 2052, 2056, 2324, 2332, 2336, 2340 or 2352 bytes per sector. These values correspond to the user data plus various configurations of header, subheader and EDC/ECC.

This same area of the CD-ROM or CD audio media may store 1/75th of a second of two channel audio information formatted according to the CD-DA specification. (These audio channels are usually the left and right components of a stereo pair.) An audio only density code value can be used to declare an area of the media to be invalid for data operations.

For data and mixed mode media (those conforming to ISO/IEC 10149), logical block address zero *shall* be assigned to the block at MSF address 00/02/00. For audio media (those conforming only to IEC 908), logical block address zero *shall* be assigned to the actual starting address of track 1. This may be approximated by using the starting address of track 1 contained in the table of contents (TOC) or by assigning logical block address zero to the block at MSF address 00/02/00.

Logical addressing of CD-ROM information may use any logical block length. When the specified logical block length is an exact divisor or integral multiple of the selected number of bytes per CD-ROM sector, the device *shall* map (one to one) the bytes transferred from CD-ROM sectors to the bytes of logical blocks. For instance, if 2048 bytes are transferred from each CD-ROM sector (specified by the CD-ROM density code value), and the logical block length is 512 bytes, then each CD-ROM sector *shall* map to exactly four logical blocks. This Specification does not define the mapping of logical block lengths which do not evenly divide or are not exact multiples of the selected number of bytes per CD-ROM sector.

A track may be viewed as a partition of the CD-ROM address space. A CD-ROM media contains from one to ninety-nine tracks. All information sectors of a track are required to be of the same type (audio or data) and mode. Each change in the type of information on the disc requires a change in track number. A disc containing both audio and data would have at least two tracks, one for audio and one for data.

The tracks of a CD media are numbered consecutively with values between 1 and 99. However, the first information track may have a number greater than 1. Tracks have a minimum length of 300 sectors including any transition area that is part of a track.

The CD-ROM media standards require transition areas between tracks encoded with different types of information. In addition, transition areas may be used at the beginning or end of any track. For audio tracks the transition areas are called pause areas. For data tracks, transition areas are called pre-gap and post-gap areas. See "Table 7 - Example Mixed Mode CD-ROM Disc Layout" on page 44 for an example. The IEC 908 and ISO/IEC 10149 standards specify minimum time durations for these areas. Maximum time durations are not specified.

Transition areas are formatted and the logical address continues to increment through transition areas. Some media (i.e. discs with only one track) may not have transition areas. The means to determine the location of the transition areas is vendor or application-specific and is addressed by other standards (e.g. ISO 9660).

CD-ROM is a unique device in the respect that some logical blocks on a disc may not be accessible by all commands. SEEK commands may be issued to any logical block address within the reported capacity of the disc. READ commands cannot be issued to logical blocks that occur in some transition areas, or to logical blocks within an audio track. PLAY commands cannot be issued to logical blocks within a data track.

CD-ROM media have lead-in and lead-out areas. These areas are outside of the user-accessible area as reported in the READ CD-ROM CAPACITY data. The lead-in area of the media is designated track zero. The lead-out area is designated track 0AAh. The sub-channel Q in the lead-in track contains a table of contents (TOC) of the disc.

NOTE: The READ CD-ROM CAPACITY command returns the logical block address of the last block prior to the lead-out area. This location may be in a transition area and therefore not a valid address for read operations.

The table of contents gives the absolute MSF location of the first information sector of each track. Control information (audio/data, method of audio encoding, etc.) for each track is also given in the TOC. However, the TOC does not distinguish between the different modes of data tracks (i.e. CD-ROM Data Mode 1 vs. CD-ROM Data Mode 2).

The MSF locations of the beginning of data tracks in the TOC are required to be accurate; however, the TOC values for audio tracks have a tolerance of plus or minus 75 sectors. Information from the TOC can be used to reply to a READ CD-ROM CAPACITY command. When this is done, the drive implementor *shall* consider the possible tolerances and return a value that allows access to all information sectors.

An index is a partition of a track. Pre-gap areas are encoded with an index value of zero. Pause areas at the beginning of audio tracks are also encoded with an index value of zero. The first information sector of a track has an index value of one. Consecutive values up to 99 are permitted. Index information is not contained in the TOC. Not all sectors are encoded with the index value in the Q-sub-channel data (the requirement is 9 out of 10). A sector without an index value is presumed to have the same index as the preceding sector.

Tracks and indexes are not defined to be any particular length, (except for a minimum track length of 300 sectors.) A CD disc may be created with a single information track that has a single index; or with 99 information tracks, each with 99 indexes.

The sub-channel information which is part of each sector includes a track relative MSF location value giving the distance from the first information sector of the track. On the media, this value decreases during the pre-gap area (sectors with index values of 0) and increases for the rest of the track. The data, returned by the READ SUB-CHANNEL command with MSF bit set to zero, converts this to a track relative logical block address (TRLBA). The TRLBA is continual-

ly increasing over the whole track, and pre-gap areas *shall* return negative values. When the MSF bit in the read sub-channel command is set to one, the MSF track relative location value from the media is reported without change.

Note: The purpose of accessing MSF addresses less than 00M 02S 00F is to retrieve information, such as packet size, from incrementally written discs. This information exists in the track descriptor block in the pre-gap area. Users can read this information by scanning the area between 00M 01S 00F to 00M 02S 00F. While the media may contain multiple redundant copies of the pre-gap data, the device *shall* only return one copy. The drive may not be able to read 00M 00S 00F since there is no Sub-Q information before this frame. Refer to CD-ROM Orange book for additional details.

7.3 CD-ROM Physical Data Format

The physical format of CD-ROM and CD-DA media uses a smaller unit of synchronization than the more familiar magnetic or optical recording systems. The basic data stream synchronization unit is a small frame. This is not the same large frame (sector) as referred to in the MSF unit. Each small frame consists of 588 bits. A sector on CD-ROM media consists of 98 small frames.

A CD-ROM small frame consists of:

1. 1 synchronization pattern (24+3 bits)
2. 1 byte of sub-channel data (14+3 bits)
3. 24 bytes of data (24 x (14+3) bits)
4. 8 bytes of CIRC code (8 x (14+3) bits) Total: 588 bits.

Data, sub-channel and CIRC bytes are encoded with an 8-bit to 14-bit code; then three merging bits are added. The merging bits are chosen to provide minimum low-frequency signal content and optimize phase lock loop performance.

7.3.1 Frame Format for Audio

Each small frame of an audio track on a two-channel CD-DA or CD-ROM media consists of six digitized 16-bit samples of each audio channel. These 24 bytes of data are combined with a synchronization pattern, CIRC bytes and a sub-channel byte to make a frame. Each frame takes approximately 136.05 μ s to play. This gives a sampling rate of 44.1 kHz for each channel. The sub-channel information creates the higher level sector grouping for audio tracks.

7.3.2 Sector Format for Data

The data bytes of 98 small frames comprise the physical unit of data referred to as a sector. (98 small frames times 24 bytes per small frame equals 2352 bytes of data per sector.)

A sector that contains CD-ROM Data Mode 1 data has the following format:

1. 12-byte synchronization field
2. 4-byte CD-ROM data header
 - Absolute M field
 - Absolute S field
 - Absolute F field
 - CD-ROM data mode field
3. 2048-byte user data field

4. 4-byte error detection code
5. 8 bytes zero
6. 276-byte layered error correction code

A sector that contains CD-ROM Data Mode 2 data has the following format:

1. 12-byte synchronization field
2. 4-byte CD-ROM data header
 - Absolute M field
 - Absolute S field
 - Absolute F field
 - CD-ROM data mode field
3. 2336-byte user data field (2048 bytes of mode 1 data plus 288 bytes of auxiliary data)

NOTE Many drives are capable of returning CD-ROM data mode one data in a CD-ROM data mode two format. This allows the user to investigate the error detection and error correction codes. However data encoded as CD-ROM data mode two cannot be read as CD-ROM data mode one data.

7.3.3 Sub-channel Information Formats

The sub-channel byte of each frame is assigned one bit for each of the 8 sub-channels, designated P, Q, R, S, T, U, V, W.

Sub-channel P is a simple flag bit that may be used for audio muting control and track boundary determination.

Sub-channel Q has a higher level of structure. All the sub-channel Q bits of a sector define the sub-channel Q information block. (For audio tracks, decoding the Q sub-channel is the only way to distinguish sector boundaries.)

The sub-channel Q block consists of 98 bits, one bit from each small frame in a sector. Three formats are defined for the sub-channel Q information block. The first format provides location information and is defined as follows:

1. 2-bit sub-channel synchronization field
2. 4-bit ADR field (defines the format)
3. 4-bit control field (defines the type of information in this sector)
4. 8-bit track number
5. 8-bit index number
6. 24-bit track relative MSF address
7. 8 bits Reserved (0)
8. 24-bit Absolute MSF address
9. 16-bit CRC error detection code

This format is required to exist in at least nine out of ten consecutive sectors.

The second and third formats are optional. If used, they *shall* exist in at least one out of 100 consecutive sectors. They include the absolute frame byte of the MSF address to provide location information continuity.

The second format gives the catalogue number of the disc (UPC/EAN bar code number). This information is constant over the whole media.

The third format gives the International Standard Recording Code (ISRC) for each track. The ISRC is defined in ISO 3901. This format is not present on lead-in or lead-out tracks and may change only after the track number changes.

7.4 CD Audio Error Reporting

PLAY AUDIO commands with the immediate bit set in the audio control mode return status as soon as the command has been validated (which may involve a seek to the starting address). The playback operation continues and may complete without notification to the Host Computer. Error termination of audio operations *shall* be reported to the Host Computer by returning immediate CHECK CONDITION status to the next command (except for REQUEST SENSE and INQUIRY.) The deferred error sense data is used to indicate that the error is not due to the current command.

The status of the play operation may be determined by issuing a REQUEST SENSE command. The sense key is set to NO SENSE and the audio status is reported in the additional sense code qualifier field.

7.5 CD-ROM Ready Condition/Not Ready Condition

The ready condition occurs after a cartridge is inserted and the drive has performed its initialization tasks. These may include reading the table of contents from the media. This “Ready” is different from and *shall* not be confused with the ATA Ready Status. A check condition status will be returned for the not ready condition only for commands that require or imply a disc access.

A not ready condition may occur for the following reasons:

1. There is no cartridge inserted.
2. The drive is unable to load or unload the cartridge.
3. The drive is unable to recover the table of contents.

7.5.1 Packet Command Not Ready Status Utilization

Table 8 - Not Ready Error Reporting (by Command)

Command	Opcode	May Return Not Ready Error
INQUIRY	12h	No
MODE SELECT(10)	55h	No
MODE SENSE(10)	5Ah	No
READ(10)	28h	Yes
READ(12)	A8h	Yes
READ CD-ROM CAPACITY	25h	Yes
READ HEADER	44h	Yes
READ SUB-CHANNEL	42h	Yes
READ CD	BEh	Yes
READ CD MSF	B9h	Yes
READ CD TRACK/INDEX	D6h	Yes
READ TOC	43h	Yes
REQUEST SENSE	03h	No
START STOP UNIT	1Bh	Yes
TEST UNIT READY	00h	Yes
SET CD-ROM SPEED	BBh	No
REZERO UNIT	01h	Yes
SEEK	2Bh	Yes
PAUSE/RESUME	4Bh	Yes
PLAY AUDIO	45h	Yes
PLAY AUDIO EXTENDED	A5h	Yes
PLAY AUDIO MSF	47h	Yes
PLAY TRACK RELATIVE(10)	49h	Yes
PLAY TRACK RELATIVE(12)	A9h	Yes
AUDIO TRACK SEARCH	D8h	Yes
AUDIO SCAN	BAh	Yes
PREVENT/ALLOW MEDIUM REMOVAL	1Eh	See Actions for Lock / Unlock / Eject on page 116 for Actions allowed

7.6 CD-ROM Address Reporting Formats (MSF bit)

Several CD-ROM specific commands can return addresses either in logical or in MSF format. The READ HEADER, READ SUB-CHANNEL and READ TABLE OF CONTENTS commands have this feature.

Table 9 - MSF Address Format

Bit Byte	7	6	5	4	3	2	1	0
0	Reserved							
1	M Field							
2	S Field							
3	F Field							

An MSF bit of zero requests that the logical block address format be used for the CD-ROM absolute address field or for the offset from the beginning of the current track expressed as a number of logical blocks in a CD-ROM track relative address field. This track relative logical block address (TRLBA) value is reported as a negative value in twos-complement notation for transition areas that have decreasing MSF encoded relative addresses.

An MSF bit of one requests that the MSF format be used for these fields. In certain transition areas, the relative MSF addresses are decreasing positive values. The absolute MSF addresses are always increasing positive values. The M, S, and F fields are expressed as binary numbers. Sensing Support for CD-Audio Commands

If any commands related to audio operations are implemented, then all the AUDIO commands *shall* be implemented. To allow a method for the Host Computer to determine if audio operations are supported, an ATAPI CD-ROM Drive responding to a PLAY AUDIO command which has a transfer length of zero, with CHECK CONDITION status, and setting the sense key to ILLEGAL REQUEST does not support audio operations.

7.7 Error Reporting

If any of the following conditions occur during the execution of a command, the ATAPI CD-ROM Drive *shall* return CHECK CONDITION status. The appropriate sense key and additional sense code *shall* be set. The following list illustrates some error conditions and the applicable sense keys. The list does not provide an exhaustive enumeration of all conditions that may cause the CHECK CONDITION status.

Table 10 - Error Conditions and Sense Keys

Condition	Sense Key
Invalid logical block address	ILLEGAL REQUEST
Unsupported option requested	ILLEGAL REQUEST
Attempt to read a blank block	ILLEGAL REQUEST
Attempt to play a data block as audio	ILLEGAL REQUEST
ATAPI CD-ROM Drive reset or medium change since last command	UNIT ATTENTION
Self diagnostic failed	HARDWARE ERROR
Unrecovered read error	MEDIUM ERROR / HARDWARE ERROR
Recovered read error	RECOVERED ERROR
Overrun or other error that might be resolved by repeating the command	ABORTED COMMAND

In the case of an invalid logical block address, the sense data information field *shall* be set to the logical block address of the first invalid address.

In the case of an attempt to read a blank or previously unwritten block, the sense data information field *shall* be set to the logical block address of the first blank block encountered. The data read up to that block *shall* be transferred.

There are other special error situations for CD-ROM devices. In the following cases the sense key *shall* be set to ILLEGAL REQUEST and the additional sense code set to END OF USER AREA ENCOUNTERED ON THIS TRACK:

1. a post-gap area is encountered (i.e. a block with CD-ROM Data Mode 0);
2. a pre-gap area is encountered (i.e. a block with index equal to 0);
3. The information type (Data Mode vs. Audio etc.) changes.

When not performing audio playback, if the logical block address requested is not within a data track, the command *shall* be terminated with CHECK CONDITION status. The sense key *shall* be set to ILLEGAL REQUEST and the additional sense code set to ILLEGAL MODE FOR THIS TRACK. This applies to audio-combined and audio media.

I

Preliminary Draft
for Review Only

Intentionally Left Blank

8.0 CD-ROM ATA (Task File) Commands

8.1 ATA (Task File) Command Implementation Requirements

This section details the Commands that the CD-ROM Device *shall* support from the ATA Standard definition of the commands.

Table 11 - ATA Command and Status Usage for ATAPI CD-ROM Devices

Command	used	Code	Error Register						Status Register				
			BBK	UNC	IDNF	ABRT	TKONF	AMNF	DRDY	DWF	DSC	CORR	ERR
Acknowledge Media Change	N	DB				V							V
ATAPI Soft Reset	M	08											
Boot - Post-boot	N	DC				V							V
Boot - Pre-boot	N	DD				V							V
Check Power Mode	M	E5				V			V	V	V		V
Door Lock	N	DE				V							V
Door Unlock	N	DF				V							V
Execute Drive Diagnostics	M	90	Special Drive Diagnostic Errors										V
Format Track	N ¹	50				V							V
Identify Drive	N	EC				V							V
Idle	O	E3				V			V	V	V		V
Idle Immediate	M	E1				V			V	V	V		V
Initialize Drive Parameters	N ¹	91				V							V
NOP	M	00				V							V
ATAPI Pkt. Command	M	A0	Contains Packet Command Status						V			V	V
ATAPI Identify Device	M	A1				V			V		V		V
Read Buffer	N	E4				V							V
Read DMA (w/retry)	N	C8				V							V
Read DMA (wo/retry)	N	C9				V							V
Read Long (w/retry)	N	22				V							V
Read Long (wo/retry)	N ¹	23				V							V
Read Multiple	N	C4				V							V
Read Sector(s) (w/retry)	N ¹	20				V							V
Read Sector(s) (wo/retry)	N ¹	21				V							V
Read Verify Sector(s) (w/retry)	N ¹	40				V							V
Read Verify Sector(S) (wo/retry)	N ¹	41				V							V
Recalibrate	N	1x				V							V
Seek	N	7x				V							V
Set Features	M	EF				V			V	V	V		V
Set Multiple Mode	N	C6				V							V
Sleep	M	E6				V			V	V	V		V
Standby	O	E2				V			V	V	V		V
Standby Immediate	M	E0				V			V	V	V		V
Write Buffer	N	E8				V							V
Write DMA (w/retry)	N	CA				V							V
Write DMA (wo/retry)	N	CB				V							V

Table 11 - ATA Command and Status Usage for ATAPI CD-ROM Devices

Command	used	Code	Error Register						Status Register				
			BBK	UNC	IDNF	ABRT	TKONF	AMNF	DRDY	DWF	DSC	CORR	ERR
Write Long (w/retry)	N ¹	32				V							V
Write Long (wo/retry)	N ¹	33				V							V
Write Multiple	N	C5				V							V
Write Same	N	E9				V							V
Write Sector(s) (w/retry)	N ¹	30				V							V
Write Sector(s) (wo/retry)	N ¹	31				V							V
Write Verify	N	3C				V							V
Invalid Command Code						V			V	V	V		V

V = valid on this command
Y = Used by the CD-ROM ATAPI Drive, as specified by the ATA Standard
N = Not supported by ATAPI CD-ROM Drives
M = Mandatory for ATA
Shaded = Commands utilized by the ATAPI CD-ROM Drive

1. This command is specified as Mandatory for ATA, but *shall* NOT be supported by ATAPI Devices

8.1.1 ATAPI Soft Reset

Note: For performance reasons, a soft reset may not force reading of TOC.
See "6.2 ATAPI Soft Reset Command and Protocol" on page 36

8.1.2 Check Power Mode

This command checks the power mode.

If the drive is in, going to, or recovering from the Standby Mode, the drive *shall* set BSY, set the Sector Count Register to 0x00, Clear BSY, and generate an interrupt.

If the drive is in Idle Mode, the drive *shall* set BSY, set the Sector Count Register to 0xFF, clear BSY, and generate and Interrupt.

8.1.3 Execute Drive Diagnostics

This command *shall* perform the internal diagnostic tests implemented by the drive. The DRV bit is ignored. Both drives, if present, *shall* execute this command. See the ATA Standard (X3T9.2/791D) for more information.

Implementer's Note: ATAPI device drivers issuing the Execute Diagnostics command will cause all ATA and ATAPI devices to execute a diagnostic command resulting in a device reset. To prevent unwanted resets and or driver compatibility issues, ATAPI drivers should not issue the Execute Diagnostics command. The command is implemented by ATAPI devices for ATA compatibility only.

8.1.4 Idle Immediate

This command causes the drive to set BSY, enter the Idle Mode, clear BSY, and generate an interrupt. The interrupt is generated even though the drive may not have fully transitioned to Idle Mode.

8.1.5 Nop

This command enables a host which can only perform 16-bit register accesses to check drive status. The drive *shall* respond as it does to an unrecognized command by setting Abort in the Error Register, Error in the Status Register, clearing Busy in the Status Register, and asserting INTRQ.

Preliminary Draft
for Review Only

8.1.6 Packet Command

See section 5.2, "PACKET Command", on page 21.

8.1.7 ATAPI Identify Device

The ATAPI IDENTIFY DEVICE command enables the host to receive parameter information from the drive. The parameter words in the buffer have the arrangement and meaning defined in the table below. All reserved bits or words *shall* be zero. Although many of the fields of information returned by the ATAPI Identify Device command are inappropriate for a CD-ROM drive, the fields that *shall* be returned with meaningful information are shown in "Table 12 - Identify Drive, Fields Supported by CD-ROM".

Like all ATAPI commands (A0h, A1h and 08h), this command can be issued regardless of the state of the DRDY.

Table 12 - Identify Drive, Fields Supported by CD-ROM

Word	Description	Used
0	General Configuration	Mandatory
1	Cylinders	No
2	Reserved	No
3	Heads	No
4	Number of unformatted bytes per track	No
5	Number of unformatted bytes per sector	No
6	Number of sectors per track	No
7-9	Reserved	No
10-19	Serial Number	Optional
20	Buffer Type	Optional
21	Buffer Size	Optional
22	ECC bytes available	No
23-26	Firmware revision	Mandatory
27-46	Model Number	Mandatory
47	Multiple Sector Command, Sector Count	No
48	Double Word I/O (<i>shall</i> be 00h for CD-ROM)	No
49	Capabilities: LBA bit <i>shall</i> be supported; DMA, IORDY bits are optional.	Mandatory
50	Reserved	No
51	PIO Cycle Timing	Mandatory
52	DMA Cycle Timing	Mandatory
53	Validity of words 54-58 and 64-70 in this table	Mandatory
54 - 56	Current Cylinder/Heads/Sectors	No
57-58	Current Capacity	No
59	Reserved	No
60-61	User Addressable Sectors	No
62	Singleword DMA mode	Mandatory
63	Multiword DMA mode	Mandatory
64	Enhanced PIO mode	Mandatory

Table 12 - Identify Drive, Fields Supported by CD-ROM

Word	Description	Used
65	Blind PIO minimum cycle time	Mandatory
66	Recommended Multi Word DMA Transfer Cycle Time	Optional
67	Minimum PIO Transfer Cycle Time without Flow Control	Optional
68	Minimum PIO Transfer Cycle Time with IORDY Flow Control	Optional
69 - 70	Reserved (for advanced PIO support)	No
71 - 127	Reserved	No
128 - 159	Vendor Unique	No
160 - 255	Reserved	No

“Optional” Identify Drive words, which are not supported, *shall* be set to zero.

The ATAPI Identify Device command *shall not* delay the transfer of the Identify Drive data by more than 200 ms after receipt of the command.

8.1.7.1 General Configuration Word (0)

Table 13 - Identify Drive Data - General Configuration (Word 0)

Bit Byte	7/15	6/14	5/13	4/12	3/11	2/10	1/9	0/8
0	Removable	CMD DRQ Type		Reserved		CMD Packet Size		
1	Protocol Type		Reserved	Device Type				

Bits 15-14 Protocol Type

This field indicates the protocol in use by the device.

0Xb = ATA
10b = ATAPI
11b = Reserved

Bit 13 Reserved

This is reserved for future enhancement

Bits 12-8 Device Type

This field indicates the device type.

The peripheral types are described in Table 31, “Peripheral Drive Types” on page 68.

Bit 7 Removable

Indicates that the device has removable media.

Bits 6-5 CMD DRQ Type

This field indicates the command packet DRQ type used by this device.

00b = Microprocessor DRQ:

ATAPI devices reporting Microprocessor DRQ assertion *shall* assert DRQ within 3ms of receiving the A0h ATAPI Packet Command.

Implementer’s Note: Devices reporting Microprocessor DRQ require the device driver to poll for up to 3ms or accept the granularity of an available timer tick. These issues may result in undesirable system delays when used with multi-threaded OS drivers.

01b = Interrupt DRQ:

ATAPI devices reporting Interrupt DRQ assertion *shall* assert INTRQ in conjunction with the assertion of the command packet DRQ. These

devices *shall* assert DRQ within 10ms of receiving the A0h ATAPI Packet Command.

10b = Accelerated DRQ:
ATAPI devices reporting Accelerated DRQ assertion *shall* assert DRQ within 50us of receiving the A0h ATAPI Packet Command.

11b = Reserved for future use.

Bits 4-2 Reserved

This field is unique for each protocol and is reserved for future use.

Bits 1-0 Command Packet Size

This field indicates the size of the command packets used by this device.
00b = 12 bytes (ALL CD-ROM)
01b = 16 bytes (Reserved for SAM Compliant Devices)
1Xb = Reserved for future use.

8.1.7.2 Serial Number (Words 10 - 19)

This optional field *shall* contain the drive's serial number formatted as right-justified ASCII, padded with spaces (20h). If the field is not supported then it *shall* be filled with spaces.

8.1.7.3 Buffer Type (Word 20)

The contents of the field are determined by the manufacturer. These codes are not typically used by ATAPI devices, however, they may be useful for diagnostic programs which perform initialization routines.

8.1.7.4 Buffer Size (Word 21)

The contents of this field indicate the size of the buffer used for host transfers and caching by the device.

8.1.7.5 Firmware Revision (Words 23-26)

The contents of this field are vendor-specific, left-justified, and padded with spaces.

8.1.7.6 Model Number (Words 27 - 46)

The contents of this field are vendor-specific, left-justified, and padded with spaces.

8.1.7.7 Capabilities Word (Word 49)

Table 14 - Identify Drive Data - Capabilities Word (49)

Bit Byte	7/15	6/14	5/13	4/12	3/11	2/10	1/9	0/8
0	Vendor Unique							
1	Reserved	Reserved for Future ATAPI Standard	Reserved for Future ATAPI Standard	Reserved for Pseudo DMA Support	IORDY Supported	IORDY can be disabled	LBA Supported	DMA Supported

Bit 8 DMA Supported

This bit indicates that the Device supports the DMA mode of data transfer.

Bit 9	LBA Supported	Indicates that the Device supports the LBA form of addressing. The ATAPI Devices <i>shall</i> set this bit to one.
Bit 10	IORDY can be disabled	Is used to indicate a device's ability to enable or disable the use of IORDY. If this bit is set to one, then the device supports the disabling of IORDY.
Bit 11	IORDY Supported	This is used to help determine whether a device supports IORDY. If this bit is set to one, then the device supports IORDY operation. If this bit is zero then the device may support IORDY (this ensures backward compatibility.)
Bit 13	ATAPI Reserved	Reserved for a Future ATAPI enhancement.
Bit 14	ATAPI Reserved	Reserved for a Future ATAPI enhancement.

8.1.7.8 PIO Data Transfer Cycle Timing (Word 51)

The PIO transfer timing for each ATA device falls into categories which have unique parametric timing specifications. To determine the proper device timing category, compare the contents of this field with the Cycle Time specified in Figure 6 of the ATA document in Appendix B. The value returned in Bits 15-8 *shall* fall into one of the categories specified, and if it does not, then Mode 0 *shall* be used to serve as the default timing.

8.1.7.9 DMA Data Transfer Cycle Timing (Word 52)

The DMA transfer timing for each ATA device falls into categories which have unique parametric timing specifications. To determine the proper device timing category, compare the contents of this field with the Cycle Time specified in Figures 8 and 9 of the ATA document in Appendix B. The value returned in Bits 15-8 *shall* fall into one of the categories specified, and if it does not, then Mode 0 *shall* be used to serve as the default timing.

8.1.7.10 Field Validity (Word 53)

- Bit 0 When = 1, this bit guarantees that the fields contained in words 54-58 are valid.
- Bit 1 When = 1, this bit guarantees that the fields contained in words 64-70 are valid.

8.1.7.11 Single Word DMA Transfer (Word 62)

The low order byte identifies by bit all of the modes which are supported, e.g., if Mode 0 is supported, bit 0 is set. The high order byte contains a single bit set to indicate which mode is active, e.g., if Word 0 is active, bit8 is set.

8.1.7.12 Multi Word DMA Transfer (Word 63)

The low order byte identifies by bit all of the modes which are supported, e.g., if Mode 0 is supported, bit 0 is set. The high order byte contains a single bit set to indicate which mode is active, e.g., if Word 0 is active, bit8 is set.

8.1.7.13 Enhanced PIO Mode (Word 64)

Bits 7 through 0 of the word 64 of the Identify Drive parameter information is defined as the Advanced PIO Data Transfer Supported Field. This field is bit significant. Any number of bits may be set in this field by the device to indicate which Advanced PIO Modes that it is capable of supporting. Of these bits, bits 7 through 1 are reserved for future advanced PIO modes. Bit 0, if set, indicates that the device supports PIO Mode 3.

8.1.7.14 Minimum Multi-word DMA Transfer Cycle Time per Word (Word 65)

Word 65 of the parameter information of the IDENTIFY DRIVE command is defined as the Minimum Multi-word DMA Transfer Cycle Time Per Word. This field defines, in nanoseconds, the minimum cycle time that the device can support when performing Multi-word DMA transfers on a per word basis.

Any device which supports Multi-word DMA Mode 1 or above *shall* support this field, and the value in word 65 *shall* not be less than 150.

If the device does not support this field, the device *shall* return a value of zero in this field.

8.1.7.15 Manufacturer's Recommended Multi-word DMA Transfer Cycle Time (Word 66)

Word 66 of the parameter information of the IDENTIFY DRIVE command is defined as the Manufacturer's Recommended Multi-word DMA Transfer Cycle Time. This field defines, in nanoseconds, the minimum cycle time per word during a single sector host transfer while performing a multiple sector READ DMA or WRITE DMA commands over all locations on the media under nominal conditions. A cycle time less than this value may cause DMARQ to be deasserted at a rate which may reduce throughput without data corruption.

Any device which supports Multi-word DMA Mode 1 or above *shall* support this field, and the value in word 66 *shall not* be less than the value in word 65.

If the device does not support this field, the device *shall* return a value of zero in this field.

8.1.7.16 Minimum PIO Transfer Cycle Time Without Flow Control (Word 67)

Word 67 of the parameter information of the IDENTIFY DRIVE command is defined as the Minimum PIO Transfer Without Flow Control Cycle Time. This field defines, in nanoseconds, the minimum cycle time that, if used by the host, the device guarantees data integrity during the transfer without utilization of flow control.

Any device which supports PIO Mode 3 or above *shall* support this field, and the value in word 67 *shall not* be less than 180.

If the device does not support this field, the device *shall* return a value of zero in this field.

8.1.7.17 Minimum PIO Transfer Cycle Time with IORDY Flow Control (Word 68)

Word 68 of the parameter information of the IDENTIFY DRIVE command is defined as the Minimum PIO Transfer With IORDY Flow Control Cycle Time. This field defines, in nanoseconds, the minimum cycle time that the device can support while performing data transfers while utilizing IORDY flow control.

Any device which supports PIO Mode 3 or above *shall* support this field, and the value in word 68 *shall* not be less than 180. If the device does not support this field, the device *shall* return a value of zero in this field.

8.1.8 Set Features

The Set Features command is used to set some interface timing and protocol modes. These modes are set at Post by many BIOSes. The contents of the ATAPI Features Register indicates the function to be performed.

Table 15 - Contents of the Feature Register for Set Features Command

Bit Byte	7	6	5	4	3	2	1	0
0	Set (1)/ Clear (0) Feature	Feature Number						

Table 16 - Set Feature Register Definitions

Feature Number	Set Feature Commands	Supported
01h	Enable 8-bit data transfers	No
02h	Enable write cache	No
03h	Set transfer mode based on value in sector count register	Mandatory
33h	Disable retry	No
44h	Vendor unique length of ECC on read long/write long commands	No
54h	Set cache segments to sector count register value	No
5Dh	Enable Shared Interrupts	Optional
55h	Disable read look-ahead feature	No
66h	Disable reverting to power on defaults	Mandatory
77h	Disable ECC	No
81h	Disable 8-bit data transfers	No
82h	Disable write cache	No
88h	Enable ECC	No
99h	Enable retries	No
AAh	Enable read look-ahead feature	No
ABh	Set maximum prefetch using sector count register value	No
BBh	4 bytes of ECC apply on read long/write long commands	No
CCh	Enable reverting to power on defaults	Mandatory
DDh	Disable Shared Interrupts	Optional

If the value in the register is not supported or is invalid, the drive posts an Aborted Command error. At power on, or after a hardware reset, the default mode is the same as that represented by values greater than 80h.

8.1.8.1 Set Transfer Mode (03h)

A host can choose the transfer mechanism by Set Transfer Mode and specifying a value in the Sector Count Register. The upper 5 bits define the type of transfer and the low order 3 bits encode the mode value. Since both PIO and DMA settings can be active simultaneously, the Device *shall* maintain independent transfer mode settings for both PIO and DMA.

Table 17 - Feature Number Description for Set Feature Command

Feature Number		Default Setting	
03h	Data Transfer Mode. Mode contained in Sector Count Register.		PIO & DMA Mode 0
	Value in Sector Count Register	Definition	
	00000 00x	PIO Default Transfer Mode	
	00001 xxx	PIO Flow Control Transfer mode x	
	00010 xxx	Single Word DMA mode x	
	00011 xxx	Reserved (For Pseudo DMA mode)	

If a device which supports this specification receives a Set Feature command with a Set Transfer Mode parameter and a Sector count Register value of 00000 000, it *shall* set its default PIO transfer mode.

If a device which supports this specification receives a Set Feature command with a Set Transfer Mode parameter and a Sector Count Register value of 00000 001 and the device supports disabling of IORDY, then the device *shall* set its default PIO transfer mode and disable IORDY.

8.1.8.2 Disable Reverting to Power On Defaults (66h)

A setting of 66h allows settings of greater than 80h which may have been modified since power on to remain at the same setting after a software reset. At power on, or after a hardware reset, the default mode is the same as that represented by values greater than 80h.

8.1.8.3 Enable Reverting to Power On Defaults (CCh)

A setting of CCh will cause the Device to revert back to the default for settings of greater than 80h, which may have been modified since power on, after a software reset.

8.1.8.4 Disable Shared Interrupts (DDh)

A setting of DDh will disable shared interrupts. Devices supporting Enable Shared Interrupts *shall* support this command.

8.1.8.5 Enable Shared Interrupts (5Dh)

A setting of 5Dh allows the selection of shared interrupts. Devices supporting this command *shall* assert interrupts via a low true open collector driver.

8.1.9 Sleep

This command is the only way to cause the drive to enter Sleep Mode. The drive is spun down, and when it is stopped, BSY is cleared, an interrupt is generated, and the interface becomes inactive.

The only way to recover from Sleep mode is with a software reset or a hardware reset.

NOTE: The use of hardware reset to recover from Sleep mode may be incompatible with continued operation of the host system.

A drive *shall* not power on in Sleep Mode nor remain in Sleep Mode following a reset sequence. If the drive is already spun down, the spin down sequence is not executed.

8.1.10 Standby Immediate

This command causes the drive to enter the Standby Mode. The drive may return the interrupt before the transition to Standby Mode is completed.

If the drive has already spun down, the spin down sequence is not executed.

For Standby immediate the drive may return the interrupt before the transition to Standby Mode is completed.

Preliminary Draft
for Review Only

Intentionally Left Blank

Preliminary Draft
for Review Only

9.0 CD-ROM Packet Commands

9.1 Packet Command Implementation Requirements

The first byte of all ATAPI CD-ROM Drive Command Packets *shall* contain an operation code as defined in this Specification. ATAPI CD-ROM Drives *shall* implement all commands with mandatory operation codes.

9.1.1 Reserved

Reserved bits, fields, bytes, and code values are set aside for future standardization. Their use and interpretation may be specified by future extensions to this or other standards. A reserved bit, field, or byte *shall* be set to zero, or in accordance with a future extension to this standard. The recipient *shall* not check reserved fields.

9.1.2 Operation Code Types

The operation code types are defined in Table 18 - below.

Table 18 - Operation Code Types

Operation Code Type	Description
M	Mandatory - Commands so designated <i>shall</i> be implemented in order to meet the minimum requirement of this Specification.
O	Optional - Commands so designated, if implemented, <i>shall</i> be implemented as defined in this Specification.
V	Vendor-specific - Operation codes so designated are available for vendor defined commands. See the vendor specifications where compatibility is desired.
R	Reserved - Operation codes so designated <i>shall not</i> be used. They are reserved for future extensions to this Specification.

9.2 ATAPI Command Packet Description

An ATAPI command is communicated by sending a Command Packet to the ATAPI CD-ROM Drive. For several commands, the Command Packet is accompanied by a list of parameters sent upon receiving an interrupt following the Command Packet being sent. See the specific commands for detailed information.

The Command Packet always has an operation code as its first byte.

For all commands, if there is an invalid parameter in the Command Packet, then the ATAPI Device *shall* abort the command without altering the medium.

Table 19 - Typical Command Packet for Most Commands

Byte	Bit	7	6	5	4	3	2	1	0
0		Operation Code							
1		Reserved				Reserved			
2	(MSB)	Logical Block Address (if required)							
3									
4									
5									
6		Reserved							
7 - 8	(MSB)	Transfer Length (if required) or Parameter List Length (if required) or Allocation Length (if required)(LSB)							
9		Reserved							
10		Reserved							
11		Reserved							

Table 20 - Typical Command Packet for Some Extended Commands

Byte	Bit	7	6	5	4	3	2	1	0
0		Operation Code							
1		Reserved				Reserved			
2	(MSB)	Logical Block Address (if required)							
3									
4									
5									
6	(MSB)	Transfer Length (if required) or Parameter List Length (if required) or Allocation Length (if required)							
7									
8									
9									
10		Reserved							
11		Reserved							

9.2.1 Operation Code

The operation code of the Command Packet has a group code field and a command code field. The three-bit group code field provides for eight groups of command codes. The five-bit command code field provides for thirty-two command codes in each group. Thus, a total of 256 possible operation codes exist. Operation codes are defined in the subsequent sections.

Table 21 - Operation Code

Bit	7	6	5	4	3	2	1	0
	Group Code			Command Code				

Note that the Group / Command code fields have been kept for backward compatibility and are not used by ATAPI.

9.2.2 Logical Block Address

The logical block address *shall* begin with block zero and be contiguous up to the last logical block.

9.2.3 Transfer Length

The Transfer Length Field specifies the amount of data to be transferred, usually the number of blocks. For several commands the transfer length indicates the requested number of bytes to be sent as defined in the command description. For these commands the Transfer Length Field may be identified by a different name. See the following descriptions and the individual command descriptions for further information.

In commands that use multiple bytes for the transfer length, a transfer length of zero indicates that no data transfer *shall* take place. A value of one or greater indicates the number of blocks that *shall* be transferred.

9.2.4 Parameter List Length

The Parameter List Length is used to specify the number of bytes to be sent to the Drive. This field is typically used in Command Packets for parameters that are sent to a Drive (e.g. mode parameters, diagnostic parameters, etc.). A parameter length of zero indicates that no data *shall* be transferred. This condition *shall* not be considered as an error.

9.2.5 Allocation Length

The Allocation Length Field specifies the maximum number of bytes that a Host Computer has allocated for returned data. An allocation length of zero indicates that no data *shall* be transferred. This condition *shall* not be considered as an error. The Drive *shall* terminate the data transfer when allocation length bytes have been transferred or when all available data have been transferred to the Host Computer, whichever is less. The allocation length is used to limit the maximum amount of data (e.g. sense data, mode data, etc.) returned to a Host.

9.3 Status

A Status byte *shall* be sent from the Drive to the Host Computer at the completion of each command unless the command is terminated by one of the following events:

1. a hard reset condition;
2. an unexpected event

Status is normally presented at the end of a command, but in some cases may occur prior to transferring the Command Packet.

For a description of the Status Byte see "Figure 6 - ATAPI Status Register (ATA Status Register)" on page 40.

9.4 Immediate Command Processing Considerations

Immediate commands are a class of commands which return completion status to the host system before they are finished executing the command. The purpose of immediate commands is to allow the host to execute more than one command at a time on the same IDE cable. An example of a typical overlapped cd-rom command execution would be to Play audio while accessing data from a disk drive on the same cable. In this example the host system would issue a Play Audio command. The ATAPI CD-Rom device would accept the command, and if valid return status to the host immediately. The host system is now free to issue additional commands to any other device at the same IDE port address including the ATAPI device executing the immediate command.

ATAPI devices use the DSC bit to indicate the completion status of immediate commands. No INTRQ is issued by these device when the DSC bit is set, so it the responsibility of the ATAPI driver to poll this bit to determine the completion status of the immediate command. See also "5.6 Overlapped Command Operation" on page 23.

9.5 Command Processing Considerations and Exception Conditions

The following sections describe some exception conditions and errors associated with command processing and the sequencing of commands.

9.5.1 Parameter Rounding

Certain parameters sent to an ATAPI CD-ROM Drive with various commands contain a range of values. ATAPI CD-ROM Drives may choose to implement only selected values from this range. When the ATAPI CD-ROM Drive receives a value that it does not support, it either rejects the command (CHECK CONDITION status with ILLEGAL REQUEST sense key) or it rounds the value received to a supported value. The ATAPI CD-ROM Drive *shall* reject unsupported values unless rounding is permitted in the description of the parameter.

Rounding of parameter values, when permitted¹, *shall* be performed as follows - An ATAPI CD-ROM Drive that receives a parameter value that is not an exact supported value *shall* adjust the value to one that it supports and *shall* return CHECK CONDITION status with a sense key of RECOVERED ERROR. The additional sense code *shall* be set to ROUNDED PARAMETER. The Host Computer is responsible for issuing an appropriate command to learn what value the ATAPI CD-ROM Drive has selected.

9.6 Unit Attention Condition

The ATAPI CD-ROM Drive *shall* generate a unit attention whenever the ATAPI CD-ROM Drive has been reset by a hard reset condition, or by a power-on reset. The ATAPI CD-ROM Drive *shall* also generate a unit attention condition whenever one of the following events occurs:

1. A removable medium may have been changed;
2. The version or level of microcode has been changed;
3. INQUIRY or Packet Identify Drive Data has been changed;

1. Generally, the ATAPI CD-ROM Drive should adjust maximum-value fields down to the next lower supported value than the one specified by the Host Computer. Minimum-value fields should be rounded up to the next higher supported value than the one specified by the Host Computer. In some cases, the type of rounding (up or down) is explicitly specified in the description of the parameter.

4. The mode parameters in effect for the Host Computer have been restored from non-volatile memory;
5. Any other event occurs that requires the attention of the Host Computer.

The ATAPI CD-ROM Drive may queue unit attention conditions. After the first unit attention condition is cleared, another unit attention condition may exist (e.g. a power on condition followed by a microcode change condition).

The unit attention condition *shall* persist, until the Host Computer clears the condition as described in the following paragraphs.

If an INQUIRY command is received from an Host Computer with a pending unit attention condition, the ATAPI CD-ROM Drive *shall* perform the INQUIRY command and *shall not* clear the unit attention condition.

If a REQUEST SENSE command is received from a Host Computer with a pending unit attention condition, then the ATAPI CD-ROM Drive *shall* either:

1. report any pending sense data and preserve the unit attention condition, or,
2. report the unit attention condition, may discard any pending sense data, and clear the unit attention condition.

If an Host Computer issues a command other than INQUIRY or REQUEST SENSE while a unit attention condition exists for that Host, the ATAPI CD-ROM Drive *shall not* perform the command and *shall* report CHECK CONDITION status unless a higher priority status as defined by the ATAPI CD-ROM Drive is also pending (e.g. BUSY).

9.7 Commands and Parameters

The ATAPI CD-ROM commands are derived from the SCSI CD-ROM command set.

With the exception of the CD-ROM Track/Index and MSF addressing techniques, the interface uses logical rather than physical addressing for all data blocks. Each Device may be interrogated to determine how many blocks it contains.

Commands are classified as mandatory, optional, or vendor-specific. ATAPI CD-ROM drives are required to implement all mandatory commands and may implement other commands as well. ATAPI CD-ROM Drives contain commands that facilitate the writing of self-configuring software drivers that can discover all necessary attributes without prior knowledge of specific peripheral characteristics (such as storage capacity).

9.8 ATAPI Packet Commands for CD-ROM Devices

Table 22 - Packet Commands Supported by CD-ROM Drives

Command Description	Opcode	Type	Reference
AUDIO SCAN	BAh	O	section 9.8.1 on page 71
INQUIRY	12h	M	section 9.8.2 on page 75
MODE SELECT (10)	55h	M	section 9.8.3 on page 83
MODE SENSE (10)	5Ah	M	section 9.8.4 on page 85
PAUSE/RESUME	4Bh	O*	section 9.8.6 on page 103
PLAY AUDIO (10)	45h	O*	section 9.8.7 on page 105
PLAY AUDIO (12)	A5h	O*	section 9.8.8 on page 108
PLAY AUDIO MSF	47h	O*	section 9.8.9 on page 109
PLAY TRACK RELATIVE(10)	49h	O*	section 9.8.10 on page 111
PLAY TRACK RELATIVE(12)	A9h	O*	section 9.8.11 on page 113
Reserved for - PLAY CD-ROM XA (12)	BDh	R**	section B.1.1 on page 179
Reserved for SEND CD-ROM XA ADPCM DATA	BCh	R**	section B.1.2 on page 181
PREVENT/ALLOW MEDIUM REMOVAL	1Eh	M	section 9.8.12 on page 115
READ (10)	28h	M	section 9.8.13 on page 117
READ (12)	A8h	O	section 9.8.13 on page 117
READ CD-ROM CAPACITY	25h	M	section 9.8.15 on page 121
READ CD	BEh	M	section 9.8.16 on page 123
READ CD MSF	B9h	M	section 9.8.17 on page 133
READ HEADER	44h	M	section 9.8.18 on page 135
READ SUB-CHANNEL	42h	M	section 9.8.19 on page 137
READ TOC	43h	M	section 9.8.20 on page 145
REQUEST SENSE	03h	M	section 9.8.21 on page 153
REZERO UNIT	01h	O	section 9.8.22 on page 161
SEEK	2Bh	M	section 9.8.23 on page 163
SET CD-ROM SPEED	BBh	O	section 9.8.24 on page 165
STOP PLAY / SCAN	4Eh	M	section 9.8.25 on page 167
START STOP UNIT	1Bh	M	section 9.8.26 on page 169
TEST UNIT READY	00h	M	section 9.8.27 on page 171
Reserved for future use	B4h		
Reserved for future use	BFh		

Key: M = command implementation is mandatory.

O = command implementation is optional.

* = indicates a PLAY AUDIO command. If any of the PLAY AUDIO commands (indicated by an * in the type column) are implemented, all the PLAY AUDIO commands *shall* be implemented by the ATAPI CD-ROM Drive.

** = indicates a CD-ROM XA command. If any of the CD-ROM XA commands (indicated by an ** in the type column) are implemented, all the CD-ROM XA commands *shall* be implemented by the ATAPI CD-ROM Drive.

9.8.1 AUDIO SCAN Command

The AUDIO SCAN command requests a fast-forward or fast-reverse audio scan operation starting from the Scan Starting Address. The command *shall* scan all the way to the end of the media (last audio track).

This command responds with immediate status, allowing overlapped commands. This command *shall* set the DSC bit upon command completion. See also "9.4 Immediate Command Processing Considerations" on page 68.

A Direction (DIRECT) bit of zero indicates a fast-forward. A DIRECT bit of one indicates a fast-reversed operation.

The Scan Starting Address specifies the address at which the Audio Fast Scan *shall* begin. The Type Field determines the interpretation of the address.

Like the Audio Play Command, the AUDIO SCAN Command *shall* terminate the scan at the last audio track or upon receipt of the STOP PLAY / SCAN Command. Upon receipt of the STOP PLAY / SCAN Command the Device *shall* set the current address to the last address output during the AUDIO SCAN Command. Subsequent Audio Play Commands *shall* cause the device to begin playing at the location last output by the AUDIO SCAN Command. Therefore, the host must issue an AUDIO PLAY Command immediately following a STOP PLAY / SCAN Command to resume playing audio at normal speed. See "Figure 17 - Stop Play/Play Audio/Audio Scan/Pause/Resume Sequencing" on page 168 for additional information.

Table 23 - AUDIO SCAN Command

Bit Byte	7	6	5	4	3	2	1	0	
0	Operation code (BAh)								
1	Reserved			DIRECT	Reserved				
2	Scan Starting Address Field								
3									
4									
5									
6	Reserved								
7									
8									
9	Type			Reserved					
10	Reserved								
11	Reserved								

Bits 7-6 Type This field specifies the "Type" of address contained in the Scan Starting Address Field.

- | | | |
|---|---|------------------------------|
| 0 | 0 | Logical Block Address format |
| 0 | 1 | AMIN, ASEC and AFRAME format |
| 1 | 0 | Track Number (TNO) format |
| 1 | 1 | Reserved |

See "9.8.7.1 Play Audio with Overlapped Packet Commands" on page 106 for information on overlapped commands during an Audio Scan operation.

Table 24 - Scan Starting Address in Logical Block Format

Bit Byte	7	6	5	4	3	2	1	0
2	Starting Logical Block Address							
3								
4								
5								

Table 25 - Scan Starting Address in AMIN, ASEC and AFRAME Format

Bit Byte	7	6	5	4	3	2	1	0
2	Reserved							
3	CD-absolute time (AMIN)							
4	CD-absolute time (ASEC)							
5	CD-absolute time (AFRAME)							

The AMIN, ASEC and AFRAME fields specifies the relative running time from the beginning of the disc. The AMIN field has a range of 00 to 99d (63h). The ASEC ranges from 00 to 59d (3Bh). The AFRAME field has a range of 00 to 74d (4Ah). All MSF fields *shall* be Binary.

Table 26 - Scan Starting Address in Track Number (TNO) Format

Bit Byte	7	6	5	4	3	2	1	0
2	Reserved							
3	Reserved							
4	Reserved							
5	Track Number (TNO)							

The Track Number field specifies the track in binary notation at which the scan operation will begin. This field has a range of 01h to 63h.

Table 27 - Recommended Sense Key, ASC and ASCQ for Audio Scan Command Errors

Sense Key	ASC	ASCQ	Description of Error
05	20		INVALID COMMAND OPERATION CODE
05	24		INVALID FIELD IN COMMAND PACKET
06	28		NOT READY TO READY TRANSITION
06	29		POWER ON, RESET OR BUS DEVICE RESET OCCURRED
02	04	00	LOGICAL UNIT NOT READY - CAUSE NOT REPORTABLE
02	04	01	LOGICAL UNIT NOT READY - IN PROGRESS OF BECOMING READY
02	04	02	LOGICAL UNIT NOT READY - INITIALIZING COMMAND REQUIRED
02	04	03	LOGICAL UNIT NOT READY - MANUAL INTERVENTION REQUIRED
02	3A		MEDIUM NOT PRESENT
03	02		NO SEEK COMPLETE
02	06	00	NO REFERENCE POSITION FOUND (media may be upside down)
02	30	00	INCOMPATIBLE MEDIUM INSTALLED
02	30	01	CANNOT READ MEDIUM - UNKNOWN FORMAT
02	30	02	CANNOT READ MEDIUM - INCOMPATIBLE FORMAT
05	21		LOGICAL BLOCK ADDRESS OUT OF RANGE
05	54		ILLEGAL MODE FOR THIS TRACK

Preliminary Draft
for Review Only

Intentionally Left Blank

9.8.2 INQUIRY Command

The INQUIRY command requests that information regarding parameters of the ATAPI CD-ROM Drive be sent to the Host Computer. An option allows the Host Computer to request additional information about the ATAPI CD-ROM Drive.

Table 28 - INQUIRY Command

Bit Byte	7	6	5	4	3	2	1	0
0	Operation code (12h)							
1	Reserved							EVPD
2	Page Code							
3	Reserved							
4	Allocation Length							
5	Reserved							
6	Reserved							
7	Reserved							
8	Reserved							
9	Reserved							
10	Reserved							
11	Reserved							

An Enable Vital Product Data (EVPD) bit of one specifies that the ATAPI CD-ROM Drive *shall* return the optional vital product data specified by the page code field. If the ATAPI CD-ROM Drive does not support vital product data and this bit is set to one, the ATAPI CD-ROM Drive *shall* return CHECK CONDITION status with the sense key set to ILLEGAL REQUEST and an additional sense code of INVALID FIELD IN COMMAND PACKET.

An EVPD bit of zero specifies that the ATAPI CD-ROM Drive *shall* return the standard INQUIRY data. If EVPD is zero and the Page Code field is not zero, the ATAPI CD-ROM Drive *shall* return CHECK CONDITION status with the sense key set to ILLEGAL REQUEST and an additional sense code of INVALID FIELD IN COMMAND PACKET.

The Page Code field specifies which page of vital product data information the ATAPI CD-ROM Drive *shall* return to this Host.

The INQUIRY command *shall* return CHECK CONDITION status only when the ATAPI CD-ROM Drive cannot return the requested INQUIRY data. The INQUIRY data should be returned even though the peripheral device may not be ready for other commands.

If an INQUIRY command is received with a pending unit attention condition (i.e. before the ATAPI CD-ROM Drive reports CHECK CONDITION status), the ATAPI CD-ROM Drive *shall* perform the INQUIRY command and *shall not* clear the unit attention condition.

9.8.2.1 Standard INQUIRY Data

The standard INQUIRY data contains 36 required bytes, followed by a variable number of vendor-specific parameters. Bytes 56 through 95, if returned, are reserved for future standardization.

Table 29 - INQUIRY Data Format

Bit Byte	7	6	5	4	3	2	1	0
0	Reserved			Peripheral Device Type				
1	RMB	Reserved						
2	ISO Version		ECMA Version			ANSI Version (00)		
3	Reserved				Response Data Format			
4	Additional Length (n-4)							
5	Reserved							
6	Reserved							
7	Reserved							
8	Vendor Identification							
15								
16	Product Identification							
31								
32	Product Revision Level							
35								
36	Vendor-specific							
55								
56	Reserved							
95								
Vendor Specific Parameters								
96								
n								

The device-type fields identifies the device. It is defined in "Table 30 - Peripheral Device Types" on page 76.

9.8.2.2 Using the INQUIRY Command

The INQUIRY command may be used by a Host Computer to determine the configuration of the ATAPI CD-ROM Drive. ATAPI CD-ROM Drives respond with information that includes their type and Specification level and may include the vendor's identification, model number and other useful information.

Table 30 - Peripheral Device Types

Code	Description
00h	Direct-access device (e.g. magnetic disk)
01h - 04h	Reserved
05h	CD-ROM device
06h	Reserved
07h	Optical memory device (e.g. some optical disks)
08h - 1Eh	Reserved
1Fh	Unknown or no device type

The Peripheral Device Type *shall* be set to 05h to indicate a CD-ROM Device.

A Removable Medium Bit (RMB) of zero indicates that the medium is not removable. A RMB bit of one indicates that the medium is removable. CD-ROM Devices should always report “Removable”.

The usage of non-zero code values in the ISO version and ECMA version fields are defined by the International Organization for Standardization and the European Computer Manufacturers Association, respectively.

The ANSI-approved version field must contain a zero to comply with this version of the Specification.

A response data format value of 01h indicates that the data *shall* be in the format specified in this Specification. Response data format values greater than one are reserved.

The Additional Length field *shall* specify the length in bytes of the parameters. If the allocation length of the Command Packet is too small to transfer all of the parameters, the additional length *shall* not be adjusted to reflect the truncation.

ASCII data fields *shall* contain only graphic codes (i.e. code values 20h through 7Eh). Left-aligned fields *shall* place any unused bytes at the end of the field (highest offset) and the unused bytes *shall* be filled with space characters (20h). Right-aligned fields *shall* place any unused bytes at the start of the field (lowest offset) and the unused bytes *shall* be filled with space characters (20h).

The Vendor Identification field contains 8 bytes of ASCII data identifying the vendor of the product¹. The data *shall* be left aligned within this field.

The Product Identification field contains 16 bytes of ASCII data as defined by the vendor. The data *shall* be left-aligned within this field.

The Product Revision Level field contains 4 bytes of ASCII data as defined by the vendor. The data *shall* be left-aligned within this field.

9.8.2.3 Vital Product Data

Implementation of vital product data is optional. The information returned consists of configuration data (e.g. vendor identification, product identification, model, serial number), manufacturing data (e.g. plant and date of manufacture), field replaceable unit data and other vendor-specific or device-specific data.

The Host Computer requests the vital product data information by setting the EVPD bit to one and specifying the page code of the desired vital product data. If the ATAPI CD-ROM Drive does not implement the requested page, it *shall* return CHECK CONDITION status. The sense key *shall* be set to ILLEGAL REQUEST and the additional sense code *shall* be set to INVALID FIELD IN COMMAND PACKET.

This Specification does not define the location or method of storing the vital product data. The retrieval of the data may require completion of initialization operations within the device that may induce delays before the data is available to the Host Computer. Time-critical requirements are an implementation consideration and are not addressed in this Specification.

9.8.2.4 Vital Product Data Parameters

This section describes the optional vital product data page structure and the vital product data pages. The vital product data may include vendor identification, product identification, unit serial numbers, device operating definitions, manufac-

1. It is intended that this field provide a unique vendor identification of the manufacturer of the ATAPI CD-ROM Drive. In the absence of a formal registration procedure, X3T9.2 maintains a list of vendor identification codes in use. Vendors are requested to voluntarily submit their identification codes to X3T9.2 to prevent duplication of codes.

turing data, field replaceable unit information, and other vendor-specific information. This Specification defines the structure of the vital product data, but not the contents.

Table 31 - Vital Product Data Page Codes

Page code	Description	Section
82h	ASCII Implemented Operating Definition Page	
01h - 7Fh	ASCII Information Page	
81h	Implemented Operating Definitions Page	
00h	Supported Vital Product Data Pages	
80h	Unit Serial Number Page	
83h - BFh	Reserved	
C0h - FFh	Vendor-specific	

9.8.2.4.1 ASCII Implemented Operating Definition Page

The ASCII Implemented Operation Definition Page contains operating definition description data for all operating definitions implemented by the ATAPI CD-ROM Drive. The contents of this data is not defined by this Specification.

Table 32 - ASCII Implemented Operating Definition

Bit Byte	7	6	5	4	3	2	1	0
0	Peripheral Qualifier			Peripheral Device Type				
1	Page Code (82h)							
2	Reserved							
3	Page Length							
4	ASCII Operating Definition Description Length (m-4)							
5	ASCII Operating Definition Description Data							
m	Vendor-specific Description Data							
m+1								
n								

The Peripheral Device Type field is defined in "Table 30 - Peripheral Device Types" on page 76.

The Page Length field specifies the length of the following page data. If the allocation length is less than the length of the data to be returned, the page length **shall not** be adjusted to reflect the truncation.

The ASCII Operating Definition Description Length field specifies the length in bytes of the ASCII operating definition description data that follows. If the allocation length is less than the length of data to be returned, the ASCII Operating Definition Description Length **shall not** be adjusted to reflect the truncation. A value of zero in this field indicates that no ASCII Operating Definition Description Data is available.

The ASCII Operating Definition Description Data field contains the ASCII operating definition description data for the ATAPI CD-ROM Drive. The data in this field **shall** be formatted in lines (or character strings). Each line **shall** contain only graphic codes (i.e. code values 20h through 7Eh) and **shall** be terminated with a NULL (00h) character.

9.8.2.4.2 ASCII Information Page

The ASCII Information Page returns information for the field replaceable unit code returned in the REQUEST SENSE data.

Table 33 - ASCII Information Page

Bit Byte	7	6	5	4	3	2	1	0
0	Peripheral Qualifier			Peripheral Device Type				
1	Page Code (01h - 7Fh)							
2	Reserved							
3	Page Length (n-3)							
4	ASCII Length (m-4)							
5	ASCII Information							
m	Vendor-specific Description Information							
m+1								
n								

The Peripheral Device Type field is defined in "Table 30 - Peripheral Device Types" on page 76.

The Page Code field contains the same value as in the page code field of the INQUIRY Command Packet and is associated with the field replaceable unit code returned by the REQUEST SENSE command.

The Page Length field specifies the length of the following page data. If the allocation length of the Command Packet is too small to transfer all of the page, the page length **shall not** be adjusted to reflect the truncation.

The ASCII Length field specifies the length in bytes of the ASCII information that follows. If the allocation length of the Command Packet is less than the length of the data to be returned, the ASCII length **shall not** be adjusted to reflect the truncation. A value of zero in this field indicates that no ASCII information is available for the specified page code.

The ASCII Information field contains ASCII information concerning the field replaceable unit identified by the page code. The data in this field **shall** be formatted in one or more lines (or character strings). Each line **shall** contain only graphic codes (i.e. code values 20h through 7Eh) and **shall** be terminated with a NULL (00h) character.

The contents of the Vendor-specific Information field is not defined in this Specification.

9.8.2.4.3 Supported Vital Product Data Pages

The Supported Vital Product Data Pages are shown in "Table 34 - Page Code 0: Supported VPD Pages" on page 80.

Table 34 - Page Code 0: Supported VPD Pages

Bit Byte	7	6	5	4	3	2	1	0
0	Peripheral Qualifier			Peripheral Device Type				
1	Page Code (00h)							
2	Reserved							
3	Page Length (n-3)							
4	Supported Page List							
n								

The Peripheral Device Type field is defined in "Table 30 - Peripheral Device Types" on page 76.

The Page Code field *shall* be set to the value of the page code field in the INQUIRY Command Packet.

The Page Length field specifies the length of the supported page list. If the allocation length of the Command Packet is too small to transfer all of the page, the page length *shall not* be adjusted to reflect the truncation.

The Supported Page List field *shall* contain a list of all vital product data page codes implemented for the ATAPI CD-ROM Drive in ascending order beginning with page code 00h.

9.8.2.4.4 Unit Serial Number Page

This page provides a product serial number for the ATAPI CD-ROM Drive.

Table 35 - Unit Serial Number Page

Bit Byte	7	6	5	4	3	2	1	0
0	Peripheral Qualifier			Peripheral Device Type				
1	Page Code (80h)							
2	Reserved							
3	Page Length (n-3)							
4	Product Serial Number							
n								

The Peripheral Device Type field is defined in "Table 30 - Peripheral Device Types" on page 76.

The Page Length Field specifies the length of the product serial number. If the allocation length of the Command Packet is too small to transfer all of the page, the page length *shall not* be adjusted to reflect the truncation.

The Product Serial Number field contains ASCII data that is vendor-specific. The least significant ASCII character of the serial number *shall* appear as the last byte of a successful data transfer. If the product serial number is not available, the ATAPI CD-ROM Drive *shall* return ASCII spaces (20h) in this field.

Table 36 - Recommended Sense Key, ASC and ASCQ for Inquiry Command Errors

Sense Key	ASC	ASCQ	Description of Error
05	20		INVALID COMMAND OPERATION CODE
05	24		INVALID FIELD IN COMMAND PACKET

Preliminary Draft
for Review Only

Preliminary Draft
for Review Only

Intentionally Left Blank

9.8.3 MODE SELECT Command

The MODE SELECT command provides a means for the Host Computer to specify medium, or peripheral device parameters to the ATAPI CD-ROM Drive. Host Computers *shall* issue MODE SENSE prior to each MODE SELECT to determine supported pages, page lengths, and other parameters.

Table 37 - Mode Select Command

Bit Byte	7	6	5	4	3	2	1	0
0	Operation code (55h)							
1	Reserved			1	Reserved			SP
2	Page Code							
3	Reserved							
4	Reserved							
5	Reserved							
6	Reserved							
7	Parameter List Length (MSB)							
8	Parameter List Length (LSB)							
9	Reserved							
10	Reserved							
11	Reserved							

A Save Pages (SP) bit of zero indicates the ATAPI CD-ROM Drive *shall* perform the specified MODE SELECT operation, and *shall not* save any pages. An SP bit of one indicates that the ATAPI CD-ROM Drive *shall* perform the specified MODE SELECT operation, and *shall* save to a non-volatile vendor-specific location all the savable pages. If an ATAPI CD-ROM Drive supports saved pages, it *shall* save only one copy of the page. The SP bit is optional, even when mode pages are supported by the ATAPI CD-ROM Drive. Pages that are saved are identified by the parameter savable bit that is returned in the page header by the MODE SENSE command. If the PS bit is set in the MODE SENSE data then the page *shall* be savable by issuing a MODE SELECT command with the SP bit set. If the ATAPI CD-ROM Drive does not implement saved pages and the SP bit is set to one, the command *shall* be terminated with CHECK CONDITION status. The sense key *shall* be set to ILLEGAL REQUEST, and the additional sense code set to INVALID FIELD IN COMMAND PACKET.

The Parameter List Length field specifies the length in bytes of the mode parameter list that *shall* be transferred from the Host Computer to the ATAPI CD-ROM Drive after the Command Packet is transferred. A parameter list length of zero indicates that no data *shall* be transferred. This condition *shall not* be considered as an error.

The ATAPI CD-ROM Drive *shall* terminate the command with CHECK CONDITION status if the parameter list length results in the truncation of any mode parameter header, or mode page. The sense key *shall* be set to ILLEGAL REQUEST, and the additional sense code *shall* be set to PARAMETER LIST LENGTH ERROR.

The mode parameter list for the MODE SELECT and MODE SENSE commands is defined in "9.8.5 Mode Select/Sense Parameters" on page 88.

The ATAPI CD-ROM Drive *shall* terminate the MODE SELECT command with CHECK CONDITION status, set the sense key to ILLEGAL REQUEST, set the additional sense code to INVALID FIELD IN PARAMETER LIST, and *shall not* change any mode parameters for the following conditions:

1. If the Host Computer sets any field that is reported as not changeable by the ATAPI CD-ROM Drive to a value other than its current value.

2. If the Host Computer sets any field in the mode parameter header to an unsupported value.
3. If an Host Computer sends a mode page with a page length not equal to the page length returned by the MODE SENSE command for that page.
4. If the Host Computer sends an unsupported value for a mode parameter and rounding is not implemented for that mode parameter.
5. If the Host Computer sets any reserved field in the mode parameter list to a non-zero value.

If the Host Computer sends a value for a mode parameter that is outside the range supported by the ATAPI CD-ROM Drive and rounding is implemented for that mode parameter, the ATAPI CD-ROM Drive may either:

1. round the parameter to an acceptable value and terminate the command;
2. terminate the command with CHECK CONDITION status, the sense key set to ILLEGAL REQUEST, and set the additional sense code to INVALID FIELD IN PARAMETER LIST.

An ATAPI CD-ROM Drive may alter any mode parameter in any mode page (even those reported as non-changeable) as a result of changes to other mode parameters¹.

The ATAPI CD-ROM Drive validates the non-changeable mode parameters against the current values that existed for those mode parameters prior to the MODE SELECT command.

Table 38 - Recommended Sense Key, ASC and ASCQ for Mode Select Command Errors

Sense Key	ASC	ASCQ	Description of Error
05	20		INVALID COMMAND OPERATION CODE
05	24		INVALID FIELD IN COMMAND PACKET
06	28		NOT READY TO READY TRANSITION
06	29		POWER ON, RESET OR BUS DEVICE RESET OCCURRED
06	2A		MODE PARAMETER CHANGED
05	26		INVALID FIELD IN PARAMETER LIST
05	00	11	AUDIO PLAY OPERATION IN PROCESS

1. If the current values calculated by the ATAPI CD-ROM Drive affect the Host Computer's operation, the Host Computer *shall* issue a MODE SENSE command after each MODE SELECT command.

9.8.4 MODE SENSE Command

The MODE SENSE command provides a means for an ATAPI CD-ROM Drive to report parameters to the Host Computer. It is a complementary command to the MODE SELECT command.

Table 39 - Mode Sense command

Bit Byte	7	6	5	4	3	2	1	0
0	Operation code (5Ah)							
1	Reserved			Reserved	Reserved	Reserved		
2	PC			Page Code				
3	Reserved							
4	Reserved							
5	Reserved							
6	Reserved							
7	Allocation Length (MSB)							
8	Allocation Length (LSB)							
9	Reserved							
10	Reserved							
11	Reserved							

The Page Control (PC) field defines the type of mode parameter values to be returned in the mode pages. See sections "9.8.4.1 Current Values" - "9.8.4.4 Saved Values" below.

Table 40 - Page Control Field

Code	Type of Parameter	Section
00b	Current values	9.8.4.1 on page 86
01b	Changeable values	9.8.4.2 on page 86
10b	Default values	9.8.4.3 on page 86
11b	Saved values	9.8.4.4 on page 86

NOTE The Page Control field only affects the mode parameters within the mode pages, however the PS bit, Page Code and Page Length fields **shall** return current values since they have no meaning when used with other types. The mode parameter header **shall** return current values. (see also "9.8.5 Mode Select/Sense Parameters" on page 88)

The Page Code specifies which mode page(s) to return¹. See "Table 43 - Mode Page Codes for CD-ROM" on page 88 for a description of the Mode pages.

A Host Computer may request any one or all of the supported mode pages from an ATAPI CD-ROM Drive. If a Host Computer issues a MODE SENSE command with a page code value not implemented by the ATAPI CD-ROM Drive, the ATAPI CD-ROM Drive **shall** return CHECK CONDITION status and **shall** set the sense key to ILLEGAL REQUEST and the additional sense code to INVALID FIELD IN COMMAND PACKET.

A Page Code of 3Fh indicates that all mode pages implemented by the ATAPI CD-ROM Drive **shall** be returned to the Host Computer. If the mode parameter list exceeds 65536 bytes for a MODE SENSE command, the ATAPI CD-ROM Drive **shall** return CHECK CONDITION status and the sense key **shall** be set to ILLEGAL REQUEST and the addition-

1. Mode pages **shall** be returned in ascending page code order except for mode page 00h.

al sense code set to INVALID FIELD IN COMMAND PACKET.

Mode page 00h, if implemented, *shall* be returned after all other mode pages.

9.8.4.1 Current Values

A PC field value of 0h requests that the ATAPI CD-ROM Drive return the current values of the mode parameters. The current values returned are:

1. the current values of the mode parameters established by last successful MODE SELECT command.
2. the saved values of the mode parameters if a MODE SELECT command has not successfully completed since the last power-on, hard RESET condition.
3. the default values of the mode parameters, if saved values, are not available or not supported.

9.8.4.2 Changeable Values

A PC field value of 1h requests that the ATAPI CD-ROM Drive return a mask denoting those mode parameters that are changeable. In the mask, the fields of the mode parameters that are changeable shall be set to all one bits and the fields of the mode parameters that are non-changeable (i.e. defined by the ATAPI CD-ROM Drive) *shall* be set to all zero bits.

An attempt to change a non-changeable mode parameter (via MODE SELECT) results in an error condition.

The Host Computer *shall* issue a MODE SENSE command with the PC field set to 1h and the Page Code field set to 3Fh to determine which mode pages are supported, which mode parameters within the mode pages are changeable, and the supported length of each mode page prior to issuing any MODE SELECT commands.

9.8.4.3 Default Values

A PC field value of 2h requests that the ATAPI CD-ROM Drive return the default values of the mode parameters. Parameters not supported by the ATAPI CD-ROM Drive shall be set to zero. Default values are accessible even if the device is not ready.

9.8.4.4 Saved Values

A PC field value of 3h requests that the ATAPI CD-ROM Drive return the saved values of the mode parameters. Implementation of saved page parameters is optional. Mode parameters not supported by the ATAPI CD-ROM Drive *shall* be set to zero. If saved values are not implemented, the command *shall* be terminated with CHECK CONDITION status, the sense key set to ILLEGAL REQUEST and the additional sense code set to SAVING PARAMETERS NOT SUPPORTED.

The method of saving parameters is vendor-specific. The parameters are preserved in such a manner that they are retained when the ATAPI CD-ROM Drive is powered down. All savable pages can be considered saved when a MODE SELECT command issued with the SP bit set to one has returned a "good" status.

Note: As CD-ROM devices do not have writable media and the media is removable, most will not support Saved Values. It is recommended that the Host software not make use of saved pages.

9.8.4.5 Initial Responses

After a power-up condition or hard reset condition, the ATAPI CD-ROM Drive *shall* respond in the following manner:

1. If default values are requested, report the default values.

2. If saved values are requested, report valid restored mode parameters, or restore the mode parameters and report them. If the saved values of the mode parameters are not able to be accessed from the non-volatile, vendor-specific location, terminate the command with CHECK CONDITION status and set the sense key set to NOT READY. If saved parameters are not implemented, respond as defined in "9.8.4.4 Saved Values" on page 86.

If current values are requested and the current values of the mode parameters have not been sent by the Host Computer (via a MODE SELECT command), the ATAPI CD-ROM Drive may return either the default or saved values as defined above. If current values have been sent, the current values *shall* be reported.

Table 41 - Recommended Sense Key, ASC and ASCQ for Mode Sense Command Errors

Sense Key	ASC	ASCQ	Description of Error
05	20		INVALID COMMAND OPERATION CODE
05	24		INVALID FIELD IN COMMAND PACKET
06	28		NOT READY TO READY TRANSITION
06	29		POWER ON, RESET OR BUS DEVICE RESET OCCURRED
05	1A		PARAMETER LIST LENGTH ERROR
05	39		SAVING PARAMETERS NOT SUPPORTED

Preliminary Draft
for Review Only

9.8.5 Mode Select/Sense Parameters

This section describes the pages used with MODE SELECT and MODE SENSE commands.

The Mode Parameter List contains a header, followed by zero or more variable-length pages.

Table 42 - Mode Parameter List

Bit Byte	7	6	5	4	3	2	1	0
0 - n	Mode Parameter Header							
0 - n	Page(s)							

Each mode page contains a page code, a page length, and a set of mode parameters.

Table 43 - Mode Page Codes for CD-ROM

Page code	Description	Section	Type
00h	Vendor-specific (does not require page format)		
01h	Read error recovery page	9.8.5.3 on page 95	M
02h - 0Ch	Reserved		
0Dh	CD-ROM page	9.8.5.2 on page 94	M
0Eh	CD-ROM audio control page	9.8.5.1 on page 90	M
2Ah	CD-ROM Capabilities & Mechanical Status Page	9.8.5.4 on page 99	M
0Fh - 1Fh	Reserved		
20h-29h, 2Bh-3Eh	Vendor-specific (page format required)		
3Fh	Return all pages (valid only for the MODE SENSE command)		

Table 44 - Mode Page Format

Bit Byte	7	6	5	4	3	2	1	0
0	PS/ Reserved	Reserved	Page Code					
1	Page Length (n-1)							
2	Mode Parameters							
n								

When using the MODE SENSE command, a Parameters Savable (PS) bit of one indicates that the mode page can be saved by the ATAPI CD-ROM Drive in a non-volatile, vendor-specific location. A PS bit of zero indicates that the supported parameters cannot be saved. When using the MODE SELECT command, the PS bit is reserved.

The Page Code field identifies the format and parameters defined for that mode page.

When using the MODE SENSE command, if Page Code 00h (vendor-specific page) is implemented, the ATAPI CD-ROM Drive *shall* return that page last in response to a request to return all pages (page code 3Fh). When using the

MODE SELECT command, this page *shall* be sent last.

The Page Length field specifies the length in bytes of the mode parameters that follow. If the Host Computer does not set this value to the value that is returned for the page by the MODE SENSE command, the ATAPI CD-ROM Drive *shall* terminate the command with CHECK CONDITION status. The sense key *shall* be set to ILLEGAL REQUEST with the additional sense code set to INVALID FIELD IN PARAMETER LIST. The ATAPI CD-ROM Drive is permitted to implement a mode page that is less than the full page length defined in this Specification, provided no field is truncated and the Page Length field correctly specifies the actual length implemented.

The mode parameters for each page are defined here. Mode parameters not implemented by the ATAPI CD-ROM Drive *shall* be set to zero.

Table 45 - Mode Parameter Header

Bit Byte	7	6	5	4	3	2	1	0
0	Mode Data Length							
1								
2	Medium Type							
3	Reserved							
4	Reserved							
5	Reserved							
6	Reserved							
7								

When using the MODE SENSE command, the mode data length field specifies the length in bytes of the following data that is available to be transferred. The mode data length is the total byte count of all data following the mode data length field. When using the MODE SELECT command, this field is reserved.

Table 46 - CD-ROM Medium Type Codes

Code	Medium Type Description
00h	Door closed / caddy inserted, medium type unknown
01h	120 mm CD-ROM data only, door closed or caddy inserted
02h	120 mm CD-DA audio only, door closed or caddy inserted
03h	120 mm CD-ROM data and audio combined, door closed or caddy inserted
04h	120 mm CD-ROM Hybrid disc (Photo CD), door closed or caddy inserted
05h	80 mm CD-ROM data only, door closed or caddy inserted
06h	80 mm CD-DA audio only, door closed or caddy inserted
07h	80 mm CD-ROM data and audio combined, door closed or caddy inserted
08h	80 mm CD-ROM Hybrid disc (Photo CD), door closed or caddy inserted
09h - 6Fh	Reserved
70h	Door closed, no disc present
71h	Door open or no caddy inserted
72h	Door closed or caddy inserted, medium format error
73h - 7Fh	Reserved
80h - FFh	Vendor-specific

9.8.5.1 CD-ROM Audio Control Parameters Page

The CD-ROM Audio Control Parameters Page sets the playback modes and output controls for subsequent PLAY AUDIO commands and any current audio playback operation.

Table 47 - CD-ROM Audio Control Mode Page Format

Bit Byte	7	6	5	4	3	2	1	0
0	PS (Optional)	Reserved	Page Code (0Eh)					
1	Page Length (0Eh or (0Eh * 8 * The Number of Stereo ADPCM Decoders))							
2	Reserved					Immed (Mandatory) Always 1	SOTC (Mandatory) Default 0	Reserved
3	Reserved							
4	Reserved							
5	Reserved							
6	Logical Block Per Second of Audio Playback							
7	Default 0							
8	Reserved			CDDA Output Port 0 Channel Selection				
9	Output Port 0 Volume (Mandatory) Default FFh							
10	Reserved			CDDA Output Port 1 Channel Selection				
11	Output Port 1 Volume (Mandatory) Default FFh							
12	Reserved			CDDA Output Port 2 Channel Selection				
13	Output Port 2 Volume (Optional) Default 00h							
14	Reserved			CDDA Output Port 3 Channel Selection				
15	Output Port 3 Volume (Optional) Default 00h							
16	Buffer Status	Reserved		ADPCM Device 0 Channel Selection (Default 00)				
17	Volume Right to Output Port 0 (Optional)*							
18	Reserved							
19	Volume Right to Output Port 1 (Optional)*							
20	Reserved							
21	Volume Left to Output Port 0 (Optional)*							
22	Reserved							
23	Volume Left to Output Port 1 (Optional)*							
...	Repeat Bytes 16-23 fifteen times for sixteen possible ADPCM devices)							
143	Volume Left to Output Port 1 (Optional)*							

* Note: ADPCM volume control bytes are optional, and are not required for a valid audio control mode page. However, if any one of the 8 bytes which control the audio for a given ADPCM device are supported, then all 8 bytes shall be supported.

The audio control mode page is split into three sections. Bytes 0-7 define the audio control bytes common to both the Red Book audio decoders and the ADPCM decoders. Bytes 8-15 define the audio control bytes specific to the four Red Book audio decoders. Bytes 16-143, define the audio control bytes specific to the sixteen optional stereo ADPCM decoders. Note that Byte 1, Page Length, indicates to the Host how many of the Optional Stereo ADPCM decoders are supported by the device.

The Parameters Savable (PS) bit is only used with the MODE SENSE command. The PS bit is optional. This bit is reserved with the MODE SELECT command. A PS bit of one indicates that the ATAPI CD-ROM Drive is capable of sav-

ing the page in a non-volatile vendor-specific location.

The Immediate Bit (Immed) is used for information purposes only; the audio commands will always send completion status as soon as the playback operation has been started. This bit *shall* always be set to 1.

A Stop On Track Crossing (SOTC) bit of zero indicates the ATAPI CD-ROM Drive *shall* terminate the audio playback operation when the transfer length is satisfied. Multiple tracks *shall* be played as necessary. Periods of time encoded as audio pause/silence at the beginning of tracks, (index 0) *shall* also be played. A SOTC bit of one indicates the ATAPI CD-ROM Drive *shall* terminate the audio playback operation when the beginning of a following track is encountered. The SOTC bit is mandatory.

The CDDA Output Port Channel Selection field specifies the Red Book audio channels from the disc to which a specific output port *shall* be connected. More than one output port may be connected to an audio channel. More than one audio channel may be connected to an output port.

Table 48 - CDDA Output Port Channel Selection Codes

Code	Description
0000b	Output port muted
0001b	Connect audio channel 0 to this output port
0010b	Connect audio channel 1 to this output port
0011b	Connect audio channel 1 and audio channel 2 to this output port
0100b	Connect audio channel 2 to this output port
1000b	Connect audio channel 3 to this output port

The Output Port Volume Control indicates the relative volume level for this audio output port. The value used is specified as an attenuation of the normal volume level. A value of zero indicates the minimum volume level (Mute), and a value of FFh indicates maximum volume (No attenuation) level. It is recommended that the MUTE and volume functions should be supported on a per channel basis. The attenuation used *shall* be as specified in "Table 49 - Attenuation Levels for Audio". All values not shown in the table *shall* be valid, with the attenuation selected by interpolating using the known table values.

It is recommended that the Drive support at least 16 volume levels. The actual attenuation levels for any given Binary attenuation value *shall* be given by the following equation: $20 \text{ Log (Binary Level / 256)}$

Note: Audio channel volume control regarding channel selection of MUTE vs. Volume Level setting of 0. It is recommend that drives allow the setting of the Channel Selection fields to MUTE and also allow the setting of the Volume Level field to 0. It is up to the drive to determine how to shut off the volume, either via muting circuitry or via the volume control.

Table 49 - Attenuation Levels for Audio

Binary Level	Attenuation
FFh	0db (On)
F0h	-0.56
E0h	-1.16
C0h	-2.50
80h	-6.00
40h	-12.0
20h	-18.0
10h	-24.0
0Fh	-24.6
0Eh	-25.2
0Ch	-26.6
08h	-30.0
04h	-36.0
02h	-42.1
01h	-48.0
00h	Mute (Off)

Preliminary Draft
for Review Only

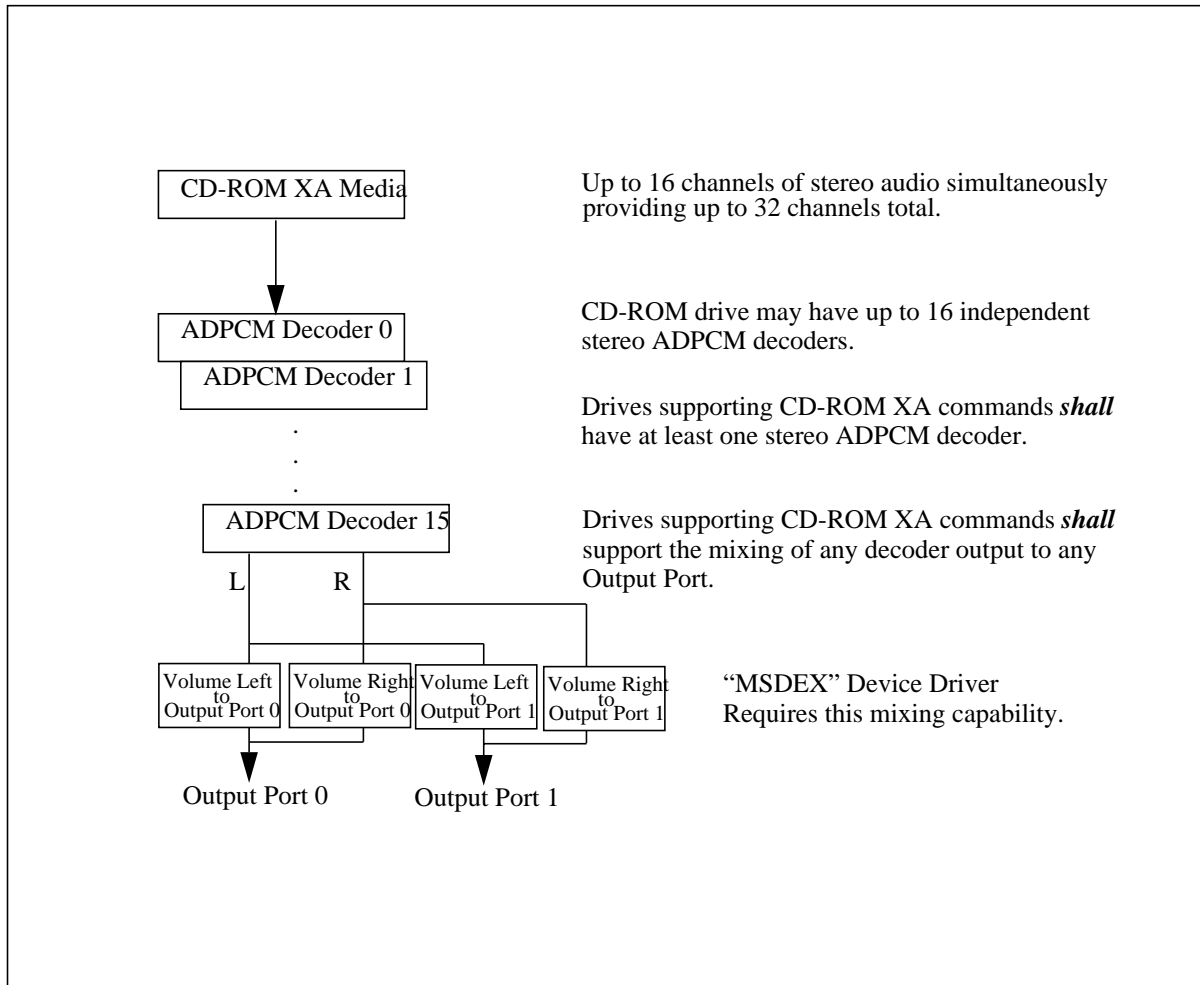

Figure 14 - ADPCM Volume MUX / Control

The ADPCM Device Channel Selection field specifies the XA ADPCM audio channels from the disc to which a specific output port *shall* be connected. More than one output port may be connected to an audio channel. More than one audio channel may be connected to an output port. Note that there are four volume controls for each of the sixteen possible stereo ADPCM devices.

9.8.5.2 CD-ROM Device Parameters Page

The CD-ROM Device parameters page specifies parameters that affect all CD-ROM data types.

Table 50 - CD-ROM Parameters Page Format

Bit Byte	7	6	5	4	3	2	1	0
0	PS (Optional) Default 0	Reserved	Page Code (0Dh)					
1	Page Length (06h)							
2	Reserved							
3	Reserved				Inactivity Time Multiplier			
4	Number of MSF - S Units per MSF - M Unit Default 60 (3Ch)							
5								
6								
7								

The Parameters Savable (PS) bit is only used with the MODE SENSE command. This bit is reserved with the MODE SELECT command. A PS bit of one indicates that the ATAPI CD-ROM Drive is capable of saving the page in a non-volatile vendor-specific location. The PS bit is optional.

The Inactivity Timer Multiplier specifies the length of time that the drive *shall* remain in the hold track state after completion of a seek or read operation.

NOTE Higher values in this parameter may have an adverse effect on the drive MTBF, in some implementations.

Table 51 - Inactivity Time Multiplier Values

Inactivity Timer Multiplier	Minimum Time in Hold Track State	Inactivity Timer Multiplier	Minimum Time in Hold Track State
0h	Vendor-specific	8h	16s
1h	125 ms	9h	32s
2h	250 ms	Ah	1 min
3h	500 ms	Bh	2 min
4h	1 s	Ch	4 min
5h	2 s	Dh	8 min
6h	4 s	Eh	16 min
7h	8 s	Fh	32 min

The number of S units per M unit field gives the ratio of these MSF address values. For media conforming to the CD-ROM and CD-DA Specification, this value is 60.

The number of F units per S unit field gives the ratio of these MSF address values. For media conforming to the CD-ROM and CD-DA Specification, this value is 75.

9.8.5.3 Read Error Recovery Parameters Page

The Read Error Recovery Parameters Page specifies the error recovery parameters the ATAPI CD-ROM Drive *shall* use during any command that performs a data read operation from the media (e.g. READ, READ TOC, etc.).

Table 52 - Read Error Recovery Parameters Page Format

Bit Byte	7	6	5	4	3	2	1	0
0	PS (Optional) Default 0	Reserved	Page Code (01h)					
1	Page Length (06h)							
2	Error Recovery Parameter, Default 0							
	Reserved		TB	RC	Reserved	PER	DTE	DCR
3	Read Retry Count							
4	Reserved							
5	Reserved							
6	Reserved							
7	Reserved							

The Parameters Savable (PS) bit is only used with the MODE SENSE command. This bit is reserved with the MODE SELECT command. A PS bit of one indicates that the ATAPI CD-ROM Drive is capable of saving the page in a non-volatile vendor-specific location. The PS bit is optional.

NOTE The implementation of error recovery procedures for CD-ROM devices is markedly different from those used for magnetic medium disk drives. At least one level of error correction (i.e. CIRC) is required to transfer the data stream. Therefore, the performance of the drive may differ substantially from what would be expected by sending the same error recovery parameters to a magnetic medium device.

A Transfer Block (TB) bit of one indicates that a data block that is not recovered within the recovery limits specified, *shall* be transferred to the Host Computer before CHECK CONDITION status is returned. A TB bit of zero indicates that such a data block *shall not* be transferred to the Host Computer. The TB bit does not affect the action taken for recovered data.

A Read Continuous (RC) bit of one indicates that the CD-ROM drive *shall* transfer the entire requested length of data without adding delays to perform error recovery procedures. This implies that the CD-ROM drive may send data that is erroneous or fabricated in order to maintain a continuous flow of data. A RC bit of zero indicates that error recovery operations that cause delays are acceptable during the data transfer.

A Post Error (PE) bit of one indicates that the CD-ROM drive *shall* report recovered errors. A PER bit of zero indicates that the CD-ROM drive *shall not* report recovered errors. Error recovery procedures *shall* be performed within the limits established by the error recovery parameters.

A Disable Transfer on Error (DTE) bit of one indicates that the CD-ROM drive *shall* terminate the data transfer to the Host upon detection of a recovered error. A DTE bit of zero indicates that the CD-ROM drive *shall not* terminate the data transfer upon detection of a recovered error.

A Disable Correction (DCR) bit of one indicates that error correction codes *shall not* be used for data error recovery. A DCR bit of zero allows the use of error correction codes for data error recovery.

The correlation of the error recovery parameter and the bit settings defined for CD-ROM devices is given in "Table 53 - Error Recovery Bit Settings" on page 96. The interpretation of these bit settings for CD-ROM devices is given in "Table 54 - CD-ROM Error Recovery Descriptions" on page 96. If the error recovery parameter is set to any other value, the

command *shall* be terminated with CHECK CONDITION status. The sense key *shall* be set to ILLEGAL REQUEST and the additional sense code set to INVALID FIELD IN PARAMETER LIST.

Table 53 - Error Recovery Bit Settings

Error Recovery Parameter	Bit Settings 7 6 5 4 3 2 1 0	Error Recovery Parameter	Bit Settings 7 6 5 4 3 2 1 0
00h	R R 0 0 R 0 0 0	20h	R R 1 0 R 0 0 0
01h	R R 0 0 R 0 0 1	21h	R R 1 0 R 0 0 1
04h	R R 0 0 R 1 0 0	24h	R R 1 0 R 1 0 0
05h	R R 0 0 R 1 0 1	25h	R R 1 0 R 1 0 1
06h	R R 0 0 R 1 1 0	26h	R R 1 0 R 1 1 0
07h	R R 0 0 R 1 1 1	27h	R R 1 0 R 1 1 1
10h	R R 0 1 R 0 0 0	30h	R R 1 1 R 0 0 0
11h	R R 0 1 R 0 0 1	31h	R R 1 1 R 0 0 1
14h	R R 0 1 R 1 0 0	34h	R R 1 1 R 1 0 0
15h	R R 0 1 R 1 0 1	35h	R R 1 1 R 1 0 1

NOTE Reserved bits *shall* be set to zero.

Table 54 - CD-ROM Error Recovery Descriptions

Code	Error Recovery Description
00h	The maximum error recovery procedures available are used. If an error occurs which is uncorrectable with the error correction codes (ECC) on the media, data transfer is terminated with CHECK CONDITION status. The block with the error is not transferred. The sense key is set to MEDIUM ERROR. The information bytes give the address of the block where the unrecovered error was detected. Recovered errors are not reported.
01h	Only retries of the read operation and CIRC are used (layered error correction is not used). Only CIRC unrecovered data errors are reported. If a CIRC unrecovered data error occurs, data transfer is terminated with CHECK CONDITION status. The block with the error is not transferred. The sense key is set to MEDIUM ERROR. The information bytes give the address of the block where the unrecovered error was detected. Recovered errors are not reported.
04h	The maximum error recovery procedures available are used. Recovered data errors are reported. If a recovered data error occurs, data transfer is not terminated. However, when the data transfer has completed CHECK CONDITION status is reported. The sense key is set to RECOVERED ERROR. The information bytes give the address of the last block where a recovered data error was detected. If a data error occurs that is uncorrectable with the ECC information available on the media, data transfer is terminated and CHECK CONDITION status is reported. The block with the error is not transferred. The sense key is set to MEDIUM ERROR. The information bytes give the address of the block where the uncorrectable error was detected.
05h	Only retries of the read operation and CIRC are used (layered error correction is not used). Recovered data errors are reported. If a recovered data error occurs, data transfer is not terminated. However, when the data transfer has completed CHECK CONDITION status is reported. The sense key is set to RECOVERED ERROR. The information bytes give the address of the last block where a CIRC recovered data error was detected. If an unrecovered data error occurs, data transfer is terminated and CHECK CONDITION status is reported. The block with the error is not transferred. The sense key is set to MEDIUM ERROR. The information bytes give the address of the block where the unrecovered error was detected.

Table 54 - CD-ROM Error Recovery Descriptions

Code	Error Recovery Description
06h	The maximum error recovery procedures are used. Recovered data errors are reported. If a recovered data error occurs data transfer is terminated and CHECK CONDITION status is reported. The block with the recovered error is not transferred. The sense key is set to RECOVERED ERROR. The information bytes give the address of the block where the recovered data error was detected. If a data error occurs that is uncorrectable with the ECC information on the medium, data transfer is terminated with CHECK CONDITION status. The block with the error is not transferred. The sense key is set to MEDIUM ERROR. The information bytes give the address of the block where the uncorrectable error was detected.
07h	Only retries of the read operation are used (layered error correction is not used) and CIRC recovered data errors are reported. If a CIRC recovered data error occurs, data transfer is terminated with CHECK CONDITION status. The block with the recovered error is not transferred. The sense key is set to RECOVERED ERROR. The information bytes give the address of the block where the recovered data error was detected. If a CIRC unrecovered data error occurs, data transfer is terminated with CHECK CONDITION status. The block with the error is not transferred. The sense key is set to MEDIUM ERROR. The information bytes give the address of the block where the unrecovered error was detected.
10h	If data transfer can be maintained, the maximum error recovery procedures available are used. (RC = 1.) If an error occurs which is uncorrectable with the error correction codes (ECC) on the media, or is uncorrectable in time to maintain data transfer, the data transfer is not terminated. However, when the data transfer has completed, CHECK CONDITION status is reported. The sense key is set to MEDIUM ERROR. The information bytes give the address of the block where the first unrecovered error was detected. Recovered errors are not reported.
11h	If data transfer can be maintained, retries of the read operation and CIRC are used (layered error correction is not used). (RC = 1.) Only CIRC unrecovered data errors are reported. If a CIRC unrecovered data error occurs, data transfer is not terminated. However, when the data transfer has completed, CHECK CONDITION status is reported. The sense key is set to MEDIUM ERROR. The information bytes give the address of the block where the first unrecovered error was detected. Recovered errors are not reported.
14h	If data transfer can be maintained, the maximum error recovery procedures available are used. (RC = 1.) Recovered data errors are reported. If a recovered data error occurs, data transfer is not terminated. However, when the data transfer has completed, CHECK CONDITION status is reported. The sense key is set to RECOVERED ERROR. The information bytes give the address of the block where a recovered data error was detected. If an data error occurs that is uncorrectable with the ECC information available on the media, or is uncorrectable in time to maintain data transfer, the data transfer is not terminated. However, when the data transfer has completed CHECK CONDITION, status is reported. The sense key is set to MEDIUM ERROR. The information bytes give the address of the block where the first uncorrectable error was detected. Reporting unrecovered errors takes precedence over reporting recovered errors.
15h	If data transfer can be maintained, retries of the read operation and CIRC are used (layered error correction is not used). (RC = 1.) Recovered data errors are reported. If a recovered data error occurs, data transfer is not terminated. However, when the data transfer has completed CHECK CONDITION status is reported. The sense key is set to RECOVERED ERROR. The information bytes give the address of the block where a CIRC recovered data error was detected. If an unrecovered data error occurs, data transfer is not terminated. However, when the data transfer has completed CHECK CONDITION status is reported. The sense key is set to MEDIUM ERROR. The information bytes give the address of the block where the first unrecovered error was detected. Reporting unrecovered errors takes precedence over reporting recovered errors.
20h	The maximum error recovery procedures available are used. If an error occurs which is uncorrectable with the error correction codes (ECC) on the media, data transfer is terminated with CHECK CONDITION status. The block with the error is transferred. The sense key is set to MEDIUM ERROR. The information bytes give the address of the block where the unrecovered error was detected. Recovered errors are not reported.
21h	Only retries of the read operation and CIRC are used (layered error correction is not used). Only CIRC unrecovered data errors are reported. If a CIRC unrecovered data error occurs data transfer is terminated with CHECK CONDITION status. The block with the error is transferred. The sense key is set to MEDIUM ERROR. The information bytes give the address of the block where the unrecovered error was detected. Recovered errors are not reported.
24h	The maximum error recovery procedures available are used. Recovered data errors are reported. If a recovered data error occurs data transfer is not terminated. However, when the data transfer has completed, CHECK CONDITION status is reported. The sense key is set to RECOVERED ERROR. The information bytes give the address of the last block where a recovered data error was detected. If a data error occurs that is uncorrectable with the ECC information available on the media data transfer is terminated and CHECK CONDITION status is reported. The block with the error is transferred. The sense key is set to MEDIUM ERROR. The information bytes give the address of the block where the uncorrectable error was detected.

Table 54 - CD-ROM Error Recovery Descriptions

Code	Error Recovery Description
25h	Only retries of the read operation and CIRC are used (layered error correction is not used). Recovered data errors are reported. If a recovered data error occurs, data transfer is not terminated. However, when the data transfer has completed, CHECK CONDITION status is reported. The sense key is set to RECOVERED ERROR. The information bytes give the address of the last block where a CIRC recovered data error was detected. If an unrecovered data error occurs, data transfer is terminated and CHECK CONDITION status is reported. The block with the error is transferred. The sense key is set to MEDIUM ERROR. The information bytes give the address of the block where the unrecovered error was detected.
26h	The maximum error recovery procedures are used. Recovered data errors are reported. If a recovered data error occurs, data transfer is terminated and CHECK CONDITION status is reported. The block with the recovered error is transferred. The sense key is set to RECOVERED ERROR. The information bytes give the address of the block where the recovered data error was detected. If a data error occurs that is uncorrectable with the ECC information on the media, data transfer is terminated with CHECK CONDITION status. The block with the error is transferred. The sense key is set to MEDIUM ERROR. The information bytes give the address of the block where the uncorrectable error was detected.
27h	Only retries of the read operation are used (layered error correction is not used). CIRC recovered data errors are reported. If a CIRC recovered data error occurs, data transfer is terminated with CHECK CONDITION status. The block with the recovered error is transferred. The sense key is set to RECOVERED ERROR. The information bytes give the address of the block where the recovered data error was detected. If a CIRC unrecovered data error occurs, data transfer is terminated with CHECK CONDITION status. The block with the error is transferred. The sense key is set to MEDIUM ERROR. The information bytes give the address of the block where the unrecovered error was detected.
30h	Same as code 10H.
31h	Same as code 11H.
34h	Same as code 14H.
35h	Same as code 15H.

The Read Retry Count field specifies the number of times that the controller *shall* attempt its read recovery algorithm.

A CIRC Recovered Data Error is defined as a block for which the CIRC based error correction algorithm was unsuccessful for a read attempt, but on a subsequent read operation no error was reported. The number of subsequent read operations is limited to the read retry count. Layered error correction was not used.

A CIRC Unrecovered Data Error is defined as a block for which the CIRC based error correction algorithm was unsuccessful on all read attempts up to the read retry count. Layered error correction was not used.

An L-EC Recovered Data Error is defined as a block for which the CIRC based error correction algorithm was unsuccessful, but the layered error correction was able to correct the block within the read retry count.

An L-EC Uncorrectable Data Error is defined as a block which could not be corrected by layered error correction within the read retry count.

9.8.5.4 CD-ROM Capabilities and Mechanical Status Page

The Capabilities Page is read only and may not be set with Mode Select.

Table 55 - CD-ROM Capabilities and Mechanical Status Page Format

Bit Byte	7	6	5	4	3	2	1	0
0	PS (Optional) Default 0	Reserved	Page Code (2Ah)					
1	Page Length (0Eh)							
2	Reserved							
3	Reserved							
4 - 7 32 bit field of Capability bits	Reserved	Multi Session	Mode 2 Form 2	Mode 2 Form 1	Reserved	Reserved	XA Cmds Supported	AudioPlay
	Reserved	UPC	ISRC	C2Pointers are supported	R-W De-inter-leaved & corrected	R-W Supported	CD-DA Stream is Accurate	CD DA Commands Supported
	Loading Mechanism Type			Reserved	Eject	Prevent Jumper	Lock State	Lock
	Reserved						Separate Channel Mute Supported	Separate volume levels per channel
8	MSB	Maximum Speed Supported (in Kbps)						LSB
9								
10	MSB	Number of Volume Levels Supported						LSB
11								
12	MSB	Buffer Size supported by Drive (in KBytes)						LSB
13								
14	MSB	Current Speed Selected (in Kbps)						LSB
15								
16	Reserved for number of ADPCM Decoders							
17 - 20	Reserved							

The individual capabilities of the drive are specified by bytes 4 through 7. Each of the bits indicate if that specific capability is supported. A value of zero indicates that the capability is NOT supported; a value of one indicates the capability IS supported.

- Bit 0 Audio Play The drive is capable of Audio Play operation. This also indicates that the drive is capable of overlapping Play and other commands such as reading of the Sub-channel information.
- Bit 1 XA Commands Supported This bit has been reserved for future support of CD-ROM XA commands. The bit indicates that the drive supports CD-ROM XA commands. Drives which set this bit *shall* support all CD-ROM XA commands.
- Bit 4 Mode 2 Form 1 The drive is capable of reading sectors in Mode 2 Form 1 (XA) format.
- Bit 5 Mode 2 Form 2 The drive is capable of reading sectors in Mode 2 Form 2 format.

Bit 6	Multi Session	The drive is capable of reading multiple session or Photo-CD discs.
Bit 8	READ CD-DA	Red Book audio can be read using the READ-CD command.
Bit 9	CD-DA Stream is Accurate	This bit indicates that the drive supports an advanced feature that allows it to return to an audio location without losing place to continue the READ CD-DA command. 0 The drive is incapable of accurately restarting the CD-DA read operation, and a BUFFER OVERFLOW error <i>shall</i> be reported whenever a loss of streaming occurs. This error will be fatal and the command will have to be repeated from the beginning. 1 The drive can continue from a loss of streaming condition and no error will be generated.
Bit 10	R-W Supported	The commands that return Sub-channel data can return the combined R-W information.
Bit 11	R-W De-interleaved & Corrected	This indicates that the R-W sub-channel data will be returned de-interleaved and error corrected.
Bit 12	C2 Pointers are Supported	This indicates that the drive supports the C2 Error Pointers. This also indicates that the drive is capable of returning the C2 Error Pointers and C2 Block Error flags in the READ CD command.
Bit 13	UPC	The drive can return the Media Catalog Number (UPC)
Bit 14	ISRC	The drive can return the International Standard Recording Code Information.
Bit 16	Lock	The PREVENT/ALLOW command is capable of actually locking the media into the drive.
Bit 17	Lock State	This indicates the current state of the drive. 0 The drive is currently in the allow (Unlocked) state. Media may be inserted or ejected. 1 The drive is currently in the prevent (Locked) state. Media loaded in the drive may not be removed via a soft or hard eject. If the drive is empty, media may not be inserted if the Prevent Jumper is not present. If the jumper is present, then media may be inserted.
Bit 18	Prevent Jumper	This indicates the state of the (Optional) Prevent/Allow Jumper. 0 Jumper is present. Drive will power up to the allow state. Locking the drive with the Prevent/Allow Command <i>shall</i> NOT prevent the insertion of media. 1 Jumper is not present. Drive will power up to the Prevent State (Locked). The drive will not accept new media or allow the ejection of media already loaded until an allow command is issued.
Bit 19	Eject Command	The drive can eject the disc via the normal START/STOP command with the LoEj bit set.

- Bit 23-21 Loading Mechanism Type This field specifies the type of disc loading the drive supports.
- | | | | |
|----|----|----|-------------------------------|
| 23 | 22 | 21 | |
| 0 | 0 | 0 | Caddy type loading mechanism |
| 0 | 0 | 1 | Tray type loading mechanism |
| 0 | 1 | 0 | Pop-up type loading mechanism |
| 0 | 1 | 1 | Reserved |
| 1 | x | x | Reserved |
- Bit 24 Separate Volume Levels The audio level for each channel can be controlled independently.
- Bit 24 Separate Channel Mute The mute capability for each channel can be controlled independently.

The Maximum Speed Supported field indicates the actual maximum data rate that the drive supports. This value is returned as the number of kilobytes per/second (Speed/1000) that the data is read from the drive.

Table 56 - Example Data Rates

Speed	Data Rate
X1	176 KBytes/second
X2	353 KBytes/second
X2.2	387 KBytes/second
X3	528 KBytes/second
X4	706 KBytes/second

Note that these are the raw data rates and do not reflect any overhead resulting from headers, error correction data, etc. It is also important to understand that the reported data rate is a theoretical maximum and the actual data rates to the host will be lower.

The Number of Volume Levels Supported field returns the number of discrete levels. If the drive only supports turning audio on and off, the Number of Volume Levels field **shall** be set to 2.

The Buffer Size Supported field returns the number of bytes of buffer dedicated to the data stream returned to the Host Computer. This value is returned in Kbytes (Size/1024). If the drive does not have a buffer cache, the value returned **shall** be zero.

The Current Speed Selected field indicates the actual data rate that the drive is currently using. This value is returned as the number of kilobytes per/second (Speed/1000) that the data is read from the drive.

Preliminary Draft
for Review Only

Intentionally Left Blank

9.8.6 PAUSE/RESUME Command

The PAUSE/RESUME command requests that the device stop or start an audio play operation. This command is used with PLAY AUDIO commands that are currently executing.

Table 57 - PAUSE/RESUME Command

Bit Byte	7	6	5	4	3	2	1	0
0	Operation Code (4Bh)							
1	Reserved							
2	Reserved							
3	Reserved							
4	Reserved							
5	Reserved							
6	Reserved							
7	Reserved							
8	Reserved							Resume
9	Reserved							
10	Reserved							
11	Reserved							

A Resume bit of zero causes the drive to enter the hold track state with the audio output muted after the current block is played. A Resume bit of one causes the drive to release the pause and begin play at the block following the last block played.

If an audio play operation cannot be resumed and the resume bit is one, the command is terminated with CHECK CONDITION status. If the resume bit is zero and an audio play operation cannot be paused, (no audio play operation has been requested, or the requested audio play operation has been completed), the command is terminated with CHECK CONDITION status. See "Figure 17 - Stop Play/Play Audio/Audio Scan/Pause/Resume Sequencing" on page 168 for additional information.

It **shall not** be considered an error to request a PAUSE when a pause is already in effect or to request a RESUME when a play operation is in progress.

Table 58 - Recommended Sense Key, ASC and ASCQ for Pause/Resume Command Errors

Sense Key	ASC	ASCQ	Description of Error
05	20		INVALID COMMAND OPERATION CODE
05	24		INVALID FIELD IN COMMAND PACKET
06	28		NOT READY TO READY TRANSITION
06	29		POWER ON, RESET OR BUS DEVICE RESET OCCURRED
02	04	00	LOGICAL UNIT NOT READY - CAUSE NOT REPORTABLE
02	04	01	LOGICAL UNIT NOT READY - IN PROGRESS OF BECOMING READY
02	04	02	LOGICAL UNIT NOT READY - INITIALIZING COMMAND REQUIRED
02	04	03	LOGICAL UNIT NOT READY - MANUAL INTERVENTION REQUIRED
02	3A		MEDIUM NOT PRESENT
0B	B9		AUDIO PLAY OPERATION ABORTED

Preliminary Draft
for Review Only

Intentionally Left Blank

9.8.7 PLAY AUDIO (10) Command

The PLAY AUDIO command requests that the ATAPI CD-ROM Drive begin an audio playback operation. The command function and the output of audio signals *shall* be as specified by the settings of the mode parameters, including the SOTC bit.

Table 59 - PLAY AUDIO Command

Bit Byte	7	6	5	4	3	2	1	0
0	Operation Code (45h)							
1	Reserved							
2	Starting Logical Block Address							
3								
4								
5								
6	Reserved							
7	Transfer Length							
8								
9	Reserved							
10	Reserved							
11	Reserved							

This command responds with immediate status, allowing overlapped commands. This command *shall* set the DSC bit upon command completion. See also "9.4 Immediate Command Processing Considerations" on page 68.

If any commands related to audio operations are implemented then the PLAY AUDIO (10) command *shall* be implemented to allow a method for the Host Computer to determine if audio operations are supported. An ATAPI CD-ROM Drive responding to a PLAY AUDIO (10) command that has a transfer length of zero with CHECK CONDITION status and setting the sense key to ILLEGAL REQUEST does not support audio play operations.

The Starting Logical Block Address field specifies the logical block at which the audio playback operation *shall* begin. PLAY AUDIO commands with a starting logical block address of FFFF FFFFh *shall* implement audio play from the current location of the optics.

The Transfer Length Field specifies the number of contiguous logical blocks that *shall* be played. A Transfer Length Field of zero indicates that no audio operation *shall* occur. This condition *shall not* be considered an error.

If the starting address is not found, if the address is not within an audio track, or if a not ready condition exists, the command *shall* be terminated with CHECK CONDITION status.

If the CD-ROM information type (data vs. audio) changes within the transfer length, the command *shall* be terminated with a CHECK CONDITION and the sense key *shall* be set to ILLEGAL REQUEST and the additional sense code set to END OF USER AREA ENCOUNTERED ON THIS TRACK.

If the logical block address requested is not within an audio track, the command *shall* be terminated with CHECK CONDITION status. The sense key *shall* be set to ILLEGAL REQUEST and the additional sense code set to ILLEGAL MODE FOR THIS TRACK.

Table 60 - Recommended Sense Key, ASC and ASCQ for Play Audio Command Errors

Sense Key	ASC	ASCQ	Description of Error
05	20		INVALID COMMAND OPERATION CODE
05	24		INVALID FIELD IN COMMAND PACKET
06	28		NOT READY TO READY TRANSITION
06	29		POWER ON, RESET OR BUS DEVICE RESET OCCURRED
02	04	00	LOGICAL UNIT NOT READY - CAUSE NOT REPORTABLE
02	04	01	LOGICAL UNIT NOT READY - IN PROGRESS OF BECOMING READY
02	04	02	LOGICAL UNIT NOT READY - INITIALIZING COMMAND REQUIRED
02	04	03	LOGICAL UNIT NOT READY - MANUAL INTERVENTION REQUIRED
02	3A		MEDIUM NOT PRESENT
02	06	00	NO REFERENCE POSITION FOUND (media may be upside down)
02	30	00	INCOMPATIBLE MEDIUM INSTALLED
02	30	01	CANNOT READ MEDIUM - UNKNOWN FORMAT
02	30	02	CANNOT READ MEDIUM - INCOMPATIBLE FORMAT
03	02		NO SEEK COMPLETE
05	21		LOGICAL BLOCK ADDRESS OUT OF RANGE
05	54		ILLEGAL MODE FOR THIS TRACK
05	63		END OF USER AREA ENCOUNTERED ON THIS TRACK

9.8.7.1 Play Audio with Overlapped Packet Commands

The PLAY AUDIO commands will continue to play while other commands are processed by the drive. Some commands can be accepted without disrupting the audio operations, while others will cause the Play operation to stop. The following section describes the operation of other commands while playing audio.

A PLAY AUDIO command will be terminated when any of the commands in "Table 61 - Commands That Will Stop a Play Operation" are received.

Table 61 - Commands That Will Stop a Play Operation

Opcode(s)	Command Description
4Bh	PAUSE/RESUME
45h & A5h	PLAY AUDIO (10) & PLAY AUDIO (12)
47h	PLAY AUDIO MSF
48h	PLAY AUDIO TRACK/INDEX
49h & A9h	PLAY AUDIO TRACK RELATIVE (10 & 12)
28h & A8h	READ (10) & READ (12)
D4h	READ CD
44h	READ HEADER
D5h	READ CD MSF
01h	REZERO UNIT
2Bh	SEEK
DAh	SET CD-ROM SPEED
1Bh	START/STOP UNIT
08h	RESET COMMAND

The CD-ROM drive should accept and perform the commands specified in "Table 61 - Commands That Will Stop a Play Operation" without terminating an AUDIO PLAY command already in progress. See "Figure 17 - Stop Play/Play Audio/Audio Scan/Pause/Resume Sequencing" on page 168 for additional information.

Table 62 - Commands That Will Not Stop a Play Operation

Opcode	Command Description	Action Taken
D8h	AUDIO SCAN	SCAN command will be executed and the PLAY command will resume at completion of the scan
12h	INQUIRY	The Inquiry data will be returned
55h	MODE SELECT	The Mode Select will be accepted and executed as long as no Media or Mode information is changed. If parameters that affect the play are changed, the Mode Select will terminate with a CHECK CONDITION without being executed.
5Ah	MODE SENSE	Will execute normally
1Eh	PREVENT/ALLOW MEDIA REMOVAL	Will execute normally
25h	READ CD-ROM CAPACITY	Will execute normally
42h	READ SUB-CHANNEL	Only the current position information (Format Code 01h) will be supported while the play is in progress. If any other type of information is requested the READ SUB-CHANNEL will not be executed and a CHECK CONDITION will be generated.
43h	READ TOC	Only drives that cache the TOC will be able to respond to this command while the play is in progress. If the drive does not support caching the TOC, the command will not be executed and a CHECK CONDITION will be generated.
03h	REQUEST SENSE	Will execute normally
00h	TEST UNIT READY	Will execute normally

9.8.8 PLAY AUDIO (12) Command

The PLAY AUDIO(12) command requests that the ATAPI CD-ROM Drive begin an audio playback operation. The command function and the output of audio signals *shall* be as specified by the settings of the mode parameters including the SOTC bit. See the PLAY AUDIO (10) command for a description of the fields in this command as well as for information on overlapped command operation.

Table 63 - PLAY AUDIO (12) Command

Bit Byte	7	6	5	4	3	2	1	0
0	Operation code (A5h)							
1	Reserved							
2	Starting Logical Block Address							
3								
4								
5								
6								
6	Transfer Length							
7								
8								
9								
10	Reserved							
11	Reserved							

This command responds with immediate status, allowing overlapped commands. This command *shall* set the DSC bit upon command completion. See also "9.4 Immediate Command Processing Considerations" on page 68.

Table 64 - Recommended Sense Key, ASC and ASCQ for Play Audio (12) Command Errors

Sense Key	ASC	ASCQ	Description of Error
05	20		INVALID COMMAND OPERATION CODE
05	24		INVALID FIELD IN COMMAND PACKET
06	28		NOT READY TO READY TRANSITION
06	29		POWER ON, RESET OR BUS DEVICE RESET OCCURRED
02	04	00	LOGICAL UNIT NOT READY - CAUSE NOT REPORTABLE
02	04	01	LOGICAL UNIT NOT READY - IN PROGRESS OF BECOMING READY
02	04	02	LOGICAL UNIT NOT READY - INITIALIZING COMMAND REQUIRED
02	04	03	LOGICAL UNIT NOT READY - MANUAL INTERVENTION REQUIRED
02	06	00	NO REFERENCE POSITION FOUND (media may be upside down)
02	30	00	INCOMPATIBLE MEDIUM INSTALLED
02	30	01	CANNOT READ MEDIUM - UNKNOWN FORMAT
02	30	02	CANNOT READ MEDIUM - INCOMPATIBLE FORMAT
02	3A		MEDIUM NOT PRESENT
03	02		NO SEEK COMPLETE
05	21		LOGICAL BLOCK ADDRESS OUT OF RANGE
05	54		ILLEGAL MODE FOR THIS TRACK

9.8.9 PLAY AUDIO MSF Command

The PLAY AUDIO MSF command requests that the ATAPI CD-ROM Drive begin an audio playback operation. The command function and the output of audio signals *shall* be as specified by the settings of the mode parameters including the SOTC bit.

Table 65 - PLAY AUDIO MSF Command

Bit Byte	7	6	5	4	3	2	1	0
0	Operation Code (47h)							
1	Reserved							
2	Reserved							
3	Starting M Field							
4	Starting S Field							
5	Starting F Field							
6	Ending M Field							
7	Ending S Field							
8	Ending F Field							
9	Reserved							
10	Reserved							
11	Reserved							

This command responds with immediate status, allowing overlapped commands. This command *shall* set the DSC bit upon command completion. See also "9.4 Immediate Command Processing Considerations" on page 68.

The Starting M field, the Starting S field, and the Starting F field specify the absolute MSF address at which the audio play operation *shall* begin. The Ending M field, the Ending S field, and the Ending F field specify the absolute MSF address where the audio play operation *shall* end. All contiguous audio sectors between the starting and the ending MSF address *shall* be played.

If the Starting Minutes, Seconds and Frame Fields are set to FFh, the Starting address is taken from the Current Optical Head location. This allows the Audio Ending address to be changed without interrupting the current playback operation.

A Starting MSF address equal to an ending MSF address causes no audio play operation to occur. This *shall not* be considered an error. If the Starting MSF address is greater than the Ending MSF address, the command *shall* be terminated with CHECK CONDITION status. The sense key *shall* be set to ILLEGAL REQUEST.

If the starting address is not found, if the address is not within an audio track, or if a not ready condition exists, the command *shall* be terminated with CHECK CONDITION status.

See "9.8.7.1 Play Audio with Overlapped Packet Commands" on page 106 for information on overlapped commands during an Audio Playback.

Table 66 - Recommended Sense Key, ASC and ASCQ for Play Audio MSF Command Errors

Sense Key	ASC	ASCQ	Description of Error
05	20		INVALID COMMAND OPERATION CODE
05	24		INVALID FIELD IN COMMAND PACKET
06	28		NOT READY TO READY TRANSITION
06	29		POWER ON, RESET OR BUS DEVICE RESET OCCURRED
02	04	00	LOGICAL UNIT NOT READY - CAUSE NOT REPORTABLE
02	04	01	LOGICAL UNIT NOT READY - IN PROGRESS OF BECOMING READY
02	04	02	LOGICAL UNIT NOT READY - INITIALIZING COMMAND REQUIRED
02	04	03	LOGICAL UNIT NOT READY - MANUAL INTERVENTION REQUIRED
02	06	00	NO REFERENCE POSITION FOUND (media may be upside down)
02	30	00	INCOMPATIBLE MEDIUM INSTALLED
02	30	01	CANNOT READ MEDIUM - UNKNOWN FORMAT
02	30	02	CANNOT READ MEDIUM- INCOMPATIBLE FORMAT
02	3A		MEDIUM NOT PRESENT
03	02		NO SEEK COMPLETE
05	21		LOGICAL BLOCK ADDRESS OUT OF RANGE
05	54		ILLEGAL MODE FOR THIS TRACK
05	63		END OF USER AREA ENCOUNTERED ON THIS TRACK

Preliminary Draft
for Review

9.8.10 PLAY AUDIO TRACK RELATIVE (10) Command

The PLAY AUDIO TRACK RELATIVE (10) command requests that the device begin an audio playback operation. The starting address is specified as a track relative logical block address within the specified starting track. The command function and the output of audio signals *shall* be as specified by the settings of the mode parameters including the SOTC bit.

Table 67 - PLAY AUDIO TRACK RELATIVE (10) Command

Bit Byte	7	6	5	4	3	2	1	0
0	Operation Code (49h)							
1	Reserved							
2	Track Relative Logical Block Address							
3								
4								
5								
6								
7	Transfer Length							
8	Reserved							
9								
10								
11	Reserved							

This command responds with immediate status, allowing overlapped commands. This command *shall* set the DSC bit upon command completion. See also "9.4 Immediate Command Processing Considerations" on page 68.

The Starting Track field specifies the track number of the Starting Audio Track.

The Track Relative Logical Block Address (TRLBA) field specifies the two's complement Starting Logical Block Address relative to the beginning of the first sector on the track with an index value of one. Negative values indicate a starting location within the audio pause area at the beginning of the requested track.

The Transfer Length field specifies the number of contiguous logical blocks that *shall* be output as audio data. A Transfer Length field of zero indicates that no audio playback operation *shall* occur. This condition *shall not* be considered an error. Any other value indicates the number of logical blocks that *shall* be output.

If the Logical Block Length is not equal to the sector size the ATAPI CD-ROM Drive may adjust the Starting Logical Block Address and the Transfer Length. In such a case, it is recommended that the ATAPI CD-ROM Drive start the audio play operation with the beginning of a sector whenever the starting logical address falls within that sector (MSF unit). If the requested Transfer Length causes the end of an audio play operation to fall within a sector, the ATAPI CD-ROM Drive may continue the play operation through the end of that sector.

If the Starting Address is not found, or if the address is not within an audio track, or if a NOT READY condition exists, the command is terminated with CHECK CONDITION status.

See "9.8.7.1 Play Audio with Overlapped Packet Commands" on page 106 for information on overlapped commands during an Audio Playback.

Table 68 - Recommended Sense Key, ASC and ASCQ for Play Track Relative (10) Command Errors

Sense Key	ASC	ASCQ	Description of Error
05	20		INVALID COMMAND OPERATION CODE
05	24		INVALID FIELD IN COMMAND PACKET
06	28		NOT READY TO READY TRANSITION
06	29		POWER ON, RESET OR BUS DEVICE RESET OCCURRED
02	04	00	LOGICAL UNIT NOT READY - CAUSE NOT REPORTABLE
02	04	01	LOGICAL UNIT NOT READY - IN PROGRESS OF BECOMING READY
02	04	02	LOGICAL UNIT NOT READY - INITIALIZING COMMAND REQUIRED
02	04	03	LOGICAL UNIT NOT READY - MANUAL INTERVENTION REQUIRED
02	06	00	NO REFERENCE POSITION FOUND (media may be upside down)
02	30	00	INCOMPATIBLE MEDIUM INSTALLED
02	30	01	CANNOT READ MEDIUM - UNKNOWN FORMAT
02	30	02	CANNOT READ MEDIUM - INCOMPATIBLE FORMAT
02	3A		MEDIUM NOT PRESENT
03	02		NO SEEK COMPLETE
05	21		LOGICAL BLOCK ADDRESS OUT OF RANGE
05	54		ILLEGAL MODE FOR THIS TRACK
05	63		END OF USER AREA ENCOUNTERED ON THIS TRACK

9.8.11 PLAY AUDIO TRACK RELATIVE (12) Command

The PLAY AUDIO TRACK RELATIVE(12) command requests that the device begin an audio playback operation. The command function and the output of audio signals *shall* be as specified by the settings of the mode parameters including the SOTC bit. See the PLAY AUDIO TRACK RELATIVE (10) command for a description of the fields in this command.

Table 69 - PLAY AUDIO TRACK RELATIVE (12) Command

Bit Byte	7	6	5	4	3	2	1	0
0	Operation Code (A9h)							
1	Reserved							
2	Track Relative Logical Block Address							
3								
4								
5								
6								
6	Transfer Length							
7								
8								
9								
10	Starting Track							
11	Reserved							

This command responds with immediate status, allowing overlapped commands. This command *shall* set the DSC bit upon command completion. See also "9.4 Immediate Command Processing Considerations" on page 68.

Table 70 - Recommended Sense Key, ASC & ASCQ for Play Track Relative (12) Command Errors

Sense Key	ASC	ASCQ	Description of Error
05	20		INVALID COMMAND OPERATION CODE
05	24		INVALID FIELD IN COMMAND PACKET
06	28		NOT READY TO READY TRANSITION
06	29		POWER ON, RESET OR BUS DEVICE RESET OCCURRED
02	04	00	LOGICAL UNIT NOT READY - CAUSE NOT REPORTABLE
02	04	01	LOGICAL UNIT NOT READY - IN PROGRESS OF BECOMING READY
02	04	02	LOGICAL UNIT NOT READY - INITIALIZING COMMAND REQUIRED
02	04	03	LOGICAL UNIT NOT READY - MANUAL INTERVENTION REQUIRED
02	06	00	NO REFERENCE POSITION FOUND (media may be upside down)
02	30	00	INCOMPATIBLE MEDIUM INSTALLED
02	30	01	CANNOT READ MEDIUM - UNKNOWN FORMAT
02	30	02	CANNOT READ MEDIUM - INCOMPATIBLE FORMAT
02	3A		MEDIUM NOT PRESENT
03	02		NO SEEK COMPLETE
05	21		LOGICAL BLOCK ADDRESS OUT OF RANGE
05	54		ILLEGAL MODE FOR THIS TRACK
05	63		END OF USER AREA ENCOUNTERED ON THIS TRACK

See "9.8.7.1 Play Audio with Overlapped Packet Commands" on page 106 for information on overlapped commands during an Audio Playback.

Preliminary Draft
for Review Only

Intentionally Left Blank

9.8.12 PREVENT/ALLOW MEDIUM REMOVAL Command

The PREVENT/ALLOW MEDIUM REMOVAL command requests that the ATAPI CD-ROM Drive enable or disable the removal of the medium. The prevention of media removal (when implemented) *shall* be accomplished through the use of a Locking Mechanism. The locking mechanism is optional and an error *shall* be returned if a command to prevent medium removal is issued (Sense key 05 ILLEGAL REQUEST, Sense Code 24 INVALID FIELD IN COMMAND PACKET).

Table 71 - PREVENT ALLOW MEDIUM REMOVAL Command

Bit Byte	7	6	5	4	3	2	1	0
0	Operation Code (1Eh)							
1	Reserved							
2	Reserved							
3	Reserved							
4	Reserved							Prevent
5	Reserved							
6	Reserved							
7	Reserved							
8	Reserved							
9	Reserved							
10	Reserved							
11	Reserved							

The prevention of medium removal *shall* begin when the Host Computer issues a PREVENT/ALLOW MEDIUM REMOVAL command with a prevent bit of one (medium removal prevented). The prevention of medium removal *shall* terminate:

1. after the Host Computer has issued a PREVENT ALLOW MEDIUM REMOVAL command with a prevent bit of zero (Unlock), and the ATAPI CD-ROM Drive has successfully performed a synchronize cache operation; or
2. upon a hard RESET condition; or
3. if the drive does not support a locking mechanism.

While a prevention of medium removal condition is in effect (Locked) the ATAPI CD-ROM Drive *shall* inhibit mechanisms that normally allow removal of the medium by an operator.

The default state of the drive at power on is unlocked, unless the drive supports a prevent/allow jumper and the jumper is in the prevent state (See "9.8.5.4 CD-ROM Capabilities and Mechanical Status Page" on page 99.)

This command will affect the actions of the START/STOP UNIT command (See "9.8.26 START/STOP UNIT Command" on page 169) and other mechanisms external to this specification (manual ejection / media removal systems.)

Table 72 - Actions for Lock / Unlock / Eject

Operation	Locked / Unlocked	If Drive Not Ready (No Media)	If Drive Ready (Media Present)
Unlock (Prevent = 0)	Unlocked	No Error	No Error
	Locked	No Error, Now media may be inserted	No Error, Now media may be removed
Lock (Prevent = 1)	Unlocked	No Error, Drive door locked and will not allow media to be inserted	No Error, Drive door locked and will not allow media to be removed
	Locked	No Error	No Error
Lock when the drive does not support a Locking Mechanism	Would always be Unlocked	Error: 05 ILLEGAL REQUEST, 24 INVALID FIELD IN COMMAND PACKET	Error: 05 ILLEGAL REQUEST, 24 INVALID FIELD IN COMMAND PACKET
Eject (START/STOP UNIT command with LoEj set)	Unlocked	No Error and Tray is opened	No Error: Media Ejects
	Locked	Error: 02 Not ready, 53 Media Removal Prevented	Error: 02 Not ready, 53 Media Removal Prevented
Manual Eject	Unlocked	Tray opens (If tray exists)	Media is Ejected
	Locked	No operation occurs	No operation, Media stays locked in drive

Table 73 - Recommended Sense Key, ASC and ASCQ for Prevent/Allow Command Errors

Sense Key	ASC	ASCQ	Description of Error
05	20		INVALID COMMAND OPERATION CODE
05	24		INVALID FIELD IN COMMAND PACKET
06	28		NOT READY TO READY TRANSITION
06	29		POWER ON, RESET OR BUS DEVICE RESET OCCURRED
02	04	00	LOGICAL UNIT NOT READY - CAUSE NOT REPORTABLE
02	04	01	LOGICAL UNIT NOT READY - IN PROGRESS OF BECOMING READY
02	04	02	LOGICAL UNIT NOT READY - INITIALIZING COMMAND REQUIRED
02	04	03	LOGICAL UNIT NOT READY - MANUAL INTERVENTION REQUIRED
02	3A		MEDIUM NOT PRESENT
02	53	02	MEDIA REMOVAL PREVENTED

9.8.13 READ (10) Command

The READ (10) command requests that the ATAPI CD-ROM Drive transfer data to the Host Computer. The most recent data value written in the addressed logical block *shall* be returned.

Table 74 - READ (10) Command

Bit Byte	7	6	5	4	3	2	1	0
0	Operation Code (28h)							
1	Reserved							
2	Logical Block Address							
3								
4								
5								
6								
7	Transfer Length							
8								
9	Reserved							
10	Reserved							
11	Reserved							

The Transfer Length field specifies the number of contiguous logical blocks of data that *shall* be transferred. A transfer length of zero indicates that no logical blocks *shall* be transferred. This condition *shall not* be considered an error. Any other value indicates the number of logical blocks that *shall* be transferred.

Although the CD-ROM is capable of returning a variety of data, this command *shall* only return the “User Data” portion of the sector. This field is **always** 2048 bytes in length for Mode 1 and Mode 2 Form 1 sectors, which are the only sector types allowed. For all other sector types, the device *shall* set the ILI bit in the Request Sense Standard Data and return a “CANNOT READ MEDIUM - INCOMPATIBLE FORMAT” error if any read to them using this command is attempted.

Table 75 - Recommended Sense Key, ASC and ASCQ for READ (10) Command Errors

Sense Key	ASC	ASCQ	Description of Error
05	20		INVALID COMMAND OPERATION CODE
05	24		INVALID FIELD IN COMMAND PACKET
06	28		NOT READY TO READY TRANSITION
06	29		POWER ON, RESET OR BUS DEVICE RESET OCCURRED
02	04	00	LOGICAL UNIT NOT READY - CAUSE NOT REPORTABLE
02	04	01	LOGICAL UNIT NOT READY - IN PROGRESS OF BECOMING READY
02	04	02	LOGICAL UNIT NOT READY - INITIALIZING COMMAND REQUIRED
02	04	03	LOGICAL UNIT NOT READY - MANUAL INTERVENTION REQUIRED
02	06	00	NO REFERENCE POSITION FOUND (media may be upside down)
02	30	00	INCOMPATIBLE MEDIUM INSTALLED
02	30	01	CANNOT READ MEDIUM - UNKNOWN FORMAT
02	30	02	CANNOT READ MEDIUM - INCOMPATIBLE FORMAT
02	3A		MEDIUM NOT PRESENT
03	02		NO SEEK COMPLETE
05	21		LOGICAL BLOCK ADDRESS OUT OF RANGE
05	64		ILLEGAL MODE FOR THIS TRACK
03	11	05	L-EC UNCORRECTABLE ERROR
03	11	06	CIRC UNRECOVERED ERROR
01	17	01	RECOVERED DATA WITH RETRIES
01	18	01	RECOVERED DATA WITH ERROR CORRECTION & RETRIES APPLIED
01	18	04	RECOVERED DATA WITH L-EC

9.8.14 READ (12) Command

The READ (12) command requests that the ATAPI CD-ROM Drive transfer data to the Host Computer. The most recent data value written in the addressed logical block *shall* be returned. See "9.8.13 READ (10) Command" on page 117 for a definition of the operation of this command.

Table 76 - READ (12) Command

Bit Byte	7	6	5	4	3	2	1	0
0	Operation Code (A8h)							
1	Reserved							
2	Logical Block Address							
3								
4								
5								
6	Transfer Length							
7								
8								
9								
10	Reserved							
11	Reserved							

Table 77 - Recommended Sense Key, ASC and ASCQ for READ (12) Command Errors

Sense Key	ASC	ASCQ	Description of Error
05	20		INVALID COMMAND OPERATION CODE
05	24		INVALID FIELD IN COMMAND PACKET
06	28		NOT READY TO READY TRANSITION
06	29		POWER ON, RESET OR BUS DEVICE RESET OCCURRED
02	04	00	LOGICAL UNIT NOT READY - CAUSE NOT REPORTABLE
02	04	01	LOGICAL UNIT NOT READY - IN PROGRESS OF BECOMING READY
02	04	02	LOGICAL UNIT NOT READY - INITIALIZING COMMAND REQUIRED
02	04	03	LOGICAL UNIT NOT READY - MANUAL INTERVENTION REQUIRED
02	06	00	NO REFERENCE POSITION FOUND (media may be upside down)
02	30	00	INCOMPATIBLE MEDIUM INSTALLED
02	30	01	CANNOT READ MEDIUM - UNKNOWN FORMAT
02	30	02	CANNOT READ MEDIUM - INCOMPATIBLE FORMAT
02	3A		MEDIUM NOT PRESENT

Table 77 - Recommended Sense Key, ASC and ASCQ for READ (12) Command Errors

Sense Key	ASC	ASCQ	Description of Error
03	02		NO SEEK COMPLETE
05	21		LOGICAL BLOCK ADDRESS OUT OF RANGE
05	64		ILLEGAL MODE FOR THIS TRACK
03	11	05	L-EC UNCORRECTABLE ERROR
03	11	06	CIRC UNRECOVERED ERROR
01	17	01	RECOVERED DATA WITH RETRIES
01	18	01	RECOVERED DATA WITH ERROR CORRECTION & RETRIES APPLIED
01	18	04	RECOVERED DATA WITH L-EC

Preliminary Draft
for Review Only

9.8.15 READ CD-ROM CAPACITY Command

The READ CD-ROM CAPACITY command provides a means for the Host Computer to request information regarding the capacity of the Device. The general function of the CD-ROM version of READ CAPACITY is the same but the exact definition of the returned logical block address is modified to allow returning a possibly inexact value (but one with a known error boundary) based on CD-ROM table of contents data. For many CD-ROM devices, this implementation allows a quicker response.

Table 78 - READ CD-ROM CAPACITY Command

Bit Byte	7	6	5	4	3	2	1	0
0	Operation code (25h)							
1	Reserved							
2	Reserved							
3	Reserved							
4	Reserved							
5	Reserved							
6	Reserved							
7	Reserved							
8	Reserved							
9	Reserved							
10	Reserved							
11	Reserved							

Eight bytes of READ CD-ROM CAPACITY data *shall* be returned to the Host Computer.

Table 79 - READ CAPACITY DATA

Bit Byte	7	6	5	4	3	2	1	0
0	Logical Block Address							
1								
2								
3								
4	Block Length in Bytes							
5								
6								
7								

Table 80 - Recommended Sense Key, ASC and ASCQ for Read Capacity Command Errors

Sense Key	ASC	ASCQ	Description of Error
05	20		INVALID COMMAND OPERATION CODE
05	24		INVALID FIELD IN COMMAND PACKET
06	28		NOT READY TO READY TRANSITION
06	29		POWER ON, RESET OR BUS DEVICE RESET OCCURRED
02	04	00	LOGICAL UNIT NOT READY - CAUSE NOT REPORTABLE
02	04	01	LOGICAL UNIT NOT READY - IN PROGRESS OF BECOMING READY
02	04	02	LOGICAL UNIT NOT READY - INITIALIZING COMMAND REQUIRED
02	04	03	LOGICAL UNIT NOT READY - MANUAL INTERVENTION REQUIRED
02	06	00	NO REFERENCE POSITION FOUND (media may be upside down)
02	30	00	INCOMPATIBLE MEDIUM INSTALLED
02	30	01	CANNOT READ MEDIUM - UNKNOWN FORMAT
02	30	02	CANNOT READ MEDIUM - INCOMPATIBLE FORMAT
02	3A		MEDIUM NOT PRESENT

Preliminary Draft
for Review

9.8.16 READ CD Command

The READ CD command (Family) provides one standard, universal way of accessing CD data. Rather than breaking the types of data into several related commands, this command is generic to all CD data types.

This command returns any of the CD data streams, including the headers, EDC and ECC, ROM data and CD-DA data. Each type of data is enabled via the use of flags. These flags indicate which information from the CD is to be returned in the data stream. If a flag is cleared, then that particular information will not be returned. If all the flags are cleared, no data will be returned to the host and this condition is not treated as an error.

Table 81 - READ CD Command

Bit Byte	7	6	5	4	3	2	1	0
0	Operation Code (BEh)							
1	Reserved			Expected Sector Type			Reserved	
2	Starting Logical Block Address							
3								
4								
5								
6								
7	Flag Bits							
8								
9								
10	Reserved				Sub-Channel Data Selection Bits			
11	Reserved							

The Expected Sector Type field is used to limit the amount of information returned to the Host. If the Requested Sector(s) do not match the specified type, the command will be terminated with a CHECK CONDITION. The Sector that does not match will not be transferred to the Host. The sense key *shall* be set to ILLEGAL MODE FOR THIS TRACK.

Implementer's Note: The Expected Sector Type is used to generate an error and terminate the transfer when the sectors found on the media, do not match the type desired. This field has NO control of the actual number of bytes transfer.

Table 82 - READ-CD, Expected Sector Type Field Definition

Expected Sector Type	Definition	Description
000b	Any Type (Mandatory)	No checking of the Sector Type will be performed. The device <i>shall</i> always terminate a command, at the sector where a transition between CD-Rom and CD-DA occurs.
001b	CD DA (Optional)	Only Red Book (CD-DA) sectors <i>shall</i> be allowed. An attempt to read any other format <i>shall</i> result in the reporting of an error.
010b	Mode 1 Form 1 (Mandatory)	Only Yellow Book sectors which have a "user" data field of 2048 bytes <i>shall</i> be allowed. An attempt to read any other format <i>shall</i> result in the reporting of an error.
011b	Mode 1 Form 2 (Mandatory)	Only Yellow Book sectors which have a "user" data field of 2336 bytes <i>shall</i> be allowed. An attempt to read any other format <i>shall</i> result in the reporting of an error.
100b	Mode 2 Form 1 (Mandatory)	Only Green Book sectors which have a "user" data field of 2048 <i>shall</i> be allowed. An attempt to read any other format <i>shall</i> result in the reporting of an error.
101b	Mode 2 Form 2 (Mandatory)	Only Green Book sectors which have a "user" data field of 2324 <i>shall</i> be allowed. An attempt to read any other format <i>shall</i> result in the reporting of an error. Note that the spare data is included in the user data making the size 2324+4= 2328.
110b - 111b		Reserved

See also, CD-ROM Sector Formats on page 45.

The Synch Field Bit, when set to one indicates that the Synch Field from the sector will be included in the data stream. Note that the data fields that are requested to be included in the data stream *shall* be contiguous. The Synch Field information (if selected) will be the first information in the data stream; all other fields will follow.

The Header(s) Code is an encoded field that indicates the Header / Subheader information to be placed in the data stream.

Table 83 - READ CD, Header Code Field Definition

Header(s) Code	Definition	Description
00b	None	None of the header data <i>shall</i> be placed in the data stream.
01b	HdrOnly	Only the Mode 1 or Form 1 4-byte header will be returned in the data stream.
10b	SubheaderOnly	Only the Mode 2 Form 1 or 2 Subheader will be placed into the data stream.
11b	All Headers	Both the Header and Subheader will be placed in the data stream.

The User Data Flag, when set to one, indicates that the Data part of a CD Sector *shall* be returned in the data stream. When set to 1, the whole user data will be returned to the host. Note that the setting of the Mode Select Density Code does not apply to this command, and the physical user data will be returned. If the current track is an Audio Track then the Audio Data will be returned, else the normal CD-ROM data will be returned. The possible data lengths are 2048, 2336, 2328 and 2352.

The EDC and ECC Flag, when set to one, indicates that the EDC and ECC (L-EC) field *shall* be included in the data

stream. For Mode 1 CDs this will include the 8 bytes of pad data.

Error Flag(s) is an encoded field that indicates which (if any) of the C2 and/or Block Error data will be included in the data stream. All the field types are mandatory. If the drive does not support the C2 pointers (as reported in the Mode sense Capabilities page) the data returned *shall* be zero filled.

Table 84 - READ CD, Error Flag Field Definition

Error Flags	Definition	Description
00b	None	No Error information will be included in the data stream.
01b	C2 Error Flag data	The C2 Error Flag (Pointer) bits (2352 bits or 294 bytes) will be included in the data stream. When the C2 Error pointer bits are included in the data stream, there will be one bit for each byte in error in the sector (2352 total). The bit ordering is from the most significant bit to the least significant bit in each byte. The first bytes in the sector will be the first bits/bytes in the data stream.
10b	C2 & Block Error Flags	Both the C2 Error Flags (2352 bits or 294 bytes) and the Block Error Byte will be included in the data stream. The Block Error byte is just the longitudinal parity of all the C2 Error Flag bytes. So that the data stream will always be an even number of bytes, the Block Error byte will be padded with a 0 byte. The Block Error byte will be first in the data stream followed by the pad byte.
11b	Reserved	Reserved for future enhancement.

The Sub-Channel Data Selection bits indicate which CD Sub-Channel information is to be included in the data stream, the Q information and/or the “Raw” Sub-channel information (All eight channels, one byte from each of the small frames.) If the bit is set, then that Sub-channel data will be included in the data stream to the Host.

Table 85 - READ CD, Sub-channel Data Selection Field Definition

Sub-channel Data Selection	Definition	Description	Type
000b	No Sub-channel Data	No Sub-channel data will be transferred	Mandatory
001b	RAW	Raw Sub-channel data will be transferred	Optional
010b	Q	Q data will be transferred	Mandatory
011b	Reserved		
100b	R - W	R-W data will be transferred	Optional
101b - 111b	Reserved		

Support of Sub-channel data is optional. In the case of R-W the drive may return the data de-interleaved and error-corrected, RAW or padded with zeros depending on the R-W Supported and R-W de-interleaved and error-corrected bits in the CD-ROM capabilities and mechanical status page.

If the Starting Logical Block Address is set to FFFFFFFFh and the **only** information requested to be placed in the data stream is the Sub-channel data and there is currently a PLAY AUDIO command in process, the actual address used will be from the current location (of the Audio play).

Table 86 - Number of Bytes Returned Based on Data Selection Field

	Flag Bits	CD-DA	Mode 1 Form 1	Mode 1 Form 2	Mode 2 Form 1	Mode 2 Form 2
Sync	80h	0	12	12	12	12
Header	20h	0	4	4	4	4
Sync & Header	A0h	0	16	16	16	16
Sub Header	40h	0	0	0	8	8
All Headers	60h	0	4	4	12	12
Sync & Headers	E0h	0	16	16	24	24
User Data	10h	2352	2048	2336	2048	2328
Sub Header & User Data	50h	2352	2048	2336	2056	2336
Header & User Data	30h	2352	2052	2340	2052	2332
All Headers & User Data	70h	2352	2052	2340	2060	2340
Sync & All Headers & User Data	F0h	2352	2064	2352	2072	2352
Repeat All Above and Add EDC / ECC	08h	0	288	0	280	0
Repeat All Above and Add Error Flags	02h	294	294	294	294	294
Repeat All Above and Add Block & Error Flags	04h	296	296	296	296	296

The number of bytes returned is based on which bits are set in the Data Selection Field. The table above allows you to calculate the number of bytes returned based on which Data Selection field bits are set.

Example: A Data Selection field value of 3Ah= 30h+08h+02h would return the following:

- 2352+0+294 bytes for a CD-DA sector.
- 2052+288+294 bytes for a Mode 1 Form 1 sector.
- 2340+0+294 bytes for a Mode 1 Form 2 sector.
- 2052+280+294 bytes for a Mode 2 Form 1 sector.
- 2332+0+294 bytes for a Mode 2 Form 2 sector.

See "Figure 13 - CD-ROM Sector Formats" on page 45 for a description of the data available for each sector type.

Table 87 - Recommended Sense Key, ASC and ASCQ for Read CD Command Errors

Sense Key	ASC	ASCQ	Description of Error
05	20		INVALID COMMAND OPERATION CODE
05	24		INVALID FIELD IN COMMAND PACKET
06	28		NOT READY TO READY TRANSITION
06	29		POWER ON, RESET OR BUS DEVICE RESET OCCURRED
02	04	00	LOGICAL UNIT NOT READY - CAUSE NOT REPORTABLE
02	04	01	LOGICAL UNIT NOT READY - IN PROGRESS OF BECOMING READY
02	04	02	LOGICAL UNIT NOT READY - INITIALIZING COMMAND REQUIRED
02	04	03	LOGICAL UNIT NOT READY - MANUAL INTERVENTION REQUIRED
02	06	00	NO REFERENCE POSITION FOUND (media may be upside down)
02	30	00	INCOMPATIBLE MEDIUM INSTALLED
02	30	01	CANNOT READ MEDIUM - UNKNOWN FORMAT
02	30	02	CANNOT READ MEDIUM - INCOMPATIBLE FORMAT
02	3A		MEDIUM NOT PRESENT
03	02		NO SEEK COMPLETE
05	21		LOGICAL BLOCK ADDRESS OUT OF RANGE
05	54		ILLEGAL MODE FOR THIS TRACK
05	00	11	AUDIO PLAY OPERATION IN PROGRESS
0B	BF		LOSS OF STREAMING

The number of bytes returned is based on which bits are set in the Data Selection Field. The table above allows you to c

The CD-DA audio data includes 16 bits of information for each channel, and will be formatted as follows when an audio track is read.

Table 88 - CD-DA (Digital Audio) Data Block Format

Bit Byte	7	6	5	4	3	2	1	0
Cell 1 (1st of 588)								
0	Left Channel (Lower Byte)							
	b7	b6	b5	b4	b3	b2	b1	b0
1	Left Channel Upper Byte							
	b15	b14	b13	b12	b11	b10	b9	b8
2	Right Channel (Lower Byte)							
	b7	b6	b5	b4	b3	b2	b1	b0
3	Right Channel Upper Byte							
	b15	b14	b13	b12	b11	b10	b9	b8
...								
Cell 588 (last)								

Table 88 - CD-DA (Digital Audio) Data Block Format

Bit Byte	7	6	5	4	3	2	1	0
2348	Left Channel (Lower Byte)							
	b7	b6	b5	b4	b3	b2	b1	b0
2349	Left Channel Upper Byte							
	b15	b14	b13	b12	b11	b10	b9	b8
2350	Right Channel (Lower Byte)							
	b7	b6	b5	b4	b3	b2	b1	b0
2351	Right Channel Upper Byte							
	b15	b14	b13	b12	b11	b10	b9	b8

If the CD-ROM Drive does not support the CD-DA Stream-Is-Accurate capability (See "9.8.5.4 CD-ROM Capabilities and Mechanical Status Page" on page 99) then the Digital Audio data must be read as a continuous stream. If while streaming the drive must stop, there will be a non-recoverable error generated (Sense Key 0Bh ABORTED Command, Sense Code BFh LOSS OF STREAMING). This is due to the 1 second uncertainty of the address (There is no header in CD-DA Data). Reissuing the command may not return exactly the same data as the previous try. When the drive supports the Stream Accurate capability, there will be no error, only some time delay for rotational latency.

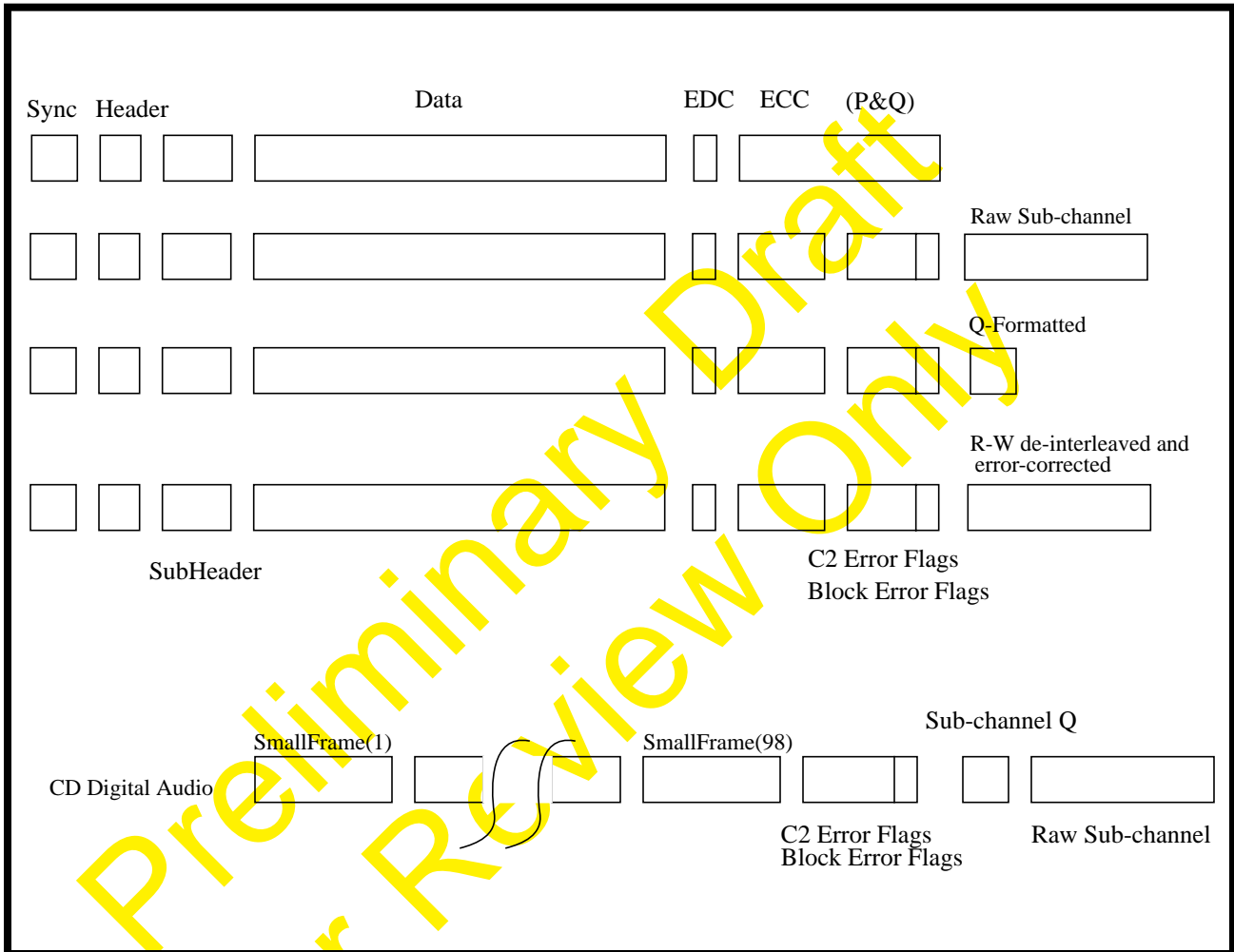

Figure 15 - Read CD Data Stream Order

9.8.16.1 Description of Sub-channels R-W

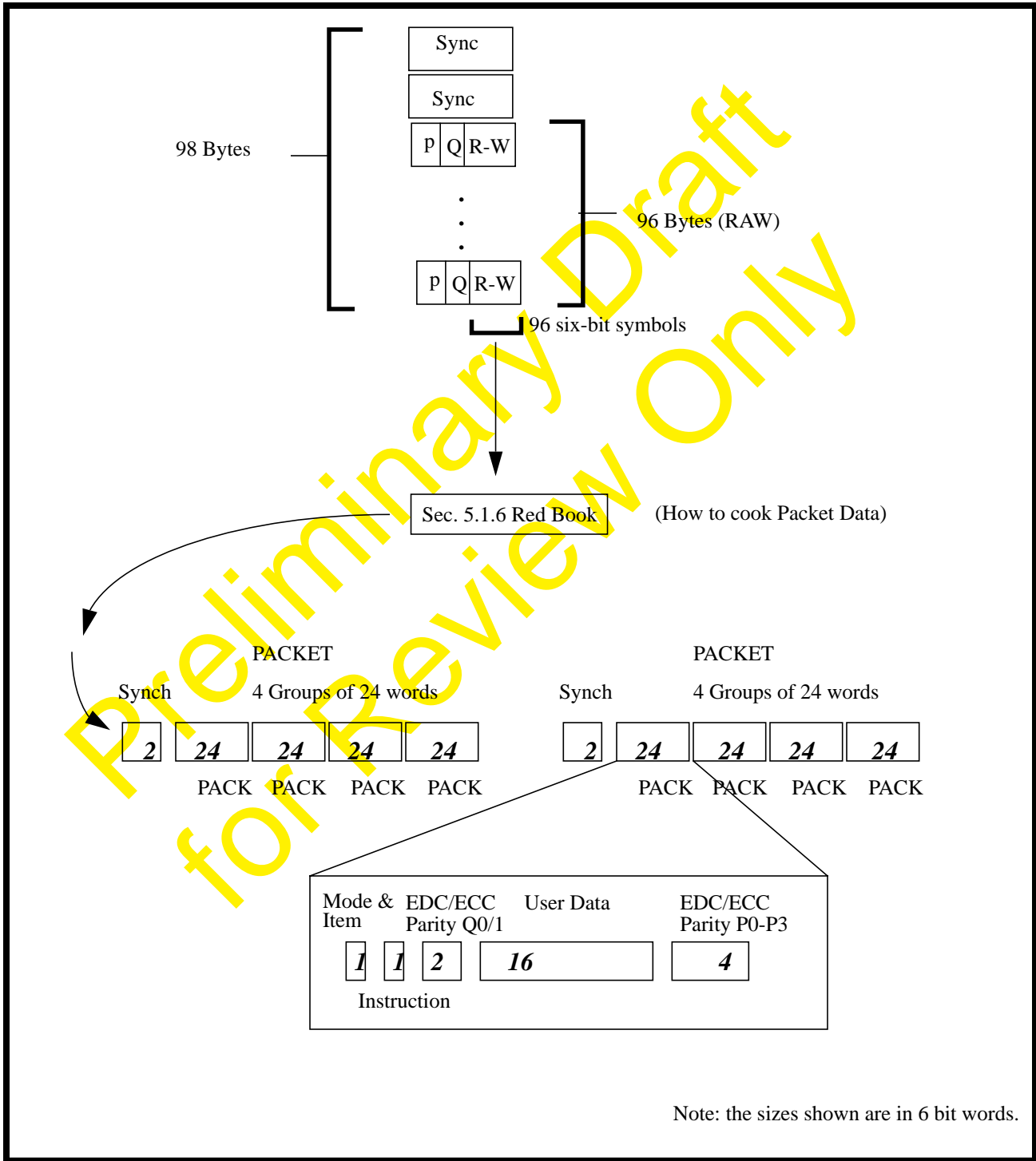

Figure 16 - Read CD Sub-channel, R-W (100b)

Table 89 - R-W Raw

Bit Byte	7	6	5	4	3	2	1	0
0	P2W (0)							
1	P2W (1)							
...	...							
95	P2W (95)							

R-W Raw is returned in the format and order found on the media. It is the responsibility of the device driver to deinterleave and perform error detection and correction on the RAW data to make it usable to higher level applications.

Table 90 - R-W De-Interleaved & Error Corrected

Bit Byte	7	6	5	4	3	2	1	0
0	P	Q	PACK1(0)					
1	P	Q	PACK1(1)					
...	...							
23	P	Q	PACK1(23)					
24	P	Q	PACK2(0)					
25	P	Q	PACK2(1)					
...	...							
47	P	Q	PACK2(23)					
48	P	Q	PACK3(0)					
49	P	Q	PACK3(1)					
...	...							
71	P	Q	PACK3(23)					
72	P	Q	PACK4(0)					
73	P	Q	PACK4(1)					
...	...							
95	P	Q	PACK4(23)					

Drives that can not return P or Q code with PACK data will return 0 in the unsupported P or Q bits. Each PACK is generated after 2 contiguous Sub Channel data frames consisting of 24 bytes with 6 bits of PACK data per byte. Each 96 byte Packet consists of 4 PACKs of 24 bytes each.

The basic RAW format is shown in "Figure 16 - Read CD Sub-channel, R-W (100b)" on page 130. The data is synchronized with the subcode synch patterns S0 and S1. Each group of 6 bits (R-W) is called a "symbol". The symbol following the synchs S0 and S1 is the first symbol of the first pack in a packet.

To guard the data in the subcoding channels R-W, a (24,20) Reed-Solomon Error Correction Code is used. To improve the burst error correction capability, eight-way interleaving is added to this error correction system.

The first two symbols in a pack have additional protection with a (4,2) Read-Solomon Error Correction Code. The first symbol of a pack contains a mode-switch of 3 bits and a 3-bit subdivision of mode, called "item". The defined mode-item

combinations are defined in the following table.

Table 91 - Sub-channel R-W, Allowed Mode/Item Combinations

Mode	Item	Description
000b (0d)	000b (0d)	The ZERO mode
001b (1d)	000b (0d)	The LINE GRAPHICS mode
	001b (1d)	The TV GRAPHICS mode
111b (7d)	000b (0d)	The USER mode
All Others		Reserved for future use

The R-W information is returned as part of the "raw" sub-channel data. The lower 6 bits of each of the bytes contain the R-W data. This data follows the format shown in "Figure 16 - Read CD Sub-channel, R-W (100b)" on page 130. If the Q information needs to be taken from the raw data, then it *shall* be deinterleaved according the Red book formats.

Preliminary Draft
for Review Only

9.8.17 READ CD MSF Command

Table 92 - READ CD MSF Command

Bit Byte	7	6	5	4	3	2	1	0
0	Operation code (D5h)							
1	Reserved			Expected User data type			Reserved	
2	Reserved							
3	Starting M Field							
4	Starting S Field							
5	Starting F Field							
6	Ending M Field							
7	Ending S Field							
8	Ending F Field							
9	Flag Bits							
	Synch Field	Header(s) Code		User Data	EDC & ECC	Reserved for Error Type		Reserved
10	Reserved					Sub-Channel Data Selection Bits		
	Sub Q	Raw	Reserved					
11	Reserved							

The Starting M field, the Starting S field, and the Starting F field specify the absolute MSF address at which the Read operation *shall* begin. The Ending M field, the Ending S field, and the Ending F field specify the absolute MSF address where the Read operation *shall* end. All contiguous sectors between the starting and the ending MSF address *shall* be read.

A starting MSF address equal to an ending MSF address prevents a read operation. This *shall* not be considered an error. If the starting MSF address is greater than the ending MSF address, the command *shall* be terminated with CHECK CONDITION status. The sense key *shall* be set to ILLEGAL REQUEST.

If the starting address is not found, or if a not ready condition exists, the command *shall* be terminated with CHECK CONDITION status.

See "9.8.16 READ CD Command" on page 123 for a description of Expected User Data Type, Flag Bits and Sub-channel Data Selection Bits.

Table 93 - Recommended Sense Key, ASC and ASCQ for Read CD MSF Command Errors

Sense Key	ASC	ASCQ	Description of Error
05	20		INVALID COMMAND OPERATION CODE
05	24		INVALID FIELD IN COMMAND PACKET
06	28		NOT READY TO READY TRANSITION
06	29		POWER ON, RESET OR BUS DEVICE RESET OCCURRED
02	04	01	LOGICAL UNIT IS IN PROCESS OF BECOMING READY
02	06	00	NO REFERENCE POSITION FOUND (media may be upside down)

Table 93 - Recommended Sense Key, ASC and ASCQ for Read CD MSF Command Errors

Sense Key	ASC	ASCQ	Description of Error
02	30	00	INCOMPATIBLE MEDIUM INSTALLED
02	30	01	CANNOT READ MEDIUM - UNKNOWN FORMAT
02	30	02	CANNOT READ MEDIUM - INCOMPATIBLE FORMAT
02	3A		MEDIUM NOT PRESENT
03	02		NO SEEK COMPLETE
05	21		LOGICAL BLOCK ADDRESS OUT OF RANGE
05	00	11	AUDIO PLAY OPERATION IN PROGRESS
05	54		ILLEGAL MODE FOR THIS TRACK

Preliminary Draft
for Review Only

9.8.18 READ HEADER Command

The READ HEADER command requests that the device return the CD-ROM Data Block Address Header of the requested logical block.

Table 94 - READ HEADER Command

Bit Byte	7	6	5	4	3	2	1	0
0	Operation code (44h)							
1	Reserved						MSF	Reserved
2	Logical Block Address							
3								
4								
5								
6								
7	Allocation Length							
8	Reserved							
9								
10								
11								

See "7.6 CD-ROM Address Reporting Formats (MSF bit)" on page 50 for a description of the MSF bit.

The Logical Block Address field specifies the logical block at which the read header operation *shall* begin.

See the READ (10) command for exception handling. If the logical block size is other than the physical block size, it *shall* be mapped into the appropriate physical block from which the data would have been read.

The READ HEADER data format below defines the format for the returned CD-ROM data block address header of the requested logical block.

Table 95 - READ HEADER Data Format

Bit Byte	7	6	5	4	3	2	1	0
0	CD-ROM Data Mode							
1	Reserved							
2	Reserved							
3	Reserved							
4	Absolute CD-ROM Address							
5								
6								
7								

The CD-ROM Data Mode field specifies the CD-ROM data mode of the logical blocks in this sector of data. The values in this field are defined in "Table 96 - CD-ROM Data Mode Codes" on page 136.

Table 96 - CD-ROM Data Mode Codes

CD-ROM Data Mode	User Data Field Contents (2048 Bytes)	Auxiliary Field Contents (288 bytes)
00h	All bytes zero	All bytes zero
01h	User data	L-EC symbols
02h	User data	User data
03h - FFh	Reserved	Reserved

If the MSF bit is zero, the Absolute Address field gives the logical block address of the first logical block in the physical sector where the data for the requested logical block address is found. If the MSF bit is one, the Absolute Address field gives the MSF address of the sector where the data for the requested logical block address is found.

Table 97 - Recommended Sense Key, ASC and ASCQ for Read Header Command Errors

Sense Key	ASC	ASCQ	Description of Error
05	20		INVALID COMMAND OPERATION CODE
05	24		INVALID FIELD IN COMMAND PACKET
06	28		NOT READY TO READY TRANSITION
06	29		POWER ON, RESET OR BUS DEVICE RESET OCCURRED
02	04	00	LOGICAL UNIT NOT READY - CAUSE NOT REPORTABLE
02	04	01	LOGICAL UNIT NOT READY - IN PROGRESS OF BECOMING READY
02	04	02	LOGICAL UNIT NOT READY - INITIALIZING COMMAND REQUIRED
02	04	03	LOGICAL UNIT NOT READY - MANUAL INTERVENTION REQUIRED
02	06	00	NO REFERENCE POSITION FOUND (media may be upside down)
02	30	00	INCOMPATIBLE MEDIUM INSTALLED
02	30	01	CANNOT READ MEDIUM - UNKNOWN FORMAT
02	30	02	CANNOT READ MEDIUM - INCOMPATIBLE FORMAT
02	3A		MEDIUM NOT PRESENT
03	02		NO SEEK COMPLETE
05	21		LOGICAL BLOCK ADDRESS OUT OF RANGE
05	54		ILLEGAL MODE FOR THIS TRACK

9.8.19 READ SUB-CHANNEL Command

The READ SUB-CHANNEL command requests that the ATAPI CD-ROM Drive return the requested sub-channel data plus the state of audio play operations.

Table 98 - READ SUB-CHANNEL Command

Bit Byte	7	6	5	4	3	2	1	0
0	Operation code (42h)							
1	Reserved						MSF (Mandatory)	Reserved
2	Reserved	SubQ (Mandatory)	Reserved					
3	Sub-channel Data Format							
4	Reserved							
5	Reserved							
6	Track Number							
7	Allocation Length							
8								
9	Reserved							
10	Reserved							
11	Reserved							

Sub-channel data returned by this command may be from the last appropriate sector encountered by a current or previous media accessing operation. When there is no current audio play operation, the ATAPI CD-ROM Drive may access the media to read the sub-channel data. The ATAPI CD-ROM Drive is responsible for ensuring that the data returned are current and consistent.

See "7.6 CD-ROM Address Reporting Formats (MSF bit)" on page 50 for a description of the MSF bit. Support for the MSF bit is mandatory.

The sub Q bit set to one requests that the ATAPI CD-ROM Drive return the Q sub-channel data. The sub Q bit set to zero requests that no sub-channel data be returned. This *shall* not be considered an error. Support for the SubQ bit is mandatory. When the sub Q bit is Zero, only the Sub-Channel header is returned.

Table 99 -)Sub-channel Data Format Header

Bit Byte	7	6	5	4	3	2	1	0
Sub Channel Data Header								
0	Reserved							
1	Audio Status							
2	Sub-channel Data Length							
3	Sub-channel Data Length							

The sub-channel data format field specifies the returned sub channel data. If this field is 01h, 02h or 03h, the requested sub-Q data item is returned.

Table 100 - Sub-channel Data Format Codes

Format Code	Returned data	Support Requirement
00h	Reserved	Reserved
01h	CD-ROM current position	Mandatory
02h	Media catalogue number (UPC/bar code)	Mandatory
03h	Track international standard recording code (ISRC)	Mandatory
04h - EFh	Reserved	
F0h - FFh	Vendor-specific	Optional

The track number field specifies the track number from which the ISRC code is transferred. This field *shall* have a value from 01h to 63h (99d), and is valid only when the sub-channel data format is 03h. If this field is nonzero for all sub-channel data formats other than 03h the drive will terminate the command with a check condition (INVALID REQUEST / INVALID FIELD IN COMMAND PACKET).

9.8.19.1 CD-ROM Current Position Data Format

Table 101 - CD-ROM Current Position Data Format (Format Code 01h)

Bit Byte	7	6	5	4	3	2	1	0
Sub Channel Data Header								
0	Reserved							
1	Audio Status							
2	Sub-channel Data Length							
3	Sub-channel Data Length							
CD-ROM Current Position Data Block								

Table 101 - CD-ROM Current Position Data Format (Format Code 01h)

Bit Byte	7	6	5	4	3	2	1	0
4	Sub Channel Data Format Code (01h)							
5	ADR				Control			
6	Track Number							
7	Index Number							
8	Absolute CD-ROM Address							
11								
12	Track Relative CD-ROM Address							
15								

The Audio Status field indicates the status of audio play operations. The audio status values are defined in "Table 102 - Audio Status Codes" on page 139. Audio status values 13h and 14h return information on previous audio operations; they are returned only once after the condition has occurred. If another audio play operation is not requested, the audio status returned for subsequent READ SUB-CHANNEL commands is 15h.

Table 102 - Audio Status Codes

Status	Description
00h	Audio status byte not supported or not valid
11h	Audio play operation in progress
12h	Audio play operation paused
13h	Audio play operation successfully completed
14h	Audio play operation stopped due to error
15h	No current audio status to return

The Sub-channel Data Length specifies the length in bytes of the following sub-channel data block. A sub-channel data length of zero indicates that no sub-channel data block is included in the returned data. Sub-channel data length does not include the sub channel header.

The Sub-Q Channel Data Block consists of control data (bytes 4 - 5), current position data (bytes 6 - 15) and identification data (bytes 16 - 47). The control data and current position data is obtained from the Q sub-channel information of the current block. Identification data may be reported that was obtained from a previous block. If identification data is reported, the data *shall* be valid for the sector addressed by the current position data.

1. If an audio play operation is proceeding in the background, position data for the last sector played *shall* be reported.
2. In other cases, for instance after a READ command, the ATAPI CD-ROM Drive may either report position data for the last sector processed for that operation or may report position data from the sector at the current read head position.

The ADR field gives the type of information encoded in the Q sub-channel of this block, as shown in the following table.

Table 103 - ADR Sub-channel Q Field

ADR code	Description
0h	Sub-channel Q mode information not supplied
1h	Sub-channel Q encodes current position data (i.e. track, index, absolute address, relative address)
2h	Sub-channel Q encodes media catalogue number
3h	Sub-channel Q encodes ISRC
4h - Fh	Reserved

Table 104 - Sub-channel Q Control Bits

Bit	Equals zero	Equals one
0	Audio without pre-emphasis	Audio with pre-emphasis
1	Digital copy prohibited	Digital copy permitted
2	Audio track	Data track
3	Two-channel audio	Four-channel audio

The Track Number field specifies the track from which ISRC data is read. This field must have a value between 01h and 63h and is valid only when the sub-channel data format field is 03h. In this case, the ATAPI CD-ROM Drive returns ISRC data for this track.

The Index Number specifies the index number in the current track.

The Absolute CD-ROM Address field gives the current location relative to the logical beginning of the media. If the MSF bit is zero, this field is a logical block address. If the MSF bit is one, this field is an absolute MSF address.

The Track Relative CD-ROM Address field gives the current location relative to the logical beginning of the current track. If the MSF bit is zero, this field is a track relative logical block address. (If the current block is in the pre-gap area of a track, this will be a negative value, expressed as a twos-complement number.) If the MSF bit is one, this field is the relative MSF address from the Q sub-channel.

9.8.19.2 Media Catalogue Number Data Format

A Media Catalogue Valid (MCVal) bit of one indicates that the media catalogue number field is valid. A MCVal bit of zero indicates that the media catalogue number field is not valid.

The Media Catalogue Number field contains the identifying number of this media according to the uniform product code values (UPC/EAN bar coding) expressed in ASCII. Non-zero values in this field are controlled by the Uniform Product Code Council¹) and the European Article Number Council². A value in this field of all ASCII zeros indicates that the media catalog number is not supplied.

If media catalogue number data is found, the MCVal bit is set to one. If MCN data is not detected, the MCVal bit is set to zero to indicate the Media Catalogue Number field is invalid.

Media catalogue number data returned by this command with sub-channel data format field code 02h may be from any block that has UPC bar code Q sub-channel data. (This code is constant anywhere in every applicable disc.)

The CD-ROM Drive may either return the UPC information that it has previously read (Cached data) or may scan for the information. As the UPC is only guaranteed to be contained in 1 out of 100 sectors and errors may be encountered, the time required to return the UPC data could be several seconds.

Table 105 - Media Catalogue Number Data Format (Format Code 02h)

Bit Byte	7	6	5	4	3	2	1	0
Sub Channel Data Header								
0	Reserved							
1	Audio Status							
2	Sub-channel Data Length							
3								
Media Catalogue Number Data Block								
4	Sub Channel Data Format Code (02h)							
5	Reserved							
6	Reserved							
7	Reserved							
8	MCVal	Reserved						
9	Media Catalogue Number (UPC/Bar Code) (See "Table 106 - UPC Format" on page 142)							
23								

1. The Uniform Product Code Council is located at 8163 Old Yankee Road, Suite J, Dayton, Ohio 45459.
2. The European Article Number Council is located at Rue des Colonies, 54-BTE8, 1000 Brussels, Belgium.

Table 106 - UPC Format

Bit Byte	7	6	5	4	3	2	1	0
8	MCVal	Reserved						
9	N1 (Most significant)							
10	N2							
11	N3							
12	N4							
13	N5							
14	N6							
15	N7							
16	N8							
17	N9							
18	N10							
19	N11							
20	N12							
21	N13							
22	Zero							
23	AFrame (Binary)							

N1 through N13 *shall* be retrieved from the Q channel in mode 2. The data *shall* be encoded as ASCII characters (i.e. if N1 of the UPC is 01bcd, then N1 of the above field *shall* be 49d or 31h).

9.8.19.3 Track International Standard Recording Code Data Format

The Track ISRC field contains the identifying number of this media according to the ISRC standards (DIN-31-621).

Table 107 - Track International Standard Recording Code Data Format

Bit Byte	7	6	5	4	3	2	1	0
Sub Channel Data Header								
0	Reserved							
1	Audio Status							
2	Sub-channel Data Length							
3								
Track ISRC Data Block								
4	Sub Channel Data Format Code (03h)							
5	ADR (03)				Control			
6	Reserved							
7	Reserved							
8	TCVal	Reserved						
9	Track International Standard Recording Code (ISRC							
23)							

If ISRC data is detected, the TCVal bit is set to one. If ISRC data is not detected, the TCVal bit is set to zero to indicate the ISRC field is invalid.

Track ISRC data returned by this command with sub-channel data format field 03h may be from any block in the specified track that has ISRC data. When ADR field is 3 (0011), it is used to assign a unique number to an audio track. This is done by means of the ISRC which is 12 characters long (represented by I1 to I12.) The ISRC can only change immediately after the TNO has been changed.

Table 108 - Raw ISRC Format on the CD-ROM Disc

S0, S1	Control	ADR	I1 I2	I3 I4 I5	00	I6 I7 I8 I9 I10 I11 I12	zero	A Frame	CRC	
		3	ISRC 60 bits							

00: These 2 bits are zero.

zero: These 4 bits are zero.

I1,I2 are the country code; I3,I4,I5 are the owner code; I6,I7 are the year of recording; I8,I9,I10,I11,I12 are the serial number of the recording. The characters from I1 to I5 are coded in a 6-bit format as given below; the characters from I6 to I12 are 4-bit BCD numbers. AFrame is the absolute frame number.

ISRC data returned is encoded as ASCII characters.

Table 109 - ISRC Format of Data Returned to Host

Bit Byte	7	6	5	4	3	2	1	0
8	TCVal	Reserved						
9	Reserved	I1 (Country Code)						
10	Reserved	I2 (A - Z)						
11	Reserved	I3 (Owner Code)						
12	Reserved	I4						
13	Reserved	I5 (A - Z, 0 - 9)						
14	Reserved	1	1	I6 (Year of Recording)				
15	Reserved	1	1	I7				
16	Reserved	1	1	I8 (Serial Number)				
17	Reserved	1	1	I9				
18	Reserved	1	1	I10				
19	Reserved	1	1	I11				
20	Reserved	1	1	I12				
21	Zero							
22	AFrame							
23	Reserved							

Table 110 - Recommended Sense Key, ASC and ASCQ for Read Sub-channel Command Errors

Sense Key	ASC	ASCQ	Description of Error
05	20		INVALID COMMAND OPERATION CODE
05	24		INVALID FIELD IN COMMAND PACKET
06	28		NOT READY TO READY TRANSITION
06	29		POWER ON, RESET OR BUS DEVICE RESET OCCURRED
02	04	00	LOGICAL UNIT NOT READY - CAUSE NOT REPORTABLE
02	04	01	LOGICAL UNIT NOT READY - IN PROGRESS OF BECOMING READY
02	04	02	LOGICAL UNIT NOT READY - INITIALIZING COMMAND REQUIRED
02	04	03	LOGICAL UNIT NOT READY - MANUAL INTERVENTION REQUIRED
02	06	00	NO REFERENCE POSITION FOUND (media may be upside down)
02	30	00	INCOMPATIBLE MEDIUM INSTALLED
02	30	01	CANNOT READ MEDIUM - UNKNOWN FORMAT
02	30	02	CANNOT READ MEDIUM - INCOMPATIBLE FORMAT
02	3A		MEDIUM NOT PRESENT
03	02		NO SEEK COMPLETE
05	21		LOGICAL BLOCK ADDRESS OUT OF RANGE
05	54		ILLEGAL MODE FOR THIS TRACK
05	00	11	AUDIO PLAY OPERATION IN PROGRESS
05	00	12	AUDIO PLAY OPERATION PAUSED
05	00	13	AUDIO PLAY OPERATION SUCCESSFULLY COMPLETED
05	00	14	AUDIO PLAY OPERATION STOPPED DUE TO ERROR
05	00	15	NO CURRENT AUDIO STATUS TO RETURN

9.8.19.4 Caching of Sub-Channel Data

Sub-Channel Q data *shall* be cached by the drive while playing audio. This is necessary so that the Read Sub-Channel or Read CD commands can access the Sub-Channel Q data while executing an immediate command. The device *shall* generate an error if the data is not in the cache.

Read header will return the "Current" data, while Read CD will return the specified data and remove any previous (older) data from the cache.

Using "FFFFFFF" on Read CD will work just like Read Sub-Channel.

9.8.20 READ TOC Command

The READ TOC command requests that the ATAPI CD-ROM Drive transfer data from the table of contents to the Host Computer. Some drives will cache the TOC data and will be able to return it during an Audio play command. Drives that do not cache the data will generate an error and not complete the command.

Table 111 - READ TOC Command

Bit Byte	7	6	5	4	3	2	1	0
0	Operation code (43h)							
1	Reserved						MSF (Mandatory)	Reserved
2	Reserved							
3	Reserved							
4	Reserved							
5	Reserved							
6	Starting Track / Session Number							
7	Allocation Length							
8								
9	Format		Reserved					
10	Reserved							
11	Reserved							

See "7.6 CD-ROM Address Reporting Formats (MSF bit)" on page 50 for a description of the MSF bit. Support for the MSF bit is mandatory.

To identify the multi-session CD TOC, the most significant 2 bits of the byte at offset 9 (Format) have been assigned to identify this information. For handling multi-session and/or the Kodak PhotoCD, format 01b can be used. For drives that do not support multi-session, the First session number should be equal to the Last session number in the returned TOC information. Format field definition:

- 00b Mandatory This mode is a backward compatible mode where the starting track field specifies the starting track number for which the data *shall* be returned. If this value is zero, the table of contents data *shall* begin with the first track on the medium. The data are returned in contiguous ascending track number order.
- 01b Mandatory Multi-session mode and returns the first session number, last session number and last session address. In this format the Starting Track is reserved and must be zero. The allocation length must be 10 (0Ah) bytes.
- 10b Mandatory Returns all Sub-channel Q data in the lead in (TOC) area, starting from a specified session number as specified in the Session Number Field. In this mode, the drive will support Q Subcode Point field values of A0h, A1h, A2h; Track Numbers of B0h, B1h, B2h, B3h, B4h and C0h.
- 11b Reserved

The Starting Track Field specifies the starting track number for which the TOC data will be returned. The data is returned in contiguous ascending order. Valid values for the starting track field are 0h to 63h. A value of AAh requests that the starting address of the lead out area be returned. If this value is zero, the table of contents data will begin with the first track on the disc.

If the starting track field is not valid for the currently installed medium, the command *shall* be terminated with CHECK CONDITION status. The sense key *shall* be set to ILLEGAL REQUEST and the additional sense code set to INVALID FIELD IN COMMAND PACKET.

NOTE The maximum TOC data length possible on currently available CD-ROM media is 804 bytes, or 100 TOC track descriptors.

Table 112 - Read TOC Data Format (With Format Field = 00b)

Bit Byte	7	6	5	4	3	2	1	0
0	TOC Data Length							
1								
2	First Track Number							
3	Last Track Number							
TOC Track Descriptors								
0	Reserved							
1	ADR				Control			
2	Track Number							
3	Reserved							
4	Absolute CD-ROM Address							
7								

The TOC Data Block contains a four-byte header followed by zero or more TOC track descriptors.

The TOC Data Length specifies the length in bytes of the following TOC data that is available to be transferred to the Host. The TOC Data Length Value does not include the TOC Data Length field itself.

The First Track Number field indicates the first track number in the table of contents. Valid track numbers are from 01d to 99d (63h).

The Last Track Number field indicates the last track number in the table of contents before the lead-out track number.

The First Track Number is not required to be one. A disc may start at any valid track number. The track numbers between the First Track Number and the Last Track Number are required to be in contiguous ascending order, except for the lead-out track.

The ADR field gives the type of information encoded in the Q sub-channel of the block where this TOC entry was found. The possible ADR values are defined in "Table 103 - ADR Sub-channel Q Field" on page 140.

The Control field indicates the attributes of the track. The possible Control field values are defined in "Table 118 - Values for Control Field in Sub-channel Q" on page 150.

The Track Number field indicates the track number for which the data in the TOC track descriptor is valid. A track number of 0AAh indicates that the track descriptor is for the start of the lead-out area.

The Absolute CD-ROM Address contains the address of the first block with user information for that track number as read from the table of contents. If the MSF bit in the READ TOC is zero, the absolute CD-ROM address field contains a logical block address. If the MSF bit is one, the absolute CD-ROM address field contains an MSF address.

The Starting Logical Block Address Value recovered from the TOC has a tolerance of zero for data tracks and plus or minus 75 CD sectors for audio tracks. This tolerance is multiplied by a factor dependent on the logical block length.

Table 113 - Read TOC Data Format (With Format Field = 01b)

Bit Byte	7	6	5	4	3	2	1	0
0	TOC Data Length (0Ah)							
1								
2	First Session Number							
3	Last Session Number							
TOC Track Descriptors								
0	Reserved							
1	ADR				Control			
2	First Track Number in Last Session							
3	Reserved							
4	Absolute CD-ROM Address of First Track in Last Session							
7								

For Format field 10b, the drive should return TOC data for Q-subcode mode (ADR field) 1 and 5 (Except mode 5, point 1 through 40) in the lead in area.

The First Session Number is equal to the Last Session Number for single session discs or if the drive does not support multi-session discs.

The returned TOC data of a multi-session disc is arranged in ascending order of the session number. The TOC data within a session is arranged in the order of Q Subcode Point Field value of A0h, A1h, A2h; Track Numbers B0h, B1h, B2h, B3h, B4h and C0h.

Table 114 - Read TOC Data Format (With Format Field = 10b)

Bit Byte	7	6	5	4	3	2	1	0
0	TOC Data Length							
1								
2	First Session Number							
3	Last Session Number							
TOC Track Descriptors								
0	Session Number							
1	ADR				Control			
2	Byte 1 or TNO							
3	Byte 2 or Point							
4	Byte 3 or Min							
5	Byte 4 or Sec							
6	Byte 5 or Frame							
7	Byte 6 or Zero							
8	Byte 7 or PMin							
9	Byte 8 or PSec							
10	Byte 9 or PFrame							

See Table 116, "Lead in Area (TOC), Sub-channel Q formats," on page 149 and section 9.8.20.2 on page 151 for a detailed description of bytes 2-10 above.

Table 115 - Recommended Sense Key, ASC and ASCQ for Read TOC Command Errors

Sense Key	ASC	ASCQ	Description of Error
05	20		INVALID COMMAND OPERATION CODE
05	24		INVALID FIELD IN COMMAND PACKET
06	28		NOT READY TO READY TRANSITION
06	29		POWER ON, RESET OR BUS DEVICE RESET OCCURRED
02	04	00	LOGICAL UNIT NOT READY - CAUSE NOT REPORTABLE
02	04	01	LOGICAL UNIT NOT READY - IN PROGRESS OF BECOMING READY
02	04	02	LOGICAL UNIT NOT READY - INITIALIZING COMMAND REQUIRED
02	04	03	LOGICAL UNIT NOT READY - MANUAL INTERVENTION REQUIRED
02	06	00	NO REFERENCE POSITION FOUND (media may be upside down)
02	30	00	INCOMPATIBLE MEDIUM INSTALLED
02	30	01	CANNOT READ MEDIUM - UNKNOWN FORMAT
02	30	02	CANNOT READ MEDIUM - INCOMPATIBLE FORMAT
02	3A		MEDIUM NOT PRESENT
02	57		UNABLE TO RECOVER TABLE OF CONTENTS
05	00	11	AUDIO PLAY OPERATION IN PROGRESS

9.8.20.1 Sub-channel Q TOC information

Table 116 - Lead in Area (TOC), Sub-channel Q formats

S0,S1	Control / ADR	TNO	Point	Min	Sec	Frame	Zero	Pmin	Psec	PFrame	CRC x16+x12+x5+1
4/6	1	00	01-99	ATIP (Absolute time in pre-groove)			00	Start position of track			
4/6	1	00	A0	ATIP (Absolute time in pre-groove)			00	First Track num	Disc Type	00	
4/6	1	00	A1	ATIP (Absolute time in pre-groove)			00	Last Track num	00	00	
4/6	1	00	A2	ATIP (Absolute time in pre-groove)			00	Start position of the Lead-out area			
4/6	5	00	B0	Start time of next possible program in the Recordable Area of the Hybrid Disc			# of pointers in Mode 5	Maximum start time of the outermost Lead Out area in the Recordable Area of the Hybrid Disc			
4/6	5	00	B1	00	00	00	00	# of Skip Interval Pointers (N<=40)	# of Skip Track Pointers (N<=21)	00	
4/6	5	00	B2-B4	Skip #	Skip #	Skip #	Skip #	Skip #	Skip #	Skip #	
4/6	5	00	01-40	Ending time for the interval that should be skipped			Reserved	Start time for interval that should be skipped on playback			
4/6	5	00	C0	Optimum recording power	Application Code	Reserved	Reserved	Start time of the first Lead In Area of the Hybrid Disc			

Point

The Point field defines various types of information:

- 01-99 Track number references
- A0 First Track number in the program area
- A1 Last Track number in the program area
- A2 Start location of the Lead-out area
- B0 Used to identify a Hybrid Disc (Photo CD)
Contains start time of next possible program area
- B1 Number of Skip Interval Pointers & Skip Track assignments
- 01-40 Skip Interval Pointers
- B2-B4 Skip Track Assignment Pointers
- C0 Start time of first Lead In area of Hybrid Disc
This only exists in the first Lead In area

Disc Type Byte

This byte contains a definition of the type of disc

- 00h CD-DA or CD-ROM with first track in Mode 1
- 10h CD-I disc
- 20h CD-ROM XA disc with first track in Mode 2

Table 117 - Bit Definitions for the Control Field in Sub-channel Q

Control Field	Definition
0 0 x 0	2 Audio without Pre-emphasis
0 0 x 1	2 Audio with Pre-emphasis
0 x 0 x	Copy Prohibited
0 x 1 x	Copy Permitted
0 1 x 0	Digital Data
1 x x x	Broadcast Data (TBD)

Table 118 - Values for Control Field in Sub-channel Q

Control Field value	Description
00h	Copy Prohibited, 2 Audio with out pre-emphasis
01h	Copy Prohibited, 2 Audio with pre-emphasis
02h	Copy Permitted, 2 Audio with out pre-emphasis
03h	Copy Permitted, 2 Audio with pre-emphasis
04h	Copy Prohibited, Digital Data
05h	Copy Prohibited, RESERVED
06h	Copy Permitted, Digital Data
07h	Copy Permitted, RESERVED
08h - 0Fh	Broadcast use

9.8.20.2 Example Read TOC Operations

The following example is based on a 4-session, 12-track PhotoCD disc. Data structure is shown as the data to Host.

Command Packet: 43h 00 00 00 00 00 00 10h 00 80h 00 00

Table 119 - Example Read TOC Operations

Ses	A/C	TNO	Pnt	Min Sec Frame	Zero	PMin PSec PFrame	Comments
01	14	00	A0	00 00 00	00	01 20 00	First track is 1. XA disc
01	14	00	A1	00 00 00	00	03 00 00	Last track is 3
01	14	00	A2	00 00 00	00	02 08 3F	Lead Out Area on 1st session
01	14	00	01	00 00 00	00	00 02 00	Start address of track 1
01	14	00	02	00 00 00	00	00 08 02	Start address of track 2
01	14	00	03	00 00 00	00	00 15 32	Start address of track 3
01	54	00	B0	04 26 3F	02	40 02 00	Next recordable area address
01	54	00	C0	C0 00 00	00	61 2C 00	Hybrid disc
02	14	00	A0	00 00 00	00	04 14 00	1st track on 2nd session is 4
02	14	00	A1	00 00 00	00	06 00 00	Last track on 2nd session is 6
02	14	00	A2	00 00 0	00	08 20 08	Lead Out Area on 2nd session
02	14	00	04	00 00 00	00	04 28 3F	Start address of track 4
02	14	00	05	00 00 00	00	04 2E 41	Start address of track 5
02	14	00	06	00 00 00	00	06 27 36	Start address of track 6
02	54	00	B0	09 2C 08	01	40 02 00	Next recordable area address
03	14	00	A0	00 00 00	00	07 14 00	1st track on 3rd session is 7
03	14	00	A1	00 00 00	00	09 00 00	Last track on 3rd session is 9
03	14	00	A2	00 00 00	00	0C 27 32	Lead Out Area on 3rd session
03	14	00	07	00 00 00	00	09 2E 08	Start address of track 7
03	14	00	08	00 00 00	00	09 34 10	Start address of track 8
03	14	00	09	00 00 00	00	0B 04 24	Start address of track 9
03	54	00	B0	20 09 32	01	40 02 00	Next recordable area address
04	14	00	A0	00 00 00	00	0A 14 00	1st track on 4th session is 10
04	14	00	A1	00 00 00	00	0C 00 00	Last track on 4th session is 12
04	14	00	A2	00 00 00	00	12 1B 1A	Lead Out Area on 4th session
04	14	00	10	00 00 00	00	0E 0B 32	Start address of track 10
04	14	00	11	00 00 0	00	0E 11 34	Start address of track 11
04	14	00	12	00 00 00	00	11 08 22	Start address of track 12
04	54	00	B0	13 39 1A	01	40 02 00	Next recordable area address

Ses: session number
A/C: ADR/Control
TNO: 00 for Lead In area
Pnt: POINT

If you use following command on this disc, Command Packet: 43h 00 00 00 00 00 01h 10h 00 40h 00 00
return data would be:

TOC Data Length: 0Ah
First Session Number: 01h
Last Session Number: 04h

Reserved:	00h
ADR/Control:	14h
First Track Number in Last session:	0Ah (10d)
Reserved:	00h
Absolute CD-ROM address of first track in last session:	00h,00h,F8h,EDh (In LBA format, 63725.) -> 14M 9S 50F -> add 2 sec: 14M 11S 50F

Preliminary Draft
for Review Only

9.8.21 REQUEST SENSE Command

The REQUEST SENSE command requests that the ATAPI CD-ROM Drive transfer sense data to the Host Computer.

Table 120 - Request Sense Command

Bit Byte	7	6	5	4	3	2	1	0
0	Operation code (03h)							
1	Reserved							
2	Reserved							
3	Reserved							
4	Allocation Length							
5	Reserved							
6	Reserved							
7	Reserved							
8	Reserved							
9	Reserved							
10	Reserved							
11	Reserved							

The sense data:

1. *shall* be available if an error condition (CHECK CONDITION) had previously been reported to the Host Computer;
2. *shall* be available if other information (e.g. medium position) is available in any field.

If the ATAPI CD-ROM Drive has no other sense data available to return, it *shall* return a sense key of NO SENSE and an additional sense code of NO ADDITIONAL SENSE INFORMATION.

The sense data *shall* be preserved by the ATAPI CD-ROM Drive until retrieved by a REQUEST SENSE command or until the receipt of any other I/O Command.

The ATAPI CD-ROM Drive *shall* return CHECK CONDITION status for a REQUEST SENSE command only to report exception conditions specific to the command itself. For example:

1. A non-zero reserved bit is detected in the Command Packet;
2. An ATAPI CD-ROM Drive malfunction prevents return of the sense data.

If a recovered error occurs during the execution of the REQUEST SENSE command, the ATAPI CD-ROM Drive *shall* return the sense data with GOOD status. If an ATAPI CD-ROM Drive returns CHECK CONDITION status for a REQUEST SENSE command, the sense data may be invalid.

ATAPI CD-ROM Drives *shall* be capable of returning at least 18 bytes of data in response to a REQUEST SENSE command. If the allocation length is 18 or greater, and an ATAPI CD-ROM Drive returns less than 18 bytes of data, the Host Computer should assume that the bytes not transferred would have been zeros had the ATAPI CD-ROM Drive returned those bytes. Host Computers can determine how much sense data has been returned by examining the allocation length parameter in the Command Packet and the additional sense length in the sense data. ATAPI CD-ROM Drives *shall* not adjust the additional sense length to reflect truncation if the allocation length is less than the sense data available.

The sense data format for error codes 70h (current errors) and 71h (deferred errors) are defined in "Table 121 - Request Sense Standard Data" on page 154. Error code values of 72h to 7Eh are reserved. Error code 7Fh is for a vendor-specific sense data format. ATAPI CD-ROM Drives *shall* implement error code 70h; implementation of error code 71h is optional. Error code values of 00h to 6Fh are not defined by this Specification and their use is not recommended.

Table 121 - Request Sense Standard Data

Bit Byte	7	6	5	4	3	2	1	0
0	Valid	Error Code (70h or 71h)						
1	Segment Number (Reserved)							
2	Reserved	ILI	Reserved	Sense Key				
3	Information							
6								
7	Additional Sense Length (n - 7)							
8	Command Specific Information							
11	Additional Sense Code							
12								
13	Additional Sense Code Qualifier (Optional)							
14	Field Replaceable Unit Code (Optional)							
15	SKSV (Optional)	Sense Key Specific (Optional)						
17	Additional Sense Bytes							
18								
n								

A Valid bit of zero indicates that the information field is not as defined in this Specification. A Valid bit of one indicates the information field contains valid information as defined in this Specification. ATAPI CD-ROM Drives *shall* implement the Valid bit.

The Segment Number field is Reserved.

An Incorrect Length Indicator (ILI) bit of one indicates that the requested allocation length did not match the logical block length of the data on the medium.

The Sense Key, Additional Sense Code and Additional Sense Code Qualifier provide a hierarchy of information. The intention of the hierarchy is to provide a top-down approach for a Host Computer to determine information relating to the error and exception conditions. The Sense Key provides generic categories in which error and exception conditions can be reported. Host Computers would typically use sense keys for high-level error recovery procedures. Additional Sense Codes provide further detail describing the sense key. Additional Sense Code Qualifiers add further detail to the additional sense code. The Additional Sense Code and Additional Sense Code Qualifier can be used by Host Computers where sophisticated error recovery procedures require detailed information describing the error and exception conditions.

The Sense Key field is mandatory and indicates generic information describing an error or exception condition. The sense keys are defined in section Table 124 -, "Sense Key Descriptions", on page 157.

The contents of the Information field is command-specific and is defined within the appropriate section for the command of interest. ATAPI CD-ROM Drives *shall* implement the Information field. Unless specified otherwise, this field contains the unsigned logical block address associated with the sense key.

The Additional Sense Length field indicates the number of additional sense bytes to follow. If the allocation length of the Command Packet is too small to transfer all of the additional sense bytes, the Additional Sense Length is not adjusted to

reflect the truncation.

The Command-specific Information field contains information that depends on the command that was executed. Further meaning for this field is defined within the command description.

The Additional Sense Code (ASC) field indicates further information related to the error or exception condition reported in the Sense Key field. ATAPI CD-ROM Drives *shall* support the Additional Sense Code field. Support of the additional sense codes not explicitly required by this Specification is optional. A list of additional sense codes is in "Table 125 - ASC and ASCQ Assignments" on page 158. If the ATAPI CD-ROM Drive does not have further information related to the error or exception condition, the Additional Sense Code is set to NO ADDITIONAL SENSE INFORMATION.

The Additional Sense Code Qualifier (ASCQ) indicates detailed information related to the Additional Sense Code. The ASCQ is optional. If the error or exception condition is reportable by the device, the value returned *shall* be as specified in "Table 125 - ASC and ASCQ Assignments" on page 158. If the ATAPI CD-ROM Drive does not have detailed information related to the error or exception condition, the ASCQ is set to zero.

Non-zero values in the Field Replaceable Unit Code field are used to define a device-specific mechanism or unit that has failed. A value of zero in this field *shall* indicate that no specific mechanism or unit has been identified to have failed or that the data is not available. The Field Replaceable Unit Code field is optional. The format of this information is not specified by this Specification. Additional information about the field replaceable unit may be available in the ASCII information page, if supported by the ATAPI CD-ROM Drive.

The Additional Sense Bytes field may contain command specific data, peripheral device specific data, or vendor-specific data that further defines the nature of the CHECK CONDITION status.

9.8.21.1 Sense-key Specific

The Sense-key Specific field is defined by this Specification when the value of the Sense-key Specific Valid (SKSV) bit is one. The Sense-key Specific Valid bit and Sense-key Specific field are optional. The definition of this field is determined by the value of the sense key field. This field is reserved for sense keys not described below. An SKSV value of zero indicates that this field is not as defined by this Specification.

If the Sense Key field is set to ILLEGAL REQUEST and the SKSV bit is set to one, the Sense-key Specific field indicates which illegal parameters in the Command Packet or the data parameters are in error.

Table 122 - Field Pointer Bytes

Bit Byte	7	6	5	4	3	2	1	0
15	SKSV	C/D	Reserved	Reserved	BPV	Bit Pointer		
16	Field Pointer							
17								

A Command Data (C/D) bit of one indicates that the illegal parameter is in the Command Packet. A C/D bit of zero indicates that the illegal parameter is in the data parameters sent by the Host Computer.

A Bit Pointer Valid (BPV) bit of zero indicates that the value in the Bit Pointer field is not valid. A BPV bit of one indicates that the Bit Pointer field specifies which bit of the byte designated by the field pointer field is in error. When a multiple-bit field is in error, the Bit Pointer field *shall* point to the most-significant (left-most) bit of the field.

The Field Pointer field indicates which byte of the Command Packet or of the parameter data was in error. Bytes are

numbered starting from zero, as shown in the tables describing the commands and parameters. When a multiple-byte field is in error, the pointer *shall* point to the most significant (left-most) byte of the field.

If the sense key is RECOVERED ERROR, HARDWARE ERROR or MEDIUM ERROR and if the SKSV bit is one, the sense-key specific field *shall* be as shown in "Table 123 - Field Pointer Bytes" on page 156.

Table 123 - Field Pointer Bytes

Bit Byte	7	6	5	4	3	2	1	0
15	SKSV	C/D	Reserved	Reserved	BPV	Bit Pointer		
16	Actual Retry Count							
17								

The Actual Retry Count field returns implementation-specific information on the actual number of retries of the recovery algorithm used in attempting to recover an error or exception condition. This field should relate to the retry count fields within the Error Recovery Page of the MODE SELECT command.

9.8.21.2 Deferred Errors

Error code 70h indicates that the CHECK CONDITION status returned is the result of an error or exception condition on the I/O process that returned the CHECK CONDITION status. This includes errors generated during execution of the command by the actual execution process. It also includes errors not related to any command that are first observed during execution of a command. Examples of this latter type of error include disk servo-mechanism, off-track errors, and power-up test errors.

Error code 71h (deferred error) indicates that the CHECK CONDITION status returned is the result of an error or exception condition that occurred during execution of a previous command for which GOOD status has already been returned. Such commands are associated with use of the immediate bit, with some forms of caching, and with multiple command buffering. ATAPI CD-ROM Drives that implement these features are required to implement deferred error reporting.

The deferred error may be indicated by returning CHECK CONDITION status to the Host Computer as described below. The subsequent execution of a REQUEST SENSE command *shall* return the deferred error sense information.

If an I/O Command terminates with CHECK CONDITION status and the subsequent sense data returns a deferred error, that I/O command *shall not* have been executed. After the ATAPI CD-ROM Drive detects a deferred error condition on a Device, it *shall* return a deferred error according to the rules described below:

1. If a deferred error can be recovered with no external system intervention, a deferred error indication *shall* not be posted unless required by the error handling parameters of the MODE SELECT command. The occurrence of the error may be logged if statistical or error logging is supported.
2. If a deferred error can be associated with a particular function or a particular subset of data, and the error is either unrecovered or required to be reported by the mode parameters, a deferred error indication *shall* be returned to the Host Computer.

Deferred errors may indicate that an operation was unsuccessful long after the command performing the data transfer returned GOOD status. If data that cannot be replicated or recovered from other sources is being stored using buffered write operations, synchronization commands should be performed before the critical data is destroyed in the host Host Computer. This is necessary to be sure that recovery actions can be taken if deferred errors do occur in the storing of the data.

9.8.21.3 Sense-key and Sense Code Definitions

Table 124 - Sense Key Descriptions

Sense key	Description
0h	NO SENSE. Indicates that there is no specific sense key information to be reported. This would be the case for a successful command.
1h	RECOVERED ERROR. Indicates that the last command completed successfully with some recovery action performed by the ATAPI CD-ROM Drive. Details may be determinable by examining the additional sense bytes and the information field. When multiple recovered errors occur during one command, the choice of which error to report (first, last, most severe, etc.) is device specific.
2h	NOT READY. Indicates that the Device cannot be accessed. Operator intervention may be required to correct this condition.
3h	MEDIUM ERROR. Indicates that the command terminated with a non-recovered error condition that was probably caused by a flaw in the medium or an error in the recorded data. This sense key may also be returned if the ATAPI CD-ROM Drive is unable to distinguish between a flaw in the medium and a specific hardware failure (sense key 4h).
4h	HARDWARE ERROR. Indicates that the ATAPI CD-ROM Drive detected a non-recoverable hardware failure (for example, controller failure, device failure, parity error, etc.) while performing the command or during a self test.
5h	ILLEGAL REQUEST. Indicates that there was an illegal parameter in the Command Packet or in the additional parameters supplied as data for some commands. If the ATAPI CD-ROM Drive detects an invalid parameter in the Command Packet, then it <i>shall</i> terminate the command without altering the medium. If the ATAPI CD-ROM Drive detects an invalid parameter in the additional parameters supplied as data, then the ATAPI CD-ROM Drive may have already altered the medium.
6h	UNIT ATTENTION. Indicates that the removable medium may have been changed or the ATAPI CD-ROM Drive has been reset.
7h	DATA PROTECT. Indicates that a command that reads the medium was attempted on a block that is protected from this operation. The read operation is not performed.
8h	Reserved
9h - Ah	Reserved
Bh	ABORTED COMMAND. Indicates that the device has aborted the command. The Host may be able to recover by trying the command again. This error is reported for conditions such as an overrun etc.
Eh	MISCOMPARE. Indicates that the source data did not match the data read from the medium.
Fh	Reserved

9.8.21.4 Using the REQUEST SENSE Command

Whenever an Error is reported, the Host Computer should issue a REQUEST SENSE command to receive the sense data describing what caused the Error condition. If the Host Computer issues some other command, the sense data is lost.

		D - DIRECT ACCESS DEVICE	
		R - READ ONLY (CD-ROM) DEVICE	
		O - OPTICAL MEMORY DEVICE	
		M - MEDIA CHANGER DEVICE	
ASC	ASCQ	DROM	DESCRIPTION
00	00	DROM	NO ADDITIONAL SENSE INFORMATION
00	11	R	AUDIO PLAY OPERATION IN PROGRESS
00	12	R	AUDIO PLAY OPERATION PAUSED
00	13	R	AUDIO PLAY OPERATION SUCCESSFULLY COMPLETED
00	14	R	AUDIO PLAY OPERATION STOPPED DUE TO ERROR
00	15	R	NO CURRENT AUDIO STATUS TO RETURN
02	00	DROM	NO SEEK COMPLETE
04	00	DROM	LOGICAL UNIT NOT READY - CAUSE NOT REPORTABLE
04	01	DROM	LOGICAL UNIT NOT READY - IN PROGRESS OF BECOMING READY
04	02	DROM	LOGICAL UNIT NOT READY - INITIALIZING COMMAND REQUIRED
04	03	DROM	LOGICAL UNIT NOT READY - MANUAL INTERVENTION REQUIRED
06	00	DROM	NO REFERENCE POSITION FOUND
09	00	DRO	TRACK FOLLOWING ERROR
09	01	RO	TRACKING SERVO FAILURE
09	02	RO	FOCUS SERVO FAILURE
09	03	RO	SPINDLE SERVO FAILURE
11	00	DRO	UNRECOVERED READ ERROR
11	06	RO	CIRC UNRECOVERED ERROR
15	00	DROM	RANDOM POSITIONING ERROR
15	01	DROM	MECHANICAL POSITIONING ERROR
15	02	DRO	POSITIONING ERROR DETECTED BY READ OF MEDIUM
17	00	DRO	RECOVERED DATA WITH NO ERROR CORRECTION APPLIED
17	01	DRO	RECOVERED DATA WITH RETRIES
17	02	DRO	RECOVERED DATA WITH POSITIVE HEAD OFFSET
17	03	DRO	RECOVERED DATA WITH NEGATIVE HEAD OFFSET
17	04	RO	RECOVERED DATA WITH RETRIES AND/OR CIRC APPLIED
17	05	DRO	RECOVERED DATA USING PREVIOUS SECTOR ID
18	00	DRO	RECOVERED DATA WITH ERROR CORRECTION APPLIED
18	01	DRO	RECOVERED DATA WITH ERROR CORRECTION & RETRIES APPLIED
18	02	DRO	RECOVERED DATA - THE DATA WAS AUTO-REALLOCATED
18	03	R	RECOVERED DATA WITH CIRC
18	04	R	RECOVERED DATA WITH L-EC
18	05	DRO	RECOVERED DATA - RECOMMEND REASSIGNMENT
18	06	DRO	RECOVERED DATA - RECOMMEND REWRITE
1A	00	DROM	PARAMETER LIST LENGTH ERROR
20	00	DROM	INVALID COMMAND OPERATION CODE
21	00	DROM	LOGICAL BLOCK ADDRESS OUT OF RANGE
24	00	DROM	INVALID FIELD IN COMMAND PACKET
26	00	DROM	INVALID FIELD IN PARAMETER LIST
26	01	DROM	PARAMETER NOT SUPPORTED
26	02	DROM	PARAMETER VALUE INVALID

Table 125 - ASC and ASCQ Assignments

ASC	ASCQ	DROM	DESCRIPTION
26	03	DROM	THRESHOLD PARAMETERS NOT SUPPORTED
28	00	DROM	NOT READY TO READY TRANSITION, MEDIUM MAY HAVE CHANGED
29	00	DROM	POWER ON, RESET OR BUS DEVICE RESET OCCURRED
2A	00	DROM	PARAMETERS CHANGED
2A	01	DROM	MODE PARAMETERS CHANGED
30	00	DROM	INCOMPATIBLE MEDIUM INSTALLED
30	02	DRO	CANNOT READ MEDIUM - INCOMPATIBLE FORMAT
30	01	DRO	CANNOT READ MEDIUM - UNKNOWN FORMAT
37	00	DROM	ROUNDED PARAMETER
39	00	DROM	SAVING PARAMETERS NOT SUPPORTED
3A	00	DROM	MEDIUM NOT PRESENT
3F	00	DROM	ATAPI CD-ROM DRIVE OPERATING CONDITIONS HAVE CHANGED
3F	01	DROM	MICROCODE HAS BEEN CHANGED
3F	02	DROM	CHANGED OPERATING DEFINITION
3F	03	DROM	INQUIRY DATA HAS CHANGED
40	NN	DROM	DIAGNOSTIC FAILURE ON COMPONENT NN (80H-FFH)
44	00	DROM	INTERNAL ATAPI CD-ROM DRIVE FAILURE
4E	00	DROM	OVERLAPPED COMMANDS ATTEMPTED
53	00	DROM	MEDIA LOAD OR EJECT FAILED
53	02	DROM	MEDIUM REMOVAL PREVENTED
57	00	R	UNABLE TO RECOVER TABLE OF CONTENTS
5C	00	D O	STATUS CHANGE
5A	00	DROM	OPERATOR REQUEST OR STATE CHANGE INPUT (UNSPECIFIED)
5A	01	DROM	OPERATOR MEDIUM REMOVAL REQUEST
5B	01	DROM	THRESHOLD CONDITION MET
63	00	R	END OF USER AREA ENCOUNTERED ON THIS TRACK
64	00	R	ILLEGAL MODE FOR THIS TRACK
BF	00	R	LOSS OF STREAMING
80h XXh THROUGH FFh XX			Vendor-specific.
XXh 80h THROUGH XXh DDh			Vendor-specific QUALIFICATION OF STANDARD ASC.
ALL CODES NOT SHOWN ARE RESERVED.			

Table 125 - ASC and ASCQ Assignments

Table 126 - Recommended Sense Key, ASC and ASCQ for Request Sense Command Errors

Sense Key	ASC	ASCQ	Description of Error
05	20		INVALID COMMAND OPERATION CODE
05	24		INVALID FIELD IN COMMAND PACKET
06	28		NOT READY TO READY TRANSITION
06	29		POWER ON, RESET OR BUS DEVICE RESET OCCURRED

Preliminary Draft
for Review Only

Intentionally Left Blank

9.8.22 REZERO UNIT Command

The REZERO UNIT command requests that the ATAPI CD-ROM Drive set the Device to a specific state.

Table 127 - REZERO UNIT Command

Bit Byte	7	6	5	4	3	2	1	0
0	Operation code (01h)							
1	Reserved							
2	Reserved							
3	Reserved							
4	Reserved							
5	Reserved							
6	Reserved							
7	Reserved							
8	Reserved							
9	Reserved							
10	Reserved							
11	Reserved							

Table 128 - Recommended Sense Key, ASC and ASCQ for SEEK Command Errors

Sense Key	ASC	ASCQ	Description of Error
05	20		INVALID COMMAND OPERATION CODE
05	24		INVALID FIELD IN COMMAND PACKET
06	28		NOT READY TO READY TRANSITION
06	29		POWER ON, RESET OR BUS DEVICE RESET OCCURRED
02	04	00	LOGICAL UNIT NOT READY - CAUSE NOT REPORTABLE
02	04	01	LOGICAL UNIT NOT READY - IN PROGRESS OF BECOMING READY
02	04	02	LOGICAL UNIT NOT READY - INITIALIZING COMMAND REQUIRED
02	04	03	LOGICAL UNIT NOT READY - MANUAL INTERVENTION REQUIRED
02	06	00	NO REFERENCE POSITION FOUND (media may be upside down)
02	30	00	INCOMPATIBLE MEDIUM INSTALLED
02	30	01	CANNOT READ MEDIUM - UNKNOWN FORMAT
02	30	02	CANNOT READ MEDIUM - INCOMPATIBLE FORMAT
02	3A		MEDIUM NOT PRESENT
03	02		NO SEEK COMPLETE

Preliminary Draft
for Review Only

Intentionally Left Blank

9.8.23 *SEEK Command*

The SEEK command request that the Device seek to the specified logical block address. All Logical Block Addresses are valid targets for a seek operation, including a CD-DA audio sector. The content of the Sector at the specified LBA *shall not* affect the seek operation nor cause an error to be generated.

The SEEK Command will always be executed as an immediate command. The command will return completion stations as soon as the seek operation has been started.

Table 129 - *SEEK Command*

Bit Byte	7	6	5	4	3	2	1	0
0	Operation code (2Bh)							
1	Reserved							
2	Logical Block Address							
3								
4								
5								
6								
7	Reserved							
8	Reserved							
9	Reserved							
10	Reserved							
11	Reserved							

Table 130 - *Recommended Sense Key, ASC and ASCQ for Seek Command Errors*

Sense Key	ASC	ASCQ	Description of Error
05	20		INVALID COMMAND OPERATION CODE
05	24		INVALID FIELD IN COMMAND PACKET
06	28		NOT READY TO READY TRANSITION
06	29		POWER ON, RESET OR BUS DEVICE RESET OCCURRED
02	04	00	LOGICAL UNIT NOT READY - CAUSE NOT REPORTABLE
02	04	01	LOGICAL UNIT NOT READY - IN PROGRESS OF BECOMING READY
02	04	02	LOGICAL UNIT NOT READY - INITIALIZING COMMAND REQUIRED
02	04	03	LOGICAL UNIT NOT READY - MANUAL INTERVENTION REQUIRED
02	06	00	NO REFERENCE POSITION FOUND (media may be upside down)
02	30	00	INCOMPATIBLE MEDIUM INSTALLED
02	30	01	CANNOT READ MEDIUM - UNKNOWN FORMAT
02	30	02	CANNOT READ MEDIUM - INCOMPATIBLE FORMAT
02	3A		MEDIUM NOT PRESENT
03	02		NO SEEK COMPLETE
05	21		LOGICAL BLOCK ADDRESS OUT OF RANGE

Preliminary Draft
for Review Only

Intentionally Left Blank

9.8.24 SET CD-ROM SPEED Command

The SET CD-ROM SPEED command provides a means for the Host to set the spindle speed to be used while reading CD-ROM data. Note that the Play commands will not use the speed set by this command.

Table 131 - SET CD-ROM SPEED Command

Bit Byte	7	6	5	4	3	2	1	0
0	Operation code (BBh)							
1	Reserved							
2	(MSB) Drive Speed in Kbytes/Second (LSB)							
3								
4	Reserved							
5	Reserved							
6	Reserved							
7	Reserved							
8	Reserved							
9	Reserved							
10	Reserved							
11	Reserved							

The Drive Speed parameter contains the requested Data Rate the drive should use. The drive may choose to select the speed specified or any slower rate. A value of FFFFh will set the Drive Speed to the Maximum supported. Requesting a speed faster than the drive supports will not generate an error. The actual maximum speed supported is returned in the Capabilities Mode Sense page (See "9.8.5.4 CD-ROM Capabilities and Mechanical Status Page" on page 99.)

Table 132 - Recommended Sense Key, ASC and ASCQ for SET CD-ROM SPEED Command Errors

Sense Key	ASC	ASCQ	Description of Error
05	20		INVALID COMMAND OPERATION CODE
05	24		INVALID FIELD IN COMMAND PACKET
06	28		NOT READY TO READY TRANSITION
06	29		POWER ON, RESET OR BUS DEVICE RESET OCCURRED
02	04	00	LOGICAL UNIT NOT READY - CAUSE NOT REPORTABLE
02	04	01	LOGICAL UNIT NOT READY - IN PROGRESS OF BECOMING READY
02	04	02	LOGICAL UNIT NOT READY - INITIALIZING COMMAND REQUIRED
02	04	03	LOGICAL UNIT NOT READY - MANUAL INTERVENTION REQUIRED
02	06	00	NO REFERENCE POSITION FOUND (media may be upside down)
02	30	00	INCOMPATIBLE MEDIUM INSTALLED
02	30	01	CANNOT READ MEDIUM - UNKNOWN FORMAT
02	30	02	CANNOT READ MEDIUM - INCOMPATIBLE FORMAT
02	3A		MEDIUM NOT PRESENT

Preliminary Draft
for Review Only

Intentionally Left Blank

9.8.25 STOP PLAY / SCAN CD-ROM Command

The STOP PLAY/ SCAN CD-ROM Command stops playback of CD-ROM audio commands.

Table 133 - STOP PLAY / SCAN CD-ROM Command

Bit Byte	7	6	5	4	3	2	1	0
0	Operation code (4Eh)							
1	Reserved							
2	Reserved							
3	Reserved							
4	Reserved							
5	Reserved							
6	Reserved							
7	Reserved							
8	Reserved							
9	Reserved							
10	Reserved							
11	Reserved							

Table 134 - Recommended Sense Key, ASC and ASCQ for STOP PLAY CD-ROM Command Errors

Sense Key	ASC	ASCQ	Description of Error
05	20		INVALID COMMAND OPERATION CODE
05	24		INVALID FIELD IN COMMAND PACKET
06	28		NOT READY TO READY TRANSITION
06	29		POWER ON, RESET OR BUS DEVICE RESET OCCURRED
02	04	00	LOGICAL UNIT NOT READY - CAUSE NOT REPORTABLE
02	04	01	LOGICAL UNIT NOT READY - IN PROGRESS OF BECOMING READY
02	04	02	LOGICAL UNIT NOT READY - INITIALIZING COMMAND REQUIRED
02	04	03	LOGICAL UNIT NOT READY - MANUAL INTERVENTION REQUIRED
02	06	00	NO REFERENCE POSITION FOUND (media may be upside down)
02	30	00	INCOMPATIBLE MEDIUM INSTALLED
02	30	01	CANNOT READ MEDIUM - UNKNOWN FORMAT
02	30	02	CANNOT READ MEDIUM - INCOMPATIBLE FORMAT
02	3A		MEDIUM NOT PRESENT
0B	BA		PLAY XA OPERATION ABORTED

Issuing a Stop Play / Scan command while the drive is scanning *shall* result in continuation of the play command. Issuing a Stop Play / Scan command while the drive is paused *shall* stop the play command

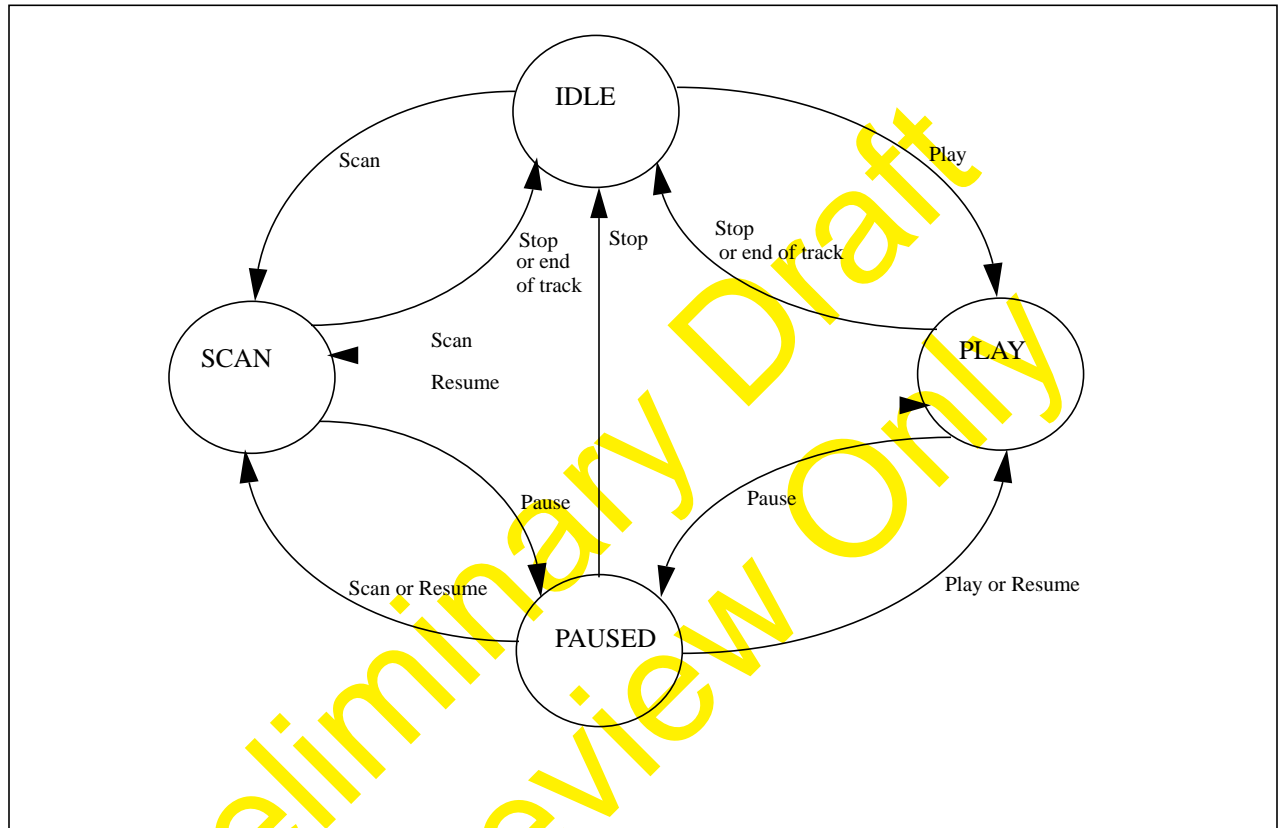

Figure 17 - Stop Play/Play Audio/Audio Scan/Pause/Resume Sequencing

9.8.26 START/STOP UNIT Command

The START/STOP UNIT command requests that the ATAPI CD-ROM Drive enable or disable media access operations.

Table 135 - START/STOP UNIT Command

Bit Byte	7	6	5	4	3	2	1	0
0	Operation code (1Bh)							
1	Reserved							Immed
2	Reserved							
3	Reserved							
4	Reserved						LoEj	Start
5	Reserved							
6	Reserved							
7	Reserved							
8	Reserved							
9	Reserved							
10	Reserved							
11	Reserved							

An immediate (Immed) bit of one indicates that status *shall* be returned as soon as the Command Packet has been validated. An Immed bit of zero indicates that status *shall* be returned after the operation is completed.

A start bit of one requests the Device be made ready for use. A start bit of zero requests that the Device be stopped (media cannot be accessed by the Host Computer).

Table 136 - Start/Stop and Eject Operations

LoEj	Start	Operation to be Performed
0	0	Stop the Disc
0	1	Start the Disc and read the TOC
1	0	Eject the Disc if possible (See "Table 72 - Actions for Lock / Unlock / Eject" on page 116)
1	1	Load the Disc (Close Tray)

Any attempt to Eject or Load a Disc when the Drive does not support that capability *shall* result in an error condition being reported to the Host (Sense key 05 ILLEGAL REQUEST, Sense Code 24 INVALID FIELD IN COMMAND PACKET.)

A load eject (LoEj) bit of zero requests that no action be taken regarding loading or ejecting the medium. A LoEj bit of one requests that the medium be unloaded if the start bit is zero. A LoEj bit of one requests that the medium be loaded if the start bit is one.

Table 137 - Actions for Eject/Load Disc

Operation	Locked / Unlocked	If Drive Not Ready (No Media)	If Drive Ready (Media Present)
Eject	Unlocked	No Error and Tray is opened	No Error: Media Ejects
	Locked	Error: 02 Not ready, 53 Media Removal Prevented	Error: 02 Not ready, 53 Media Removal Prevented
Manual Eject	Unlocked	Tray opens (If tray exists)	Media is Ejected
	Locked	No operation occurs	No operation, Media stays locked in drive

Table 138 - Recommended Sense Key, ASC and ASCQ for SEEK Command Errors

Sense Key	ASC	ASCQ	Description of Error
05	20		INVALID COMMAND OPERATION CODE
05	24		INVALID FIELD IN COMMAND PACKET
06	28		NOT READY TO READY TRANSITION
06	29		POWER ON, RESET OR BUS DEVICE RESET OCCURRED
02	04	00	LOGICAL UNIT NOT READY - CAUSE NOT REPORTABLE
02	04	01	LOGICAL UNIT NOT READY - IN PROGRESS OF BECOMING READY
02	04	02	LOGICAL UNIT NOT READY - INITIALIZING COMMAND REQUIRED
02	04	03	LOGICAL UNIT NOT READY - MANUAL INTERVENTION REQUIRED
02	06	00	NO REFERENCE POSITION FOUND (media may be upside down)
02	30	00	INCOMPATIBLE MEDIUM INSTALLED
02	30	01	CANNOT READ MEDIUM - UNKNOWN FORMAT
02	30	02	CANNOT READ MEDIUM - INCOMPATIBLE FORMAT
02	3A		MEDIUM NOT PRESENT
02	53	02	MEDIA REMOVAL PREVENTED
04	B6		MEDIA LOAD MECHNISM FAILED

9.8.27 TEST UNIT READY Command

The TEST UNIT READY command provides a means to check if the Device is ready. This is not a request for a self-test. If the Device would accept an appropriate medium-access command without returning CHECK CONDITION status, this command *shall* return a GOOD status. If the Device cannot become operational or is in a state such that an Host Computer action (e.g. START UNIT command) is required to make the unit ready, the ATAPI CD-ROM Drive *shall* return CHECK CONDITION status with a sense key of NOT READY.

Table 139 - Test Unit Ready Command

Bit Byte	7	6	5	4	3	2	1	0
0	Operation code (00h)							
1	Reserved							
2	Reserved							
3	Reserved							
4	Reserved							
5	Reserved							
6	Reserved							
7	Reserved							
8	Reserved							
9	Reserved							
10	Reserved							
11	Reserved							

9.8.27.1 Using the TEST UNIT READY Command

The TEST UNIT READY command is useful in that it allows a Host Computer to poll a Device until it is ready without the need to allocate space for returned data. It is especially useful to check cartridge status. ATAPI CD-ROM Drives are expected to respond promptly to indicate the current status of the device.

Table 140 - Recommended Sense Key, ASC and ASCQ for MODE SELECT Command Errors

Sense Key	ASC	ASCQ	Description of Error
00	00	00	NO ADDITIONAL SENSE INFORMATION
05	20		INVALID COMMAND OPERATION CODE
05	24		INVALID FIELD IN COMMAND PACKET
02	04	00	LOGICAL UNIT NOT READY - CAUSE NOT REPORTABLE
02	04	01	LOGICAL UNIT NOT READY - IN PROGRESS OF BECOMING READY
02	04	02	LOGICAL UNIT NOT READY - INITIALIZING COMMAND REQUIRED
02	04	03	LOGICAL UNIT NOT READY - MANUAL INTERVENTION REQUIRED
02	3A		MEDIUM NOT PRESENT

Preliminary Draft
for Review Only

Intentionally Left Blank

10.0 Physical Interface

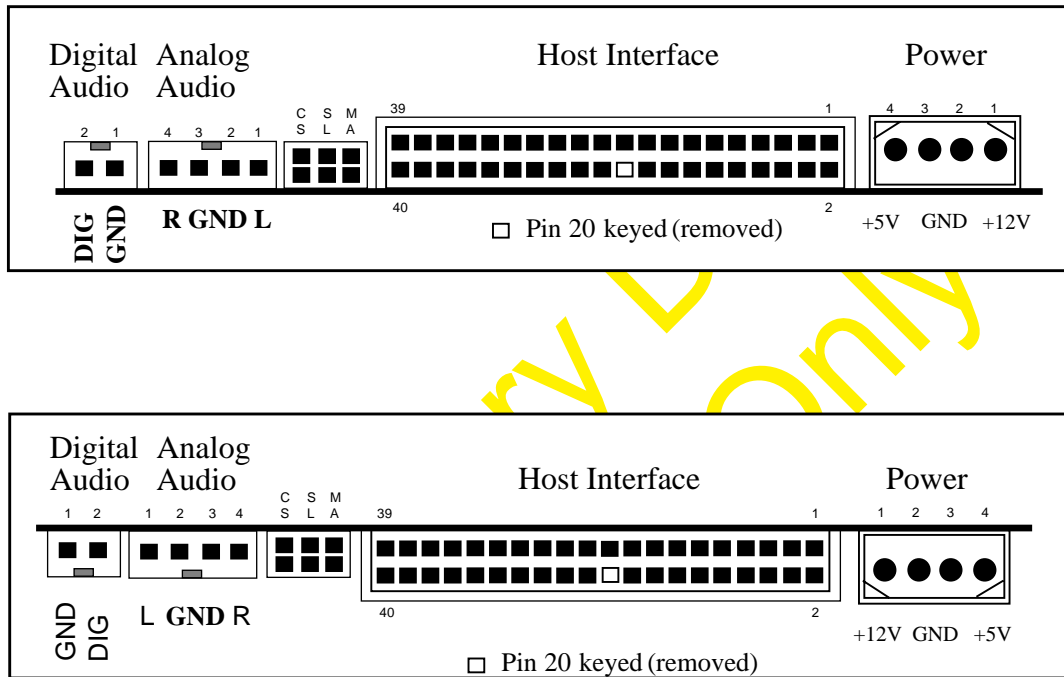

Figure 18 - CD-ROM Connectors (Rear View)

10.1 CD-ROM Digital Audio Connector (Optional)

The CD-ROM Digital Audio Connector is an optional two-conductor shroud keyed header (Molex 70553 “G” or equivalent) which can be used to send audio to the host in a digital serial format. The pin assignments are shown in "Figure 18 - CD-ROM Connectors (Rear View)". The logic levels on this connector are standard CMOS and *shall* not exceed +5% of the 5v supply. Recommended part numbers for the mating connector to 18 AWG cable are shown, but equivalent parts may be used.

Mating Connectors: Molex 70066 “C(No Latch)” or “G(Latch)”, 70400 “C” or “G” and 70430 “C” or “G” or equivalent.

The serial format of the audio data is defined in EIAJ (Electronic Industry Association of Japan) document IEC-958. IEC-958 has two parts. One is for professional use that is similar to the AES/EBU (Audio Engineering Society / European Broadcast Union). The other part is for consumer use and is the same as the Sony/Philips Digital Signal format. When referring to EIAJ, specify which part is supported.

10.2 CD-ROM Analog Audio Connector (Optional)

The CD-ROM Analog Audio Connector is an optional four-conductor shroud keyed header (Molex 70553 “G” or equivalent) which can be used to send audio to the host in an analog format. The pin assignments are shown in "Figure 18 - CD-ROM Connectors (Rear View)". The analog voltage levels on this connector *shall not* exceed 1.0V RMS. Recommended part numbers for the mating connector to 18 AWG cable are shown, but equivalent parts may be used.

Mating Connectors: Molex 70066 “C(No Latch)” or “G(Latch)”, 70400 “C” or “G” and 70430 “C” or “G” or equivalent.

10.3 Device Configuration Jumper (Optional)

The device configuration jumper is a 6-pin, unshrouded header (Molex 70203 or equivalent) as shown in "Figure 18 - CD-ROM Connectors (Rear View)" with three marked positions (BY, SL, and MA). When a shorting jumper is placed in the "BY" (Bypass CSEL) position the device *shall* use the "MA" (Master) or "SL" (Slave) jumper positions to configure the device. When the "BY" jumper is removed and placed such that both "SL" and "MA" are jumpered, the device *shall* use the host interface signal CSEL to configure the device. The device configuration jumpers *shall* be accessible from the rear of the drive.

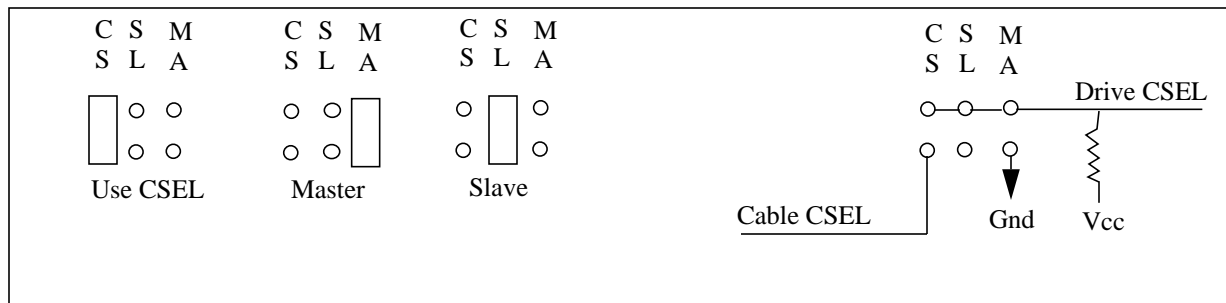

Figure 19 - Device Configuration Jumper

10.4 Host IDE Interface Connector

The I/O connector is a 40-pin connector as shown in Figure 4 (ATA specification), with pin assignments as shown in Table 4 (ATA specification). The connector should be keyed to prevent the possibility of installing it upside down. A key is provided by the removal of pin 20. The corresponding pin on the cable connector should be plugged.

The pin locations are governed by the cable plug, not the receptacle. The way in which the receptacle is mounted on the printed circuit board affects the pin positions, and pin 1 should remain in the same relative position. This means the pin numbers of the receptacle may not reflect the conductor number of the plug. The header receptacle is not polarized, and all the signals are relative to pin 20, which is keyed.

By using the plug positions as primary, a straight cable can connect drives. As shown in Figure 4 (ATA specification, conductor 1 on pin 1 of the plug has to be in the same relative position no matter what the receptacle numbering looks like. If receptacle numbering was followed, the cable would have to twist 180 degrees between a drive with top-mounted receptacles, and a drive with bottom-mounted receptacles.

10.5 Power Connector

The power connector is a four-conductor male plug. The pin assignments are shown in "Figure 18 - CD-ROM Connectors (Rear View)". Recommended part numbers for the mating connector to 28 AWG cable are shown below, but equivalent parts may be used.

- Connector (4-pin): AMP 1-480424-0 or equivalent.
- Contacts (loose piece): AMP 60619-4 or equivalent.
- Contacts (strip): AMP 61117-4 or equivalent.

Annex A Vendor Identification

This annex contains the list of vendor identifications as of the date of this document. The purpose of this list is to help avoid redundant usage of vendor identifications. Task Group X3T9.2 of Accredited Standards Committee X3 maintains an informal list of vendor identifications currently in use. Please contact the chairman of X3T9.2 prior to using a new vendor identification to avoid conflicts.

Table 141 - Vendor Identification List

ID	Organization
3M	3M Company
ADAPTEC	Adaptec
ACL	Automated Cartridge Librarys, Inc.
ADSI	Adaptive Data Systems, Inc. (a Western Digital subsidiary)
AMCODYNE	Amcodyne
ANAMATIC	Anamartic Limited (England)
ANCOT	ANCOT Corp.
ANRITSU	Anritsu Corporation
APPLE	Apple Computer, Inc.
ARCHIVE	Archive
ASACA	ASACA Corporation
ASPEN	Aspen Peripherals
AST	AST Research
ASTK	Alcatel STK A/S
AT&T	AT&T
ATARI	Atari Corporation
ATTO	ATTO Technology Inc.
ATX	Alphatronix
AVR	Advanced Vision Research
BALLARD	Ballard Synergy Corp.
BERGSWD	Berg Software Design
BEZIER	Bezier Systems, Inc.
BULL	Bull Peripherals Corp.
CalComp	CalComp, A Lockheed Company
CALIPER	Caliper (California Peripheral Corp.)
CAST	Advanced Storage Tech
CDC	Control Data or MPI
CDP	Columbia Data Products
CHEROKEE	Cherokee Data Systems
CIE&YED	YE Data, C.Itoh Electric Corp.
CHINON	Chinon
CIPHER	Cipher Data Products
Ciprico	Ciprico, Inc.
CMD	CMD Technology
CNGR SFW	Congruent Software, Inc.
COGITO	Cogito
COMPORT	Comport Corp.
COMPSIG	Computer Signal Corporation
CONNER	Conner Peripherals
CREO	CREO Products Inc.

Table 141 - Vendor Identification List

ID	Organization
CROSFELD	Crosfield Electronics
CSM, INC	Computer SM, Inc.
CYGNET	Cygnnet Systems, Inc.
DATABOOK	Databook, Inc.
DATACOPY	Datacopy Corp.
DATAPT	Datapoint Corp.
DEC	Digital Equipment
DELPHI	Delphi Data Div. of Sparks Industries, Inc.
DENON	Denon/Nippon Columbia
DEST	DEST Corp.
DGC	Data General Corp.
DIGIDATA	Digi-Data Corporation
DILOG	Distributed Logic Corp.
DISC	Document Imaging Systems Corp.
DPT	Distributed Processing Technology
DSM	Deterner Steuerungs- und Maschinenbau GmbH & Co.
DTC QUME	Data Technology Qume
DXIMAGIN	DX Imaging
EMULEX	Emulex
EPSON	Epson
EXABYTE	Exabyte Corp.
FILENET	FileNet Corp.
FUJI	Fuji Electric Co., Ltd. (Japan)
FUJITSU	Fujitsu
FUTURED	Future Domain Corp.
GEN_DYN	General Dynamics
GIGATAPE	GIGATAPE GmbH
GIGATRND	GigaTrend Incorporated
Goidelic	Goidelic Precision, Inc.
GOULD	Gould
HITACHI	Hitachi America Ltd or Nissei Sangyo America Ltd
HONEYWEL	Honeywell Inc.
HP	Hewlett Packard
IBM	International Business Machines
ICL	ICL
IDE	International Data Engineering, Inc.
IGR	Intergraph Corp.
IMPLTD	Integrated Micro Products Ltd.
IMPRIMIS	Imprimis Technology Inc.
IOC	I/O Concepts, Inc.
INSITE	Insite Peripherals
IOMEGA	Iomega
ISI	Information Storage inc.
ITC	International Tapetronics Corporation
JVC	JVC Information Products Co.
KENNEDY	Kennedy Company
KODAK	Eastman Kodak

Table 141 - Vendor Identification List

ID	Organization
KONAN	Konan
KONICA	Konica Japan
LAPINE	Lapine Technology
LASERDRV	LaserDrive Limited
LASERGR	Lasergraphics, Inc.
LMS	Laser Magnetic Storage International Company
MATSHITA	Matsushita
MAXTOR	Maxtor Corp.
MaxOptix	Maxoptix Corp.
MDI	Micro Design International, Inc.
MELA	Mitsubishi Electronics America
MELCO	Mitsubishi Electric (Japan)
MEMREL	Memrel Corporation
MEMTECH	MemTech Technology
MICROBTX	Microbotics Inc.
MICROP	Micropolis
MICROTEK	Microtek Storage Corp
MINSCRIB	Miniscribe
MITSUMI	MITSUMI Electric Co., Ltd.
MOTOROLA	Motorola
MST	Morning Star Technologies, Inc.
NAI	North Atlantic Industries
NatInst	National Instruments
NatSemi	National Semiconductor Corp.
NCL	NCL America
NCR	NCR Corporation
NEC	NEC
NISCA	NISCA Inc.
OCE	Oce Graphics
OMI	Optical Media International
OMNIS	OMNIS Company (FRANCE)
OPTIMEM	Cipher/Optimem
OPTOTECH	Optotech
ORCA	Orca Technology
OSI	Optical Storage International
OTL	OTL Engineering
PERTEC	Pertec Peripherals Corporation
PFTI	Performance Technology Inc.
PIONEER	Pioneer Electronic Corp.
PRAIRIE	PrairieTek
PRESOFT	PreSoft Architects
PRESTON	Preston Scientific
PRIAM	Priam
PRIMAGFX	Primagraphics Ltd
PTI	Peripheral Technology Inc.
QUALSTAR	Qualstar
QUANTEL	Quantel Ltd.

Table 141 - Vendor Identification List

ID	Organization
QUANTUM	Quantum Corp.
R-BYTE	R-Byte Inc.
RADSTONE	Radstone Technology
RGI	Raster Graphics, Inc.
RICOH	Ricoh
RODIME	Rodime
RTI	Reference Technology
SANKYO	Sankyo Seiki
SANYO	SANYO Electric Co., Ltd.
SCREEN	Dainippon Screen Mfg. Co., Ltd.
SEAGATE	Seagate
SEQUOIA	Sequoia Advanced Technologies, Inc.
Shinko	Shinko Electric Co., Ltd.
SIEMENS	Siemens
SII	Seiko Instruments Inc.
SMS	Scientific Micro Systems/OMTI
SONIC	Sonic Solutions
SONY	Sony Corporation Japan
SPECTRA	Spectra Logic, a Division of Western Automation Labs, Inc.
SPERRY	Sperry (now Unisys Corp.)
STK	Storage Technology Corporation
SUMITOMO	Sumitomo Electric Industries, Ltd.
SUN	Sun Microsystems, Inc.
SNYSIDE	Sunnyside Computing Inc.
SyQuest	SyQuest Technology, Inc.
SYSGEN	Sysgen
T-MITTON	Transmitton England
TALLGRAS	Tallgrass Technologies
TALARIS	Talaris Systems, Inc.
TANDBERG	Tandberg Data A/S
TANDON	Tandon
TEAC	TEAC Japan
TECOLOTE	Techolote Designs
Tek	Tektronix
TI-DSG	Texas Instruments
TOSHIBA	Toshiba Japan
ULTRA	UltraStor Corporation
UNISYS	Unisys
USDC	US Design Corp.
VERBATIM	Verbatim Corporation
VRC	Vermont Research Corp.
WangDAT	WangDAT
WANGTEK	Wangtek
WEARNES	Wearnes Technology Corporation
WDIGTL	Western Digital
XEBEC	Xebec Corporation

Annex B CD-ROM XA

B.1 ATAPI XA Packet Commands for CD-ROM Devices

B.1.1 PLAY CD-ROM XA Command

Table 142 - PLAY CD-ROM XA (12) Command

Bit Byte	7	6	5	4	3	2	1	0
0	Operation code (BDh)							
1	Reserved							
2	Starting Logical Block Address							
3								
4								
5								
6								
7								
8								
9								
10	File Number							
11	Reserved							

Since Mode2 XA file system can retrieve data in real-time manner, it is called a “PLAY” when retrieving the real-time file system. The real-time file has a real time bit in the subheader / submode field of each of the sectors. (See CD-ROM XA Chap II, 4.3 System Description)

PLAY XA sends 2340 Bytes/Sector data (Header (4) + Subheader (9) + UserData (2324 or 2048) + Spare (4) or EDC&ECC (280)) or 12 bytes of data (Header + Subheader (8)) in real-time manner to the system, in the following manner:

1. If the sector has the specified file number, goto (2).
2. The sector has the specified channel number (by channel mask), goto (3).
3. If the sector has empty sector type (not Audio, not Video, not Data), goto (6), otherwise goto (4).
4. If the sector has a data type of Video or Data, goto (7), otherwise goto (5).
5. If the sector has Audio data type and it is linked to the appropriate ADPCM decoder, the sector will be decoded automatically. Goto (6), otherwise goto (7).
6. Drive sends 12 bytes (header (4) + SubHeader (8)) to the system.

Drive sends 2340 bytes (Header (4) + SubHeader (8) + UserData (2324 or 2048) + Spare (4) or EDC&ECC (280))

Table 143 - Recommended Sense Key, ASC and ASCQ for PLAY CD-ROM XA (12) Command Errors

Sense Key	ASC	ASCQ	Description of Error
05	20		INVALID COMMAND OPERATION CODE
05	24		INVALID FIELD IN COMMAND PACKET
06	28		NOT READY TO READY TRANSITION
06	29		POWER ON, RESET OR BUS DEVICE RESET OCCURRED
02	04	00	LOGICAL UNIT NOT READY - CAUSE NOT REPORTABLE
02	04	01	LOGICAL UNIT NOT READY - IN PROGRESS OF BECOMING READY
02	04	02	LOGICAL UNIT NOT READY - INITIALIZING COMMAND REQUIRED
02	04	03	LOGICAL UNIT NOT READY - MANUAL INTERVENTION REQUIRED
02	06	00	NO REFERENCE POSITION FOUND (media may be upside down)
02	30	00	INCOMPATIBLE MEDIUM INSTALLED
02	30	01	CANNOT READ MEDIUM - UNKNOWN FORMAT
02	30	02	CANNOT READ MEDIUM - INCOMPATIBLE FORMAT
02	3A		MEDIUM NOT PRESENT
03	02		NO SEEK COMPLETE
05	21		LOGICAL BLOCK ADDRESS OUT OF RANGE
05	54		ILLEGAL MODE FOR THIS TRACK
03	11	05	L-EC UNCORRECTABLE ERROR
03	11	06	CIRC UNRECOVERED ERROR
05	BF	00	BUFFER OVERFLOW ^a

a. If the PLAY CD-ROM XA Command fails to transfer a block of data to the Host in 13.3 Ms (1/75 s), the ATAPI CD-ROM *shall* terminate the PLAY CD-ROM XA Command with CHECK CONDITION, the sense key *shall* be set to ILLEGAL REQUEST, and the additional sense code set to BUFFER OVERFLOW.

B.1.2 SEND CD-ROM XA DATA (12) Command

The SEND CD-ROM XA DATA Command sends XA data from the Host to the CD-ROM drive. This command is initially intended to provide the host with the ability to play audio through the CD-ROMs stereo ADPCM decoder thereby eliminating the need for separate sound boards in CD-ROM based multi-medi systems. Future extensions may include the ability for the Host to send video to ATAPI CDI-ROM drives in XA format.

Table 144 - SEND CD-ROM XA DATA (12) Command

Bit Byte	7	6	5	4	3	2	1	0
0	Operation code (BCh)							
1	Reserved							
2	Reserved							
3	Reserved							
4	Reserved							
5	Reserved							
6	Reserved							
7	Reserved							
8	Reserved							
9	Reserved							
10	Reserved							
11	Reserved							

The user can play back ADPCM data from the Host to the ADPCM Decoder in the following manner:

1. Issue XA Control Mode Page Format, setting the Audio Channel Number to 0x80.
2. If ADPCM Decoder Status/ADPCM Buffer Status is one, issue the SEND ADPCM DATA Command.
3. When the interrupt requests "Data from Host to Drive," send the data to the drive.
4. Goto (2).

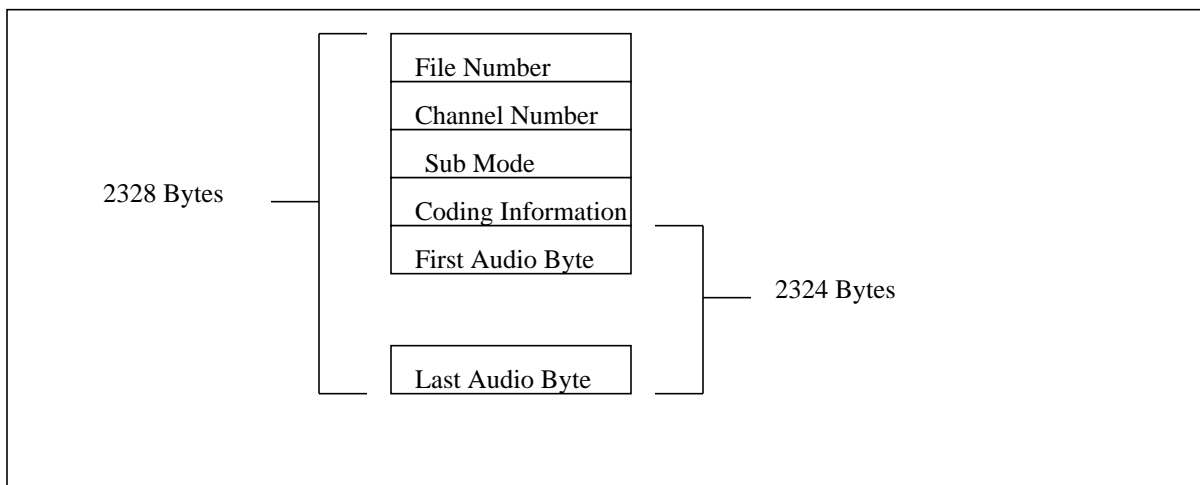

File format for Send Audio is identical to XA data with the addition of a file and channel number to the header information. EOF in the header is end of file for all channels in this file, I.E. the end of this command.

Table 145 - Recommended Sense Key, ASC and ASCQ for SEND CD-ROM XA ADPCM DATA Command Errors

Sense Key	ASC	ASCQ	Description of Error
05	20		INVALID COMMAND OPERATION CODE
05	24		INVALID FIELD IN COMMAND PACKET
06	28		NOT READY TO READY TRANSITION
06	29		POWER ON, RESET OR BUS DEVICE RESET OCCURRED
02	04	00	LOGICAL UNIT NOT READY - CAUSE NOT REPORTABLE
02	04	01	LOGICAL UNIT NOT READY - IN PROGRESS OF BECOMING READY
02	04	02	LOGICAL UNIT NOT READY - INITIALIZING COMMAND REQUIRED
02	04	03	LOGICAL UNIT NOT READY - MANUAL INTERVENTION REQUIRED
02	BB		ADPCM DATA BUFFER NOT READY

Preliminary
for Review Only

Annex C Connectors

C.1 Connectors / Jumpers

70553 Series

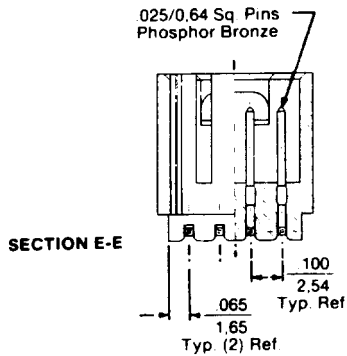
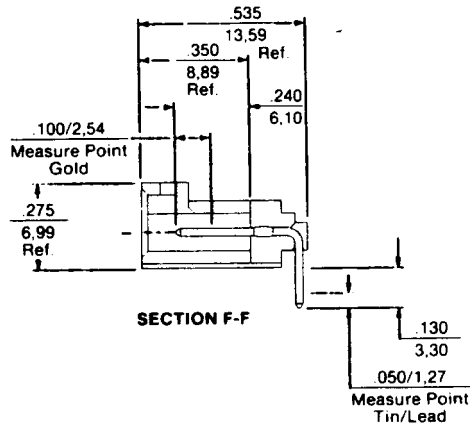
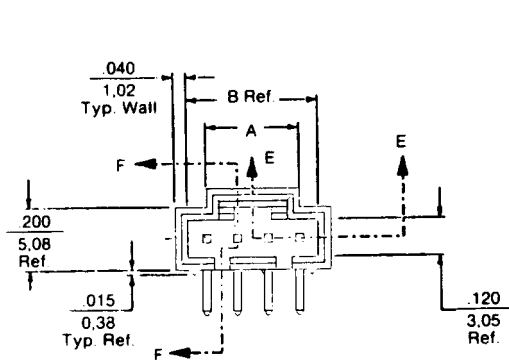
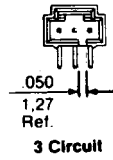
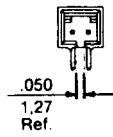
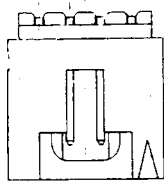
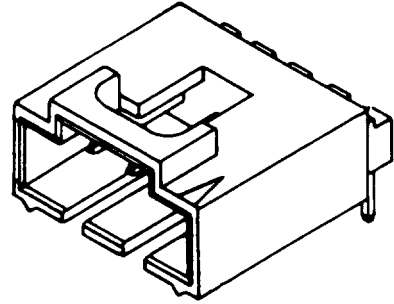

Recommended P.C. Board Hole Layout

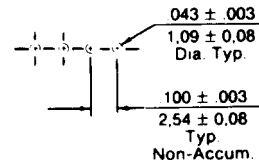

Dimensions

Circuits	Dim. A	Dim. B
2	100 2.54	.210 5.33
3	200 5.08	.320 8.13
4	300 7.62	.420 10.67

70066 Series "C" Version,

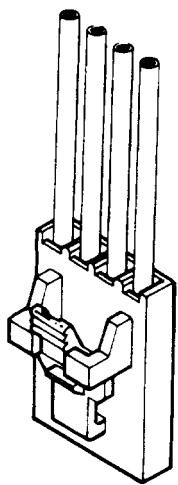
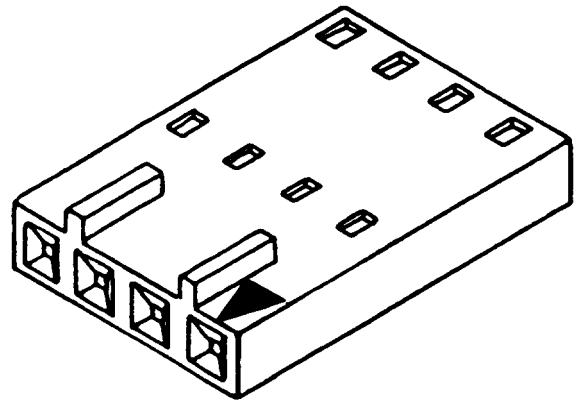

70066-G

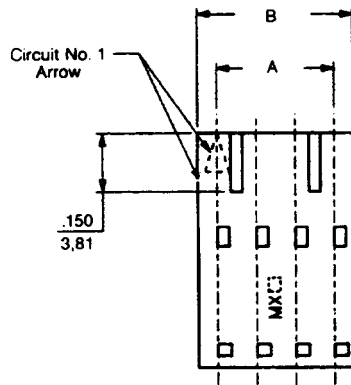
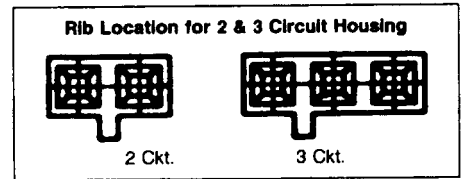
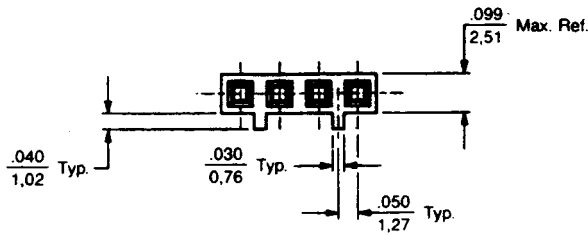

Section C-C

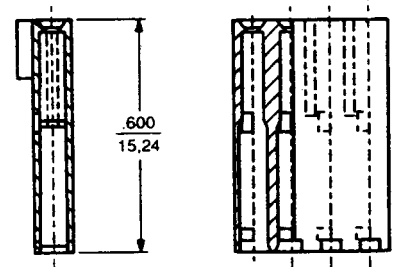

Dimensions

Circuits	Dim. A	Dim. B
2	.100 2,54	.199 5,05
3	.200 5,08	.299 7,59
4	.300 7,62	.399 10,13

70203 Series

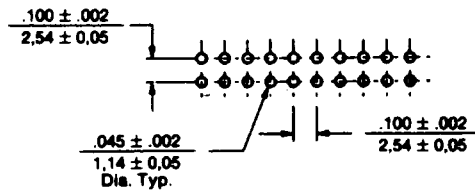
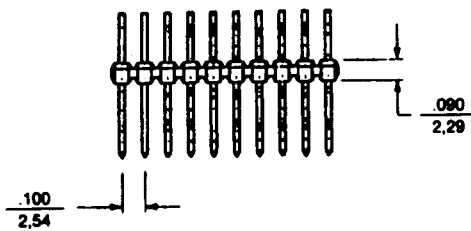
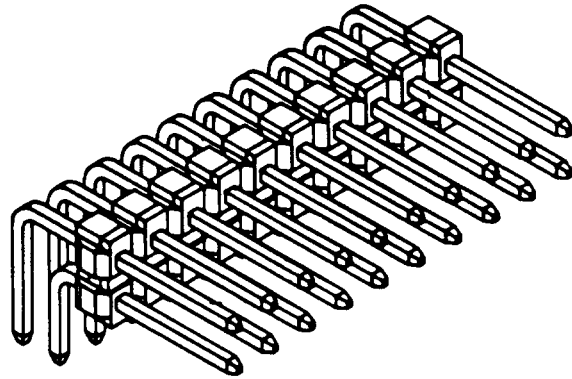

Recommended P.C. Board Hole Layout

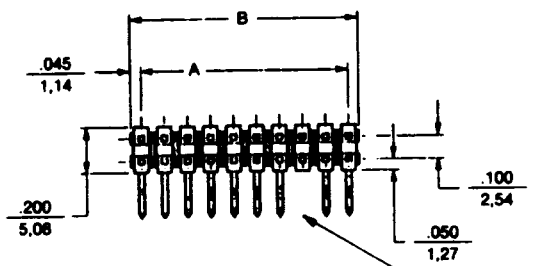

Selective Voids Available

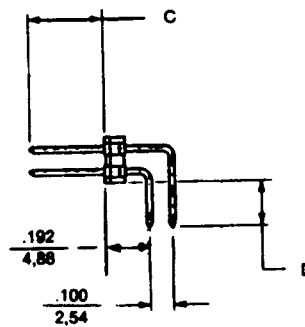

In the Far East, this product has different Eng. Nos. and Order No Contact factory for sales drawings on 70294-XXX.

Dimensions

Circuits	Dim. A*	Dim. B*	Circuits	Dim. A*	Dim. B*
4	.100 2,54	.190 4,83	6	.200 5,08	.290 7,37

*For circuit sizes 8 through 80 add .100" or 2,54mm for each additional pin position

**Preliminary Draft
for Review Only**